

Eco^{truxure}[™]
Innovation At Every Level



SeT Series

SM AirSeT

Catalog 2024
Fully air insulated switchgear up to 24 kV

Pure air technology for a greener future



se.com/smairset

Life Is 

Schneider
Electric

General contents

SM AirSeT



Overview	13
Range description	26
Function/module description	46
Components and accessories	56
Installation and connection	98



Connectivity and Innovative technologies for greater sustainability and efficiency

Powered by air and digital

SM AirSeT is a range of SF₆-free modular air-insulated switchgear for MV secondary distribution installations in commercial and industrial buildings and utilities sectors.

Sustainability, let's clear the Air

Today, everyone wants to decarbonize, but increasing electricity demand creates a conflict of how.... until now!

SM AirSeT answers that need by enabling the change from SF₆ to a sustainable technology that combines pure air for insulation and vacuum technology for arc interruption. Our innovative arrangement with Shunt Vacuum Interruption (SVI)[™] is used for breaking without use of alternative gases, and producing no toxic by-products.

We offer the same performance, footprint and functionality as our previous generation switchgear, but with the enhanced sustainability available.



Natively Digital

The standard SM AirSeT takes advantage of advancements in digitization to be digitally connected by default.

The QR code on every product unlocks the digital environment with a library of apps and services including your Digital Logbook, an easy to use digital tool to store and share all of your essential project information from design until end of life.

Seamlessly integrated smart sensors gather data about the condition of components and installation environment. It can be easily shared to improve all aspects of the product life. Starting with periodic maintenance apps today, or planning ahead for predictive maintenance. Connectivity is scalable to fit the needs of your applications and future plans.

* Scalable with additional sensors using Connectivity Tiers such as Active Plus

[Watch SF₆-free video playlist](#)



Innovation is in the Air

SM AirSeT brings sustainable innovation to support the transition to greener energy systems and installations. It combines pure air for insulation and vacuum technology for breaking in an ingenious arrangement called Shunt Vacuum Interruption (SVI)™.

Why SF₆-free?

Today, distribution networks and installations commonly rely on SF₆ gas. It has outstanding dielectric properties, which allows for high performance and compact equipment. This is critical in many buildings and applications where space is scarce. The downside is that it is a potent greenhouse gas with Global Warming Potential 24 300 higher than that of CO₂, and produces toxic by-products in the process of breaking. As such it is subject to strict regulation and must be recycled properly to avoid negative impact on the environment. Regulators are increasingly considering the adoption of new measures to limit the use of SF₆.

Pure air as the ultimate choice

Adopting pure air switchgear is not only better for the environment but also helps improve health and safety as pure air is naturally sustainable. It reduces the switchgear's carbon footprint across its full lifecycle - from manufacturing to end of life - by eliminating the need for SF₆ or alternative gas and avoiding the end-of-life recapture, recycling.

No compromise on benefits

The ingenious design retains the benefits valued by customers in former SF₆ equipment: compact physical footprint, 3-position switch, transformer protection via switch-fuse unit - all important considerations to avoid changes to installations and working practices.

Transparent for the future

Pure air is transparent and gives peace-of-mind, because it helps avoid the risk of future regulations.



Green Premium™

The Green Premium program stands for our commitment to deliver customer valued sustainable performance. It has been upgraded with recognized environmental claims and extended to cover all offers including Products, Services and Solutions.



More than 75 % of our product sales offer superior transparency on the material content, regulatory information and environmental impact of our products:

- RoHS compliance
- REACH substance information
- Industry leading # of PEP's*
- Circularity instructions



Discover what we mean by green
[Check your products!](#)

An industry leading portfolio of offers delivering sustainable value

CO₂ and P&L impact through... Resource Performance

Green Premium brings improved resource efficiency throughout an asset's lifecycle. This includes efficient use of energy and natural resources, along with the minimization of CO₂ emissions.

Cost of ownership optimization through... Circular Performance

We are helping our customers optimize the total cost of ownership of their assets. To do this, we provide IoT-enabled solutions, as well as upgrade, repair, retrofit, and remanufacture services.

Peace of mind through... Well-being Performance

Green Premium products are RoHS and REACH compliant. We are going beyond regulatory compliance with step-by-step substitution of certain materials and substances in our products.

Improved sales through... Differentiation

Green Premium delivers strong value propositions through third-party labels and services. By collaborating with third-party organizations we can support our customers in meeting their sustainability goals such as green building certifications.

*PEP: Product Environmental Profile (i.e. Environmental Product Declaration)

Sustainability without compromise

Innovation is in the Air

Pure air technology delivers unprecedented transparency for operations, maintenance and end-of-life.



Durability

Lifespan is extended to 40 years thanks to:

- Innovative Shunt Vacuum Interruption (SVI)TM combining the proven and robust technologies of pressurized air insulation and vacuum breaking
- Improved mechanical endurance delivered by high-tech mechanisms (CompoDrive)

Upgradeability

- Simple on-site integration of motorization with our plug-and-play system
- Supplementary functional units with easy extensibility, due to footprint identical to former technology. No civil works adaptation required
- EcoStruxure-ready: sensors TH110, CL110, LPVT, LPCT, VIP, arc detection

Resource Performance

- SM AirSeT load break switch is mounted in a sealed tank filled with air. The tank also contains a vacuum bottle
- No toxic or alternative gases are used
- Sensors integrated for condition-based maintenance: fewer site visits

Circular Performance

- Easier end-of-life management: No toxic by-products are produced in breaking. There is no need for recovery or recycling of air. It can be released into the atmosphere
- Vacuum interrupters avoid risks of leakage of the toxic by-products of arc-breaking: safer for operation and the environment















SM AirSeT provides LEEDTM credits

- Building Product Disclosure and Optimization
- Advanced Energy Metering

Scalable to your needs

Native and scalable to your needs

IoT connected SM AirSeT switchgear is a foundational element of EcoStruxure, Schneider Electric IoT-enabled, open, and interoperable system architecture. Connectivity by default means that customers benefit from greater visibility of their facilities and have more control over operational health.

SM AirSeT	SM AirSeT Active	SM AirSeT Active Plus
Enriched Experience <ul style="list-style-type: none"> • Thermal monitoring • Digital Logbook for maintenance 	Massive Connectivity <ul style="list-style-type: none"> • 24/7 connected condition monitoring of your switchgear with local, remote and cloud based connectivity for advanced services. 	Comprehensive Monitoring & Control <ul style="list-style-type: none"> • Decision and Control capabilities from Edge layer for all devices. • Comprehensive condition monitoring solution from local, nearby, or remote.
 Environmental Monitoring (optional)	 Condition Monitoring alarms  EcoStruxure Service Plan  Edge & cloud connectivity  Environmental Monitoring  Remote terminal unit (optional)  HMI (optional)	 Partial discharge monitoring  Condition Monitoring alarms  EcoStruxure Service Plan  Edge & cloud connectivity  Environmental Monitoring  Remote terminal unit (optional)  HMI (optional)

Digital Tools

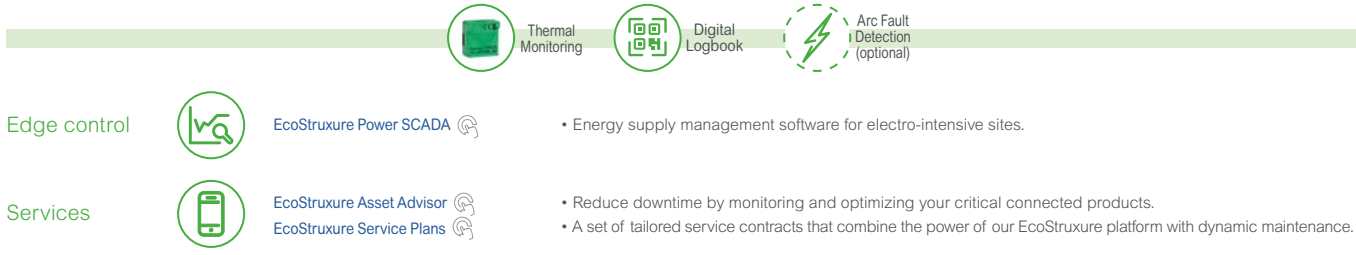

Decarbonizing and electrifying faster with Schneider Electric Services

Service Lifecycle Management

Our passionate Service Experts and partners are dedicated to extend the life of assets and systems while making your operations safe, efficient and resilient everyday.

EcoConsult

- 🔗 [EcoConsult Audit](#)
- 🔗 [EcoConsult Electrical Digital Twin](#)
- [EcoConsult System Studies](#)
- [EcoConsult Design](#)

Consult & Audit

- Start your assessment journey to discover the untapped efficiencies that lie into your installations.
- Release the potential of Electrical Digital Twin for operations with enhanced safety and reliability.
- Provide actionable insights to address the safety, resiliency and sustainability of your electrical network.
- Enjoy the high level of expertise of our design consultant for your installations.

EcoCare Membership 🔗

EcoCare membership is a next-generation services plan which offers exclusive benefits and faster access to our experts, on-site and remotely, empowered by advanced analytics to help you minimize electrical failure by up to 75%, reduce on-site activities (planned downtime) and related costs by up to 40% and extend equipment lifespan, helping you avoid carbon emissions.

Members also benefit from faster access to our technical expertise and reduce Mean-time-to-repair, plus leverage our dedicated Customer Success Management team to you achieve your business goals.

Next generation service plan

EcoFit™ Circularity & Repairability Innovative Modernization Services

EcoFit™ offers an innovative approach to your electrical, critical power, cooling and automation system modernization, focusing on Circularity & Repairability. By embracing this concept, your business can thrive in the circular economy, reducing carbon footprint.

- [Life Extension Essential](#)
 - We help extend the lifetime of your equipment by up to 25% with sensors, advanced monitoring and condition-based maintenance.
- [Life Extension Advanced](#)
 - We only replace the core components of your equipment, avoiding the manufacturing of new products to reduce waste by up to 90%.
- [Replacement](#)
 - We assist you in achieving environmental compliance by efficiently recovering SF6 gas and recycling raw materials from your end-of-life equipment.
- [Recovery](#)
 - We take back and refurbish products at the same level of performance requested by market standards.

Digitization enhances operational safety and efficiency

The power of digital

Powerful digital capabilities deliver the high efficiency you have come to expect from a Schneider Electric switchgear. The health status of the device can be monitored via wireless sensor-based technology and digital tools. Because of this, condition-based maintenance can take place at the right time, meaning fewer downtime risks and costs.

Thermal monitoring

- Sensors detect hotspots at faulty cable connections, enabling users to take preventive action.

Environmental monitoring

- Temperature and humidity sensors measure condensation helping user prevent fast aging.

Circuit breaker monitoring

- Monitoring of the circuit breaker's health and status for preventive maintenance.



Enhanced operational safety

As a digital, connected switchgear, SM AirSeT enables nearby control features. It allows users to operate and monitor the switchgear from a smart device, enabling staff to do their jobs without physically interacting with the equipment. Built-in arc-flash detection reduces the risk of damage to the device and enhances the safety of on-site personnel.

As an SF₆-free, air-insulated switchgear, SM AirSeT generates no alternative gases or toxic byproducts from current breaking – which also helps enhance the safety of the users and the environment.

Connected and flexible for greater efficiency

Discover powerful connectivity

SM AirSeT also boasts other powerful digital capabilities extending beyond local visibility and maintenance.



Substation monitoring device

Substation monitoring communicates with a range of sensors embedded in equipment by default. Operate SM AirSeT easily from your smart device or Local HMI, from a safer* distance.



Thermal monitoring

Wireless thermal sensors help detect temperature anomalies, prompting diagnosis of potential faults, reducing downtime and fire risks.



Environmental monitoring

Wireless humidity sensors monitor environmental impacts, helping detect accelerated aging and optimizing maintenance costs.



Circuit breaker monitoring

Monitoring of the circuit breaker's health and status for preventive maintenance.



Digital Logbook

Quickly connect to SM AirSeT by EcoStruxure code to access its dedicated digital logbook, manuals, support and more; designed to save operational time and effort.



Internal arc detection

Optical sensors provide fast internal arc clearance, reducing operator and equipment risk, while reducing equipment damage due to internal arcs.



*Refer to NFPA70E standard

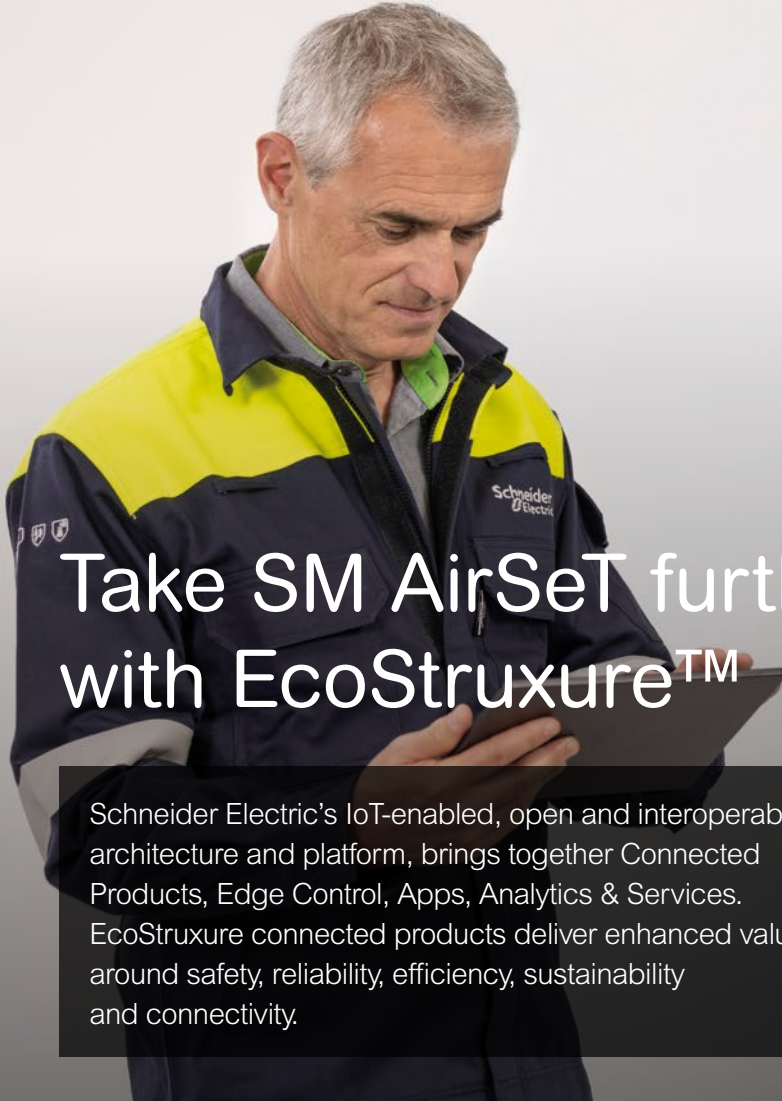

Take SM AirSeT further with EcoStruxure™

Schneider Electric's IoT-enabled, open and interoperable architecture and platform, brings together Connected Products, Edge Control, Apps, Analytics & Services. EcoStruxure connected products deliver enhanced value around safety, reliability, efficiency, sustainability and connectivity.

EcoStruxure ready



Efficient asset management

Boost your efficiency and reduce downtime using predictive maintenance tools.



24/7 connectivity

Make better informed decisions with real-time data that is available everywhere, anytime.



Enhanced safety

Advanced features designed-in and based on well-known designs, experience and technology.

EcoStruxure™ Innovation At Every Level

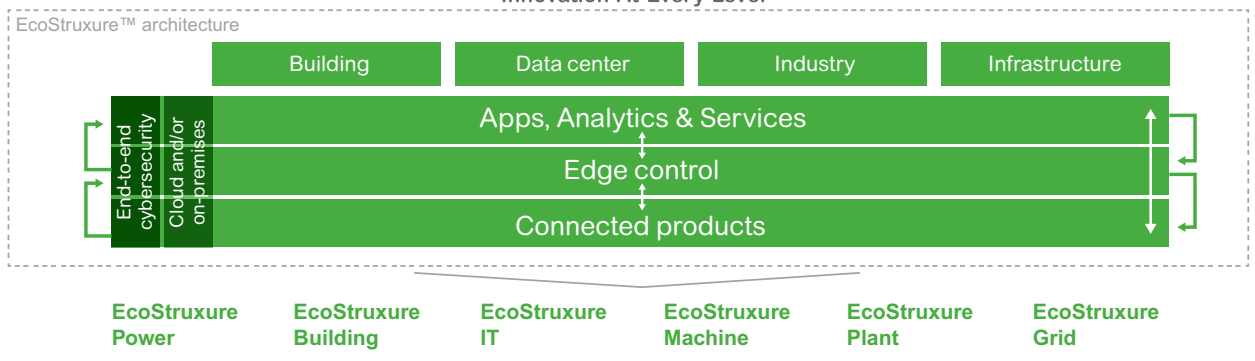

Pure air technology validated with customers

Schneider Electric has engaged like-minded companies in the utility, commercial and industrial buildings sectors, such as GreenAlp, EEC Engie New Caledonia and E.ON Sweden. They participated in a variety of pilot projects, where the new SF₆-free switching technology is operational today.

More and more sustainability-orientated customers, like Renault in France, have deployed SM AirSeT as an essential part of their green strategy.

Recognized by experts

Pure air medium-voltage switchgear technology has been recognized by industry experts appreciating a design which delivers enhanced performance on the one hand and enables climate positive action on the other.



GreenAlp in France

Green and digital SF₆-free MV switchgear helps a utility provide reliable power to a city with sustainable aspirations.

[Visit the website to discover more.](#)

EEC Engie in New Caledonia

Innovative culture is driving EEC Engie's pursuit of new solutions to help them and their customers reach their sustainability ambitions.

[SF₆-free pure air MV and EcoStruxure are paving the way.](#)

E.ON in Sweden

Sweden's largest energy distributor achieves greater sustainability and reliability with SF₆-free medium-voltage technology and EcoStruxure for Power & Grid solutions.

[Discover more about this project.](#)

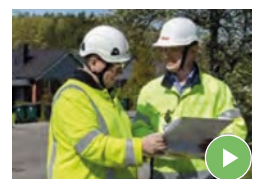

Overview

The experience of a world leader	14
Fields of application	15
EcoStruxure™ solutions	17
What is EcoStruxure™?	17
EcoStruxure™ Power	18
EcoStruxure™ Connected product	19
Offer structure	19
Active	20
Active Plus	21
EcoStruxure™ ready solutions	22
EcoStruxure™ Asset Advisor	22
Protecting the environment	23
Quality assurance	24
Quality certified to ISO 9001	24
BIM models	25

The experience of a world leader

Schneider Electric's experience in this product category started more than 45 years ago. 2.5 Million cubicles later, SM AirSeT is the latest in this strong heritage. Current breaking technology also spans more than 30 years, a long field experience for our latest designs.

This experience means that today Schneider Electric can propose a complementary range: vacuum type circuit breaker cubicles up to 24 kV and standard or enhanced internal arc withstand cubicles to help reinforce the safety of people according to the IEC standard.

This gives you the benefit of unique experience: that of a world leader, with over 2,500 000 Medium Voltage units installed throughout the world.

We have combined this extensive experience with strong focus on customer needs to develop SM AirSeT, a new, green generation of medium voltage switchgear.

The modular SM AirSeT is a range of harmonized cubicles with vacuum breaking technology, with a lifespan of 40 years.

These cubicles meet all your Medium Voltage substation requirements up to 24 kV by superposing their various functions.

The result of in-depth analysis of your requirements, both now and in the future, SM AirSeT cubicles mean that you can take advantage of all the features of both a modern and proven technology.



1975 - Innovation:

VM6 with an MV switch for MV/LV transformer substation is launched.

1989 - Experience:

Over 300,000 VM6 cubicles equipped networks throughout the world.

1991 - Innovation and Experience:

Cumulated with the second generation of SM6 modular SF₆ cubicles.

2015 - A leading position:

Schneider Electric consolidates its position as uncontested leader in the Medium Voltage field.

2020:

Thermal sensor TH110 is fitted from factory by default in cable terminations for all the relevant cubicles sold in private market.

2021:

SM AirSeT range.

SM AirSeT cubicles are used for the medium voltage (MV) section in MV/LV transformer substations in public distribution systems and MV consumer or distribution substations up to 24 kV.

The SM AirSeT is made up of modular cubicles containing fixed, disconnectable metal-enclosed switchgear, using air as the main insulation. The cubicles are:

- Switch-disconnector
- EvoPacT vacuum circuit breaker
- Vacuum contactor
- Disconnecter

MV/LV transformer substations

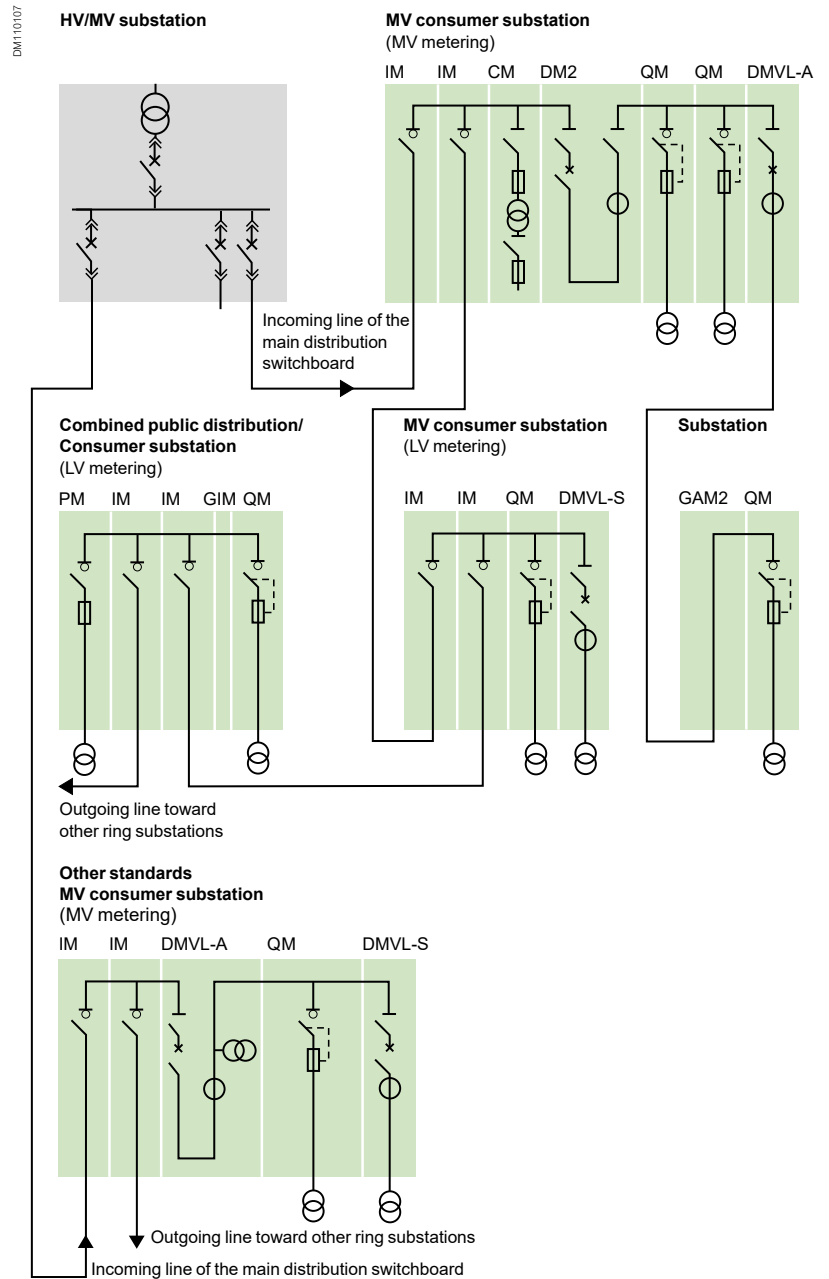

Industrial distribution substations

PM105388



DM110108

HV/MV substation

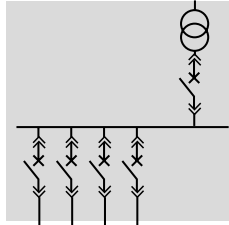

Cubicle definitions

Below is the list of SM AirSeT units used in MV/LV transformer substations and industrial distribution substations:

- **IM, IMC, IMB, IMM** switch
- **PM** switch-fuse
- **QM, QMC, QMB** switch-fuse combination
- **DMVL-S, DMVL-D, DMVL-M** single-isolation disconnectable vacuum type circuit breaker laterally-mounted
- **DM2** double isolation disconnectable vacuum breaker
- **CM, CM2** voltage transformers
- **GBC-A, GBC-B** current and/or voltage measurements
- **NSM-cables** for main incoming and standby
- **NSM-busbars** for main incoming and cables for standby
- **GIM** intermediate bus unit
- **GBM** connection unit
- **GAM2, GAM** incoming cable connection unit
- **SM** disconnector
- **TM** MV/LV transformer unit for auxiliaries
- Other units, consult us

Distribution switchboard

DMVL-A GBC-B QM QM IM IM IMB GBM QM DMVL-S GBC-B DMVL-A

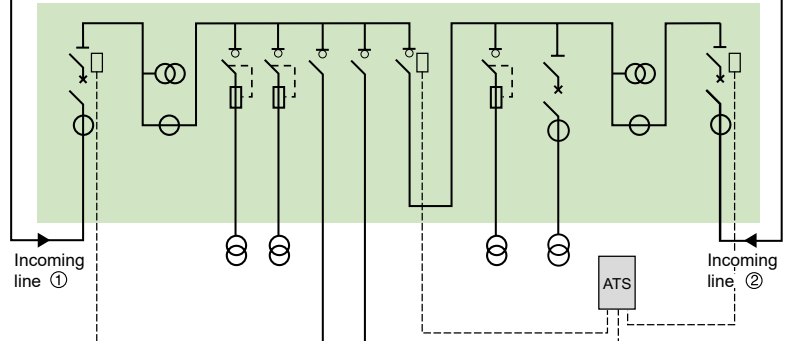

MV/LV transformer substations

QM NSM-busbars GBM SM TM

NSM-cables QM CVM CVM DMVL-W

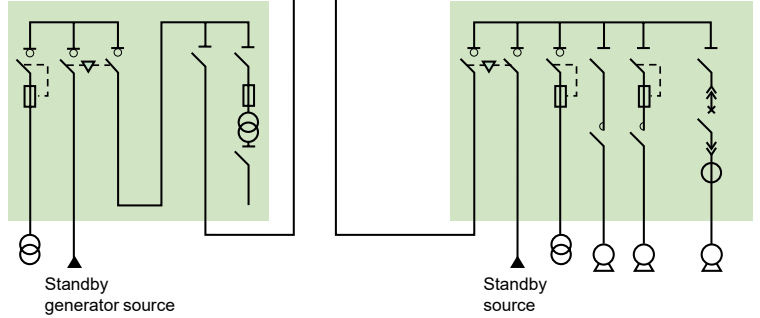

Distribution switchboard

QM QM GBC-B IM IMB GBM IM GBC-B DMVL-S DMVL-S

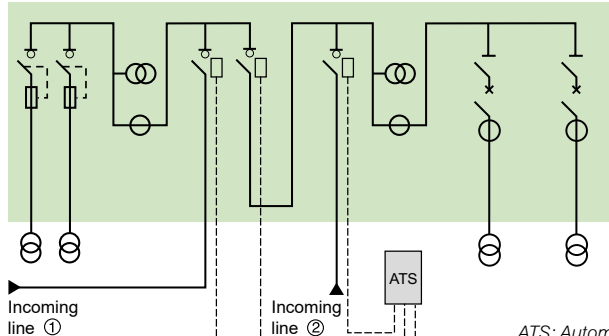

ATS: Automatic Transfer System

EcoStruxure™ solutions

What is EcoStruxure™?

500 000

EcoStruxure™ has been deployed in almost 500 000 sites with the support of some 20 000 developers, 650 000 service providers and partners, and 3 000 utilities, and connects over 2 million assets under management.

EcoStruxure™ ready



Efficient asset management

Greater efficiency with **predictive** maintenance helping to reduce downtime.



24/7 connectivity

Real-time data **everywhere anytime** to make better informed decisions.



Increased protection

Proven design and experience combined with **internal arc designs** to enhance people and equipment protection.

EcoStruxure™ is our open, interoperable, IoT-enabled system architecture and platform. EcoStruxure delivers enhanced value around **safety, reliability, efficiency, sustainability, and connectivity** for our customers. EcoStruxure leverages advancements in IoT, mobility, sensing, cloud, analytics, and cybersecurity to deliver Innovation at Every Level. This includes Connected Products, Edge Control, and Apps, Analytics & Services, which are supported by Customer Lifecycle Software.

Turn data into action

EcoStruxure™ architecture lets customers maximize the value of data.

Specifically, it helps them:

- Translate data into actionable intelligence and better business decisions
- Take informed decisions to help in securing uptime and operational efficiency thanks to real-time control platforms
- Gain visibility to their electrical distribution by measuring, collecting, aggregating, and communicating data

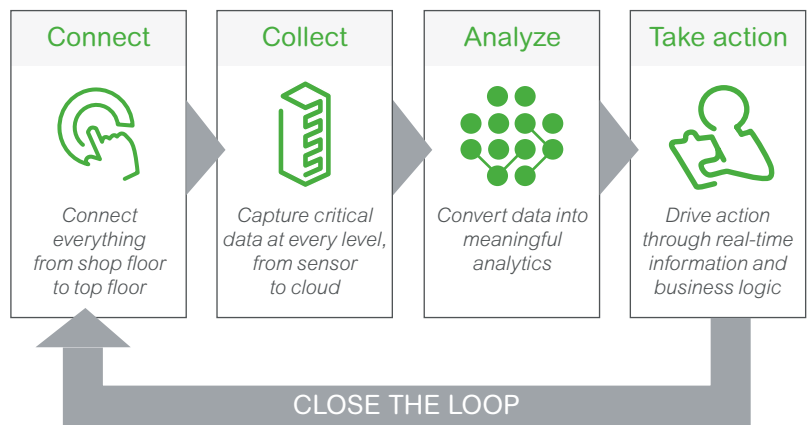

DM110109

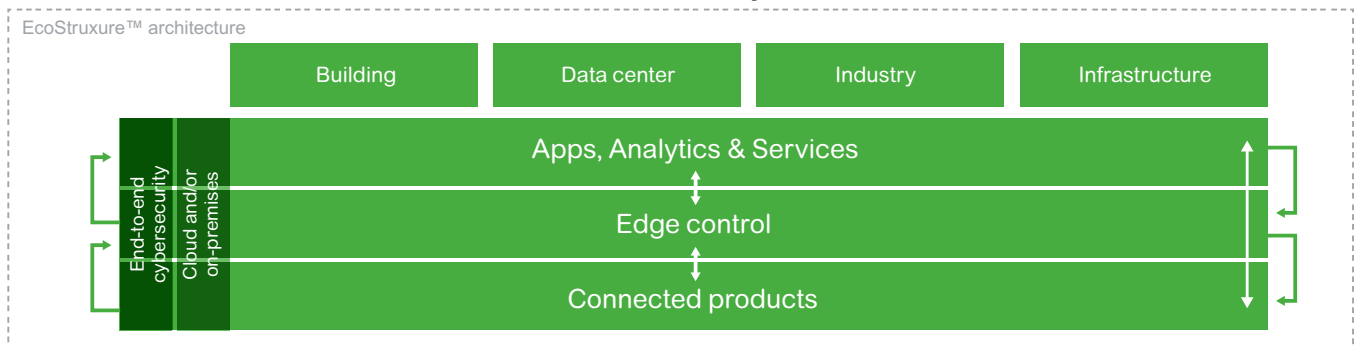

EcoStruxure Power

EcoStruxure Building

EcoStruxure IT

EcoStruxure Machine

EcoStruxure Plant

EcoStruxure Grid

EcoStruxure™ solutions

EcoStruxure™ Power

EcoStruxure™ Power is one of the six domains of EcoStruxure™, our IoT-enabled architecture and platform.

EcoStruxure™ Power plays a key role in all four end markets (Building, Data Center, Industry, and Infrastructure). This involves bringing the world of electrical distribution to those end markets.

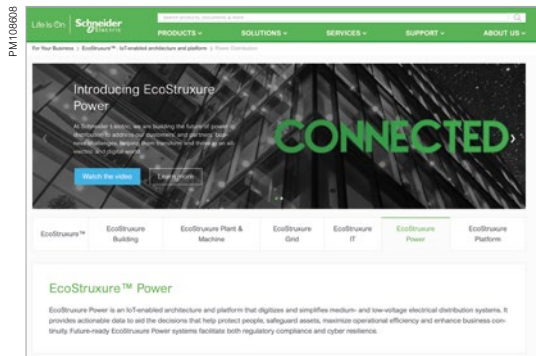
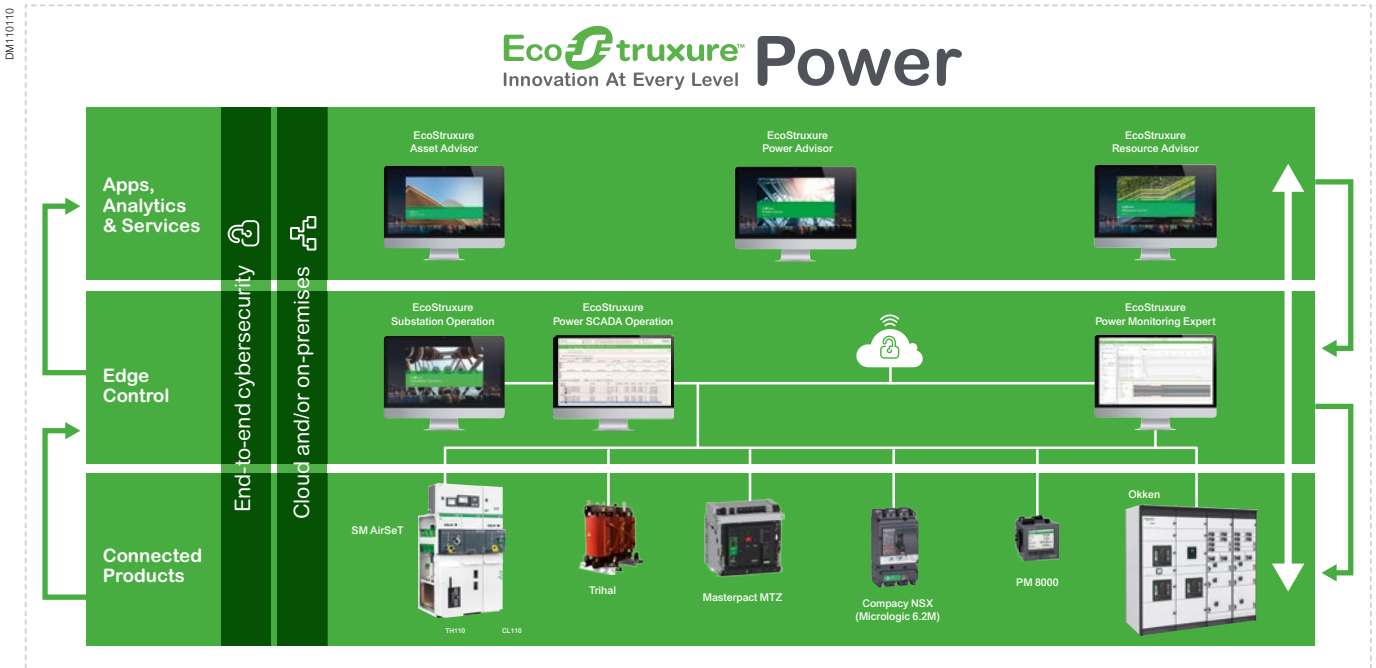

EcoStruxure™ Power digitizes and simplifies low and medium voltage electrical distribution systems. It provides essential data to aid the decisions that help protect people, safeguard assets, maximize operational efficiency and business continuity, and maintain regulatory compliance.

EcoStruxure™ Power is an open architecture and platform designed with the intention of making it easy to add, upgrade, and swap components. The world is full of electrical distribution systems in various stages of maturity, produced by a variety of manufacturers. Interoperability with EcoStruxure™ Power is essential to making these power distribution systems future ready. The added benefit of a holistic Schneider Electric system is plug-and-play connectivity to achieve faster and lower risk integration and commissioning.

EcoStruxure™ Power architectures are cost-optimized to deploy, using only the right technology to deliver the desired business outcomes for our customers – no more, no less. However, customer needs or demands change over time.

The EcoStruxure™ Power system is scalable from light commercial and industrial buildings to critical facilities such as hospitals and data centers, or infrastructure such as airports, rail, and oil and gas. The scalability of EcoStruxure™ Power means that it also grows and evolves with changing needs or demands through its modular architecture.

EcoStruxure™ Power architectures are fully flexible power distribution systems with the ability to adapt to dynamic and ever-changing conditions, such as balancing supply and demand by the hour or minute or adding and then scaling on-site renewable generation capabilities over time. Connecting IT and OT systems into a single, easy-to-manage Ethernet IP network is at the heart of our digitization story. With EcoStruxure™ Power, facility managers can use the data they collect to make realtime decisions to maximize business continuity and optimize operations.

More about
EcoStruxure™ Power
se.com/ww/ecostruxure-power



EcoStruxure™ Connected product

Offer structure

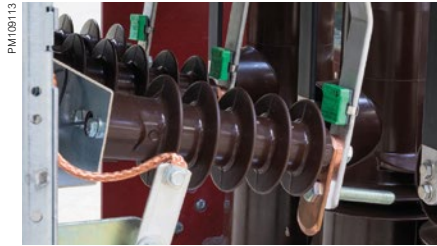

Connected by default

Digitization provides an opportunity to take real benefits of data, cloud and analytics with power system equipment. Our latest SM AirSeT equipment offers extensive digital benefits and connectivity by default in the standard product.

- Ready for today and tomorrow, equipment has embedded IoT sensors to provide data to monitor critical components and connections, and the installation environment.
- Essential data can be easily shared via on-premises or on-cloud architectures, connected to various applications to help users benefit from data.
- Nearby or remote connectivity allows users to monitor or control power system equipment from a safer distance, without even visiting the substation'
- 24/7 data helps maintenance teams greatly improve efficiency and reliability. Respond to problems faster, and be better prepared for site visits.

Not only connected by default, IoT data enables optional digital services, like EcoStruxure Asset Advisor. These services can give you smart alarms or data analytics that help you start your journey to predictive maintenance, efficient asset management and much more.

Find more information [Here](#)

Our SM AirSeT is bringing new functionalities and therefore new opportunities. In parallel, our customer needs are diverse and raise different expectations. For this reason, we have introduced 3 scalable tiers of connectivity to better meet your needs.

	SM AirSeT	SM AirSeT Active	SM AirSeT Active Plus
Thermal monitoring - 24/7	✓	✓	✓
EcoStruxure digital logbook	✓	✓	✓
Environmental monitoring - 24/7	✓	✓	✓
EcoStruxure Service Plan		✓	✓
Condition monitoring alarms		✓	✓
HMI		✓	✓
Partial discharge monitoring			✓
Arc flash detection	✓	✓	✓
Remote Terminal Unit		✓	✓
Edge and cloud connectivity ⁽¹⁾		✓	✓

Included
 Optional

(1) Edge and cloud connectivity comprise the optional software offers:
 -EcoStruxure Power SCADA
 -EcoStruxure Asset Advisor



EcoStruxure™ Connected product

Active

- **24/7 connectivity**
Real-time remote data for effective decision making, anywhere, anytime.
- **Efficient asset management**
Increase uptime while also reducing maintenance costs and risks.

Active features

The Active tier features devices with native and systematic connectivity to the internet, helping your daily tasks with a boost of efficiency and sustainability. Switchgear health (condition monitoring) can be connected 24/7, providing:

- Thermal monitoring
- Environmental monitoring
- Circuit breaker monitoring
- Connectivity gateway to SE Cloud
- QR Code access to a Digital Logbook and product information via [EcoStruxure Facility Expert](#) 
- Optional services: [EcoStruxure Asset advisor](#) 



DM110111

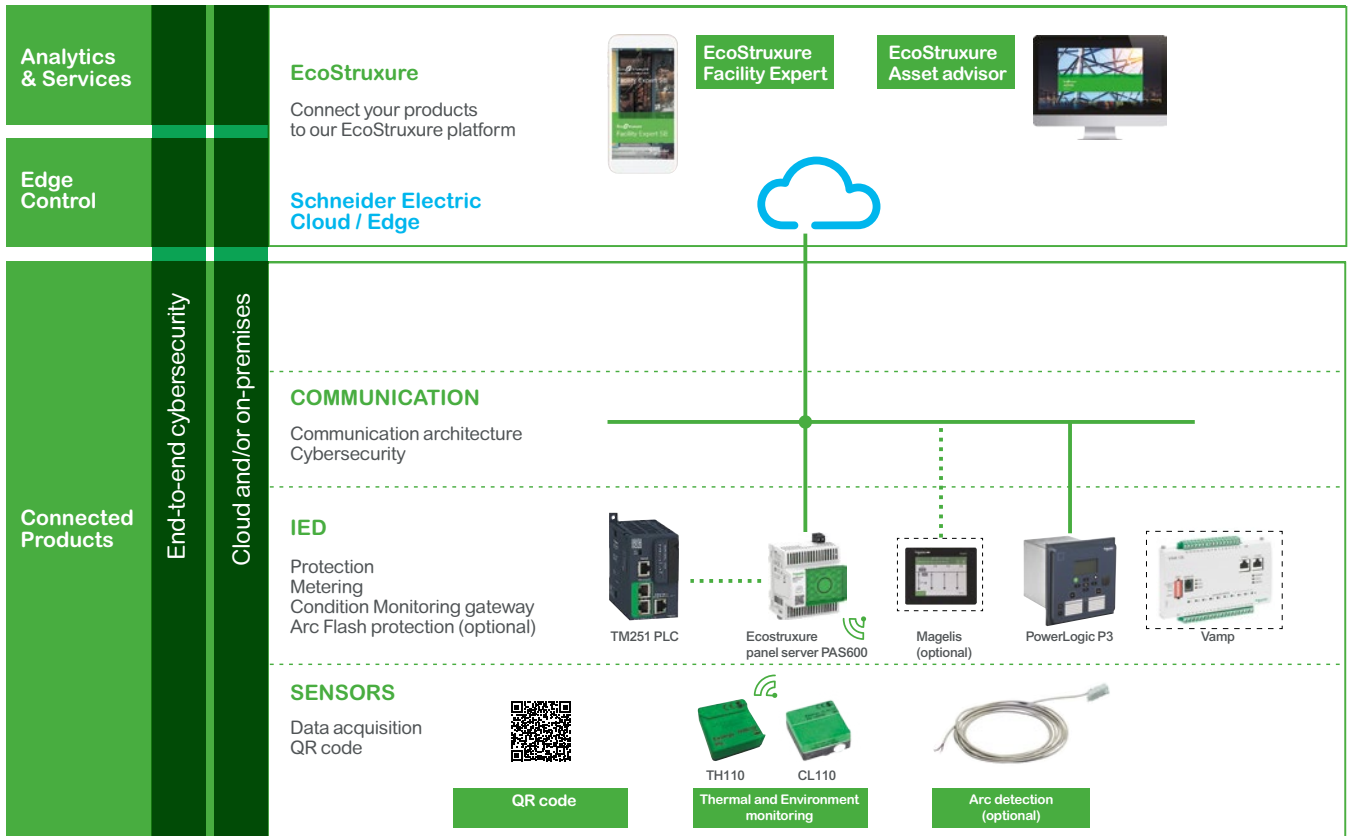

EcoStruxure™ Connected product

Active Plus

- **Helping enhance safety**
For both operator and equipment.
- **24/7 connectivity**
Real-time remote data for effective decision making, anywhere, anytime.
- **Efficient asset management**
Increase uptime while also reducing maintenance costs and risks.
- **Open Intelligence Edge Layer**
Decision and Control capabilities from Edge layer for all devices.

Active Plus features

Devices with native and systematic connectivity to the internet actively monitor and control at the Edge and from the Cloud.

- Thermal monitoring
- Environmental monitoring
- Circuit breaker monitoring
- Partial discharge monitoring
- Connectivity gateway to SE Cloud
- QR Code access to a Digital Logbook and product information via EcoStruxure Facility Expert
- Optional services:
EcoStruxure Asset advisor
[EcoStruxure service plan](#)
- Local edge monitoring & control:
EcoStruxure Power SCADA



DM110112

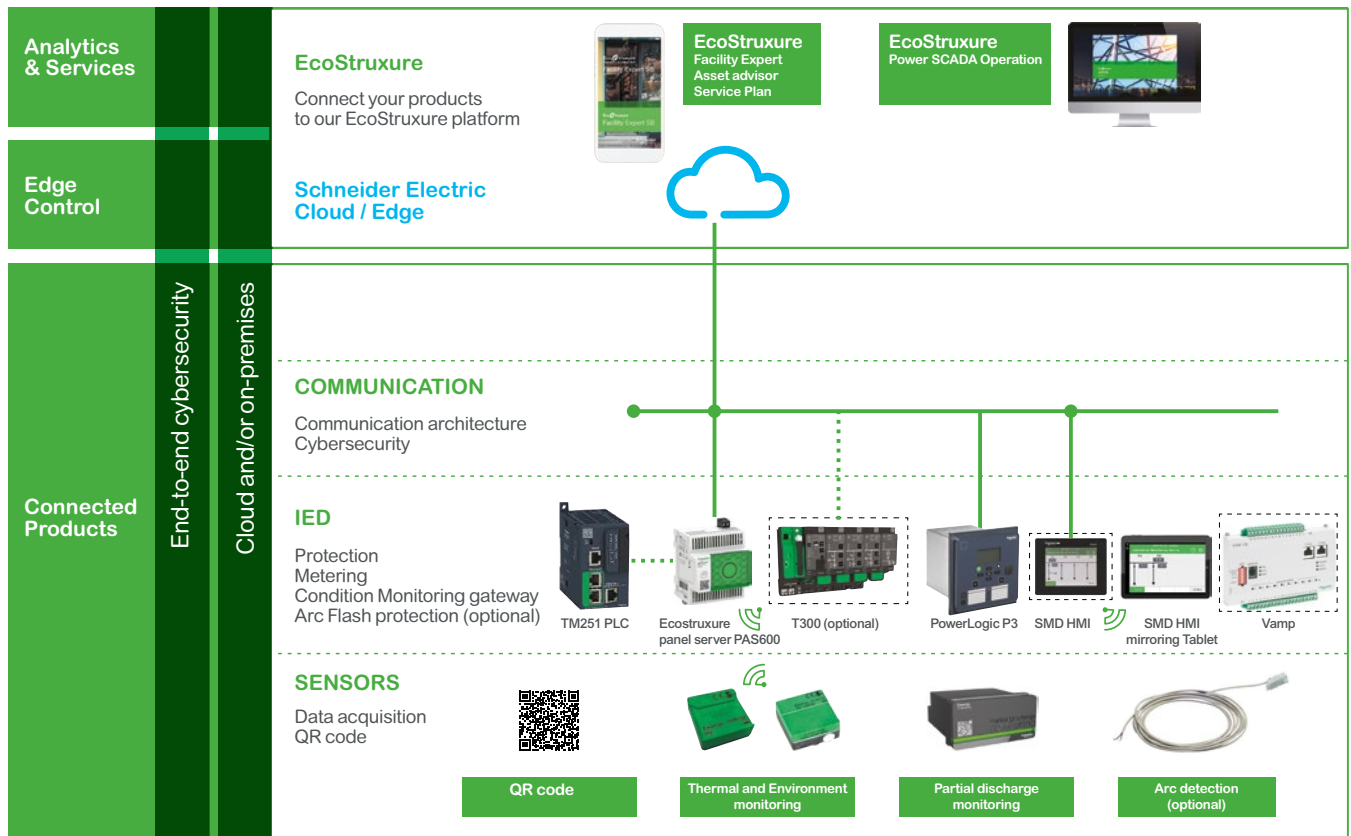

EcoStruxure™ ready solutions

EcoStruxure™ Asset Advisor

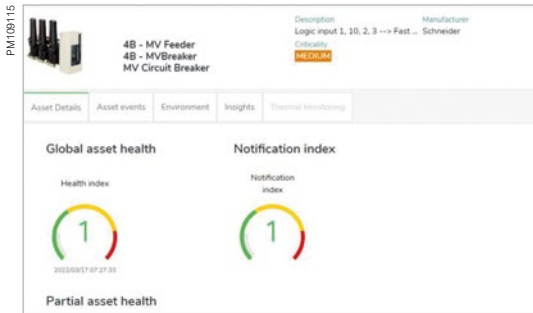

Asset Advisor Dashboard

Mitigate and anticipate potential electrical failure

Imagine having access to key data about your electrical distribution equipment whenever you need it. And experienced professionals who can help you make better informed decisions.

That is what you get with EcoStruxure Asset Advisor from the Schneider Electric Connected Services Hub.

You know exactly which assets need to be serviced or replaced to help you better plan your expenses.

Are you

- Planning to introduce condition-based maintenance (beyond corrective and regular maintenance) with benefits associated with reduced time to address an issue?
- Looking for innovative solutions to scale your corporate reliability programs? Before now used mainly on rotary machines.



Asset Health Matrix

Our EcoStruxure Asset Advisor solution

- Supports your journey into predictive maintenance
- Designed to mitigate risk of failure and optimize maintenance
- Turns your data into short-term actions and long-term decisions
- Our platform is ready to use by plug-in connectable electrical assets under our flexible model
- EcoStruxure Asset Advisor brings tangible benefits on failure risk mitigation and maintenance optimization

Cybersecurity best practices include:

- Data collected through secured gateways
- Secured data transport to help prevent data access or manipulation
- Your data is hosted in the Schneider Electric Data Center
- Results displayed on cybersecured dashboard (reports, diagnostics, notifications, etc.)
- You remain the owner of your data

Click [here](#) to download the free version of EcoStruxure Asset Advisor

Operational performance

- Fewer unscheduled downtimes
- Increased asset useful life
- Shorter time to fix
- Better compliance with regulations

Financial efficiency

- Lower total cost of ownership (TCO)
- Decreased failure cost
- Decreased average maintenance cost/fix

Safety

- Helping reduce personal risk through:
 - Maintenance expertise and continuity in high turnover environment
 - Early warning of impending equipment failure

Peace of mind

- New asset ecosystem insights
- Consistent on-site experience
- Right people at the right time

Schneider Electric is committed to a long term environmental approach.

Environmental performance

All necessary measures have been taken in conjunction with our services, suppliers and subcontractors to help ensure that the materials used in the composition of the equipment do not contain any substances prohibited by regulations and directives.

This has led to the development of SM AirSeT, which contains no SF₆ gas and is insulated with air, together with vacuum breaking. This means no concerns about toxic byproducts and end-of-life gas recycling.

It also mean no concerns about any future regulatory bans of SF₆ alternative gases.

Our Air Insulated Switchgear is designed with environmental protection in mind:

- The materials used in, insulators and conductors are identified, easily separable and recyclable.

The environmental management system adopted by Schneider Electric's production sites for the manufacture of our Air Insulated Switchgear has been assessed and recognized as conforming to the requirements of the standard ISO 14001.

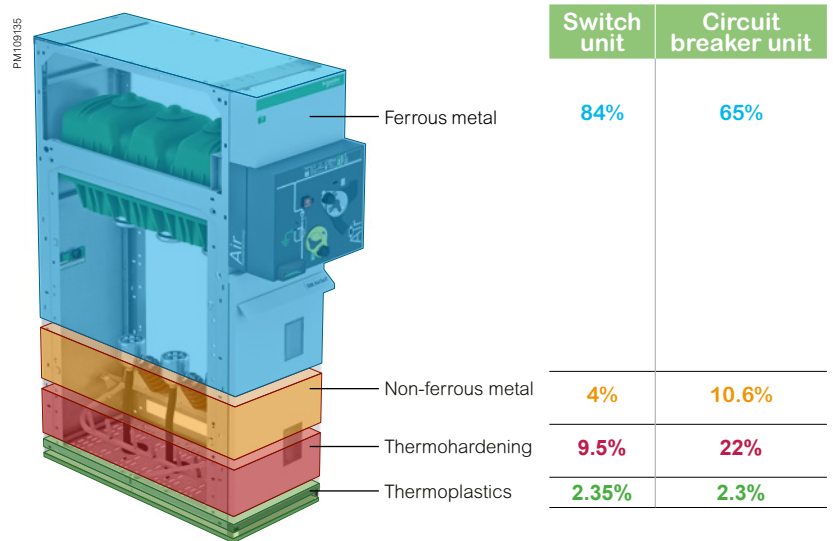

The environmental management system adopted by Schneider Electric production sites which produce the SM AirSeT have been assessed and judged to be in conformity with requirements in the standard ISO 14001.

Quality assurance

Quality certified to ISO 9001



A major advantage

Schneider Electric has integrated a functional organization into each of its units. The main mission of this organization is to check the quality and the compliance with standards. This procedure is:

- Uniform throughout all departments
- Recognized by many customers and approved organizations.

But it is above all its strict application has enabled recognition to be obtained by an independent organization: The **French Quality Assurance Association (FQAA)**.

The quality system for the design and manufacture of SM AirSeT units has been certified in conformity with the requirements of the ISO 9001: 2000 quality assurance model.

Meticulous and systematic controls

During manufacture, each SM AirSeT is subject to routine testing which aims to check the quality and conformity according to standards:

- Tightness testing
- Mechanical operating test
- Main circuit resistance measurement
- Power Frequency test
- Conformity with drawings and plans

The results obtained are recorded on the internal test report for each device by the quality control department.



A unique opportunity to improve the key driver of the Building market
Still Interoperability is a challenge

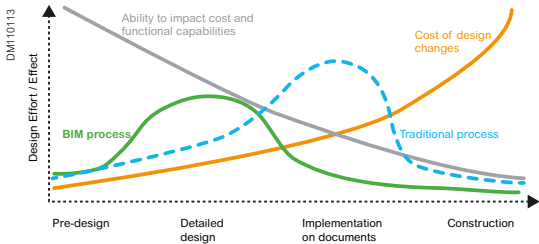

What is BIM

- BIM is an evolution of the Computer Aided Design (CAD) and modeling software market and key to digitization
- It improves on traditional CAD drawings by not only including geometry, but also information that helps in technical and budget calculations
- BIM also refers broadly to the collaborative processes between and or within companies to leverage the value of the models throughout the building design & lifecycle
- Helps create, construct, manage and operate projects more economically and with less environmental impact

Customer requirements



- High value business



- Reduce time and effort required for work.
- Pain: disconnected tools and incapability to share and interact with each other



- Project management across multiple design environment, colleagues and stakeholders is inefficient and not productive.
- Pain: no collaborative platform to support seamless experience for electrical industry to perform electrical tasks and share across companies and geographies.

Benefits of BIM

- Save time on designs
- Decrease project costs
- Improves co-ordination and collaboration
- Minimizes risk
- Helps to easily maintain building lifecycle

BIM and the Building Lifecycle

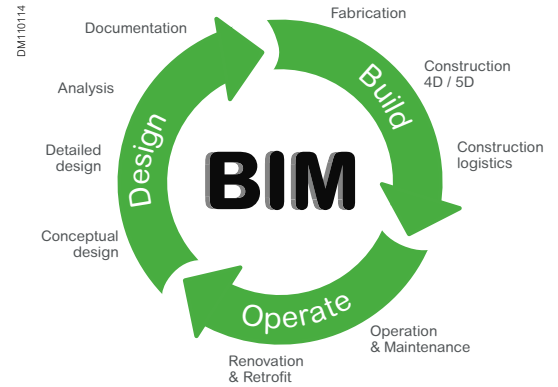

SM AirSeT BIM repositories

https://www.bimobject.com/en/schneider/product/SM_AirSet



SM AirSeT 3D drawings

- **Objective :**
3D drawings are useful for the our partners (contractor & panel builders) for simulating the installation conditions (fixation points, connection points etc) in a 3D environment.
- **Customer values:**
Reduction of design time. Reduce chances of mistake at installation site.

Range description

General characteristics	27
Units for switching functions	29
Units for protection functions	30
Units for metering functions	32
Units for other functions	33
Factory-built cubicles	34
Description	34
Compartments and devices	35
Description	35
Switchgear	37
Operating mechanism safety	38
Operating principle	39
Safety of people	41
Internal arc protection	41
Operating conditions and standards	43

Electrical characteristics



PM11031

		Rated voltage					
		Ur	kV	7.2	12	17.5	24
Insulation level							
Insulation	Ud	50/60 Hz, 1 min (kV rms)	20	28	38	50	
Isolation			23	32	45	60	
Insulation	Up	1.2/50 μ s (kV peak)	60	75	95	125	
Isolation			70	85	110	145	
Breaking capacity							
Rated current	Ir	A	400 - 630 - 1250				
Short time withstand current	Ik/tk (1)	kA/1 s	12.5	400 - 630 - 1250			
			25	630			
		kA/3 s	16	400 - 630 - 1250			
			20	400 - 630 - 1250			
Making capacity (50/60 Hz)	Ima	kA	62.5	630			
			50	630			
			40	630			
			31.5	400 - 630			
Maximum breaking capacity							
Units IM, IMC, IMB	A		630				
NSM-cables, NSM-busbars	A		630				
QM, QMC, QMB	kA		25	20			
PM	kA		25				
CVM	kA		6.3	N/A			
CVM with fuses	kA		25	N/A			
Vacuum circuit breaker range							
DMVL-A	kA		25	1250			
DMVL-D	kA		25	1250			
DMVL-S	kA		25	630			
DM2	kA		25	630			

N/A: Not Available

(1) 3 phases

Endurance

Switch-Disconnecter endurance classes as general purpose switch (IEC 62271-102 & 103)				
Classification of mechanical endurance ⁽¹⁾	M0 (normal) = 1 000 M1 = 2 000	M0	M1	M2
	M2 (extended) = 10 000 operations			●
Classification for current breaking	E1 = 10 - 2 E2 = 30 - 3	E1	E2	E3
	E3 = 100 cycles at full load and 0.7p.f. - 5 at I _{ma}			●
Classification for capacitive switching and probability of restrike	C1 = capacitive switching		C1	C2
	C2 = capacitive switching restrikes improbable			●
Earthing Switch endurance class (IEC 62271-102 & 103)				
Classification of mechanical endurance	M0 (normal) = 1 000		M0	M1
	M1 = 2 000 CO cycles			●
Classification short circuit making	E1 = 2		E1	E2
	E2 = 5 at I _{ma}			●
Vacuum circuit breaker: DMVLA cubicle (IEC 62271-102 & 100)				
Disconnecter (1 000 operations)	Classification of mechanical endurance	M0		
		●		
EvoPacT circuit breaker	Classification of mechanical endurance	M0	M1	M2
				●
	Classification of current breaking		E1	E2
				●
Internal arc withstand (in accordance with IEC 62271-200)				
SM AirSeT	Basic	IAC: A-FL, 12.5 kA 1 s		
	Advance	IAC: A-FLR, 12.5 kA 1 s		
		IAC: A-FL & IAC: A-FLR, 16 kA 1 s		
		IAC: A-FL & IAC: A-FLR, 20 kA 1 s		

(1) Depending upon the type of mechanism the endurance level differs.

Protection index

- Classes: PI (insulating partition)
- Loss of service continuity classes: LSC2A (LSC1 for metering GAM/GBM functions)
- Units in switchboard: IP3X
- Between compartments: IP2X
- Cubicle: IK08.

Electro-magnetic compatibility

- Relays: 4 kV withstand capacity, as per IEC 60255-26 for Zone A
- Compartments:
 - Electrical field:
 - 40 dB attenuation at 100 MHz
 - 20 dB attenuation at 200 MHz
 - Magnetic field:
 - 20 dB attenuation below 30 MHz
- According to standards IEEE-693/2018 and EN 60068-3/2018.

Temperatures & altitude

The cubicles must be stored and installed in a dry area free from dust and with limited temperature variations.

- For storage: from -40 °C to +70 °C
- For working: from -5 °C to +40 °C
- Altitude: 1 000 m, possible till 3 000 m with impulse withstand voltage and power frequency derating.

Switching

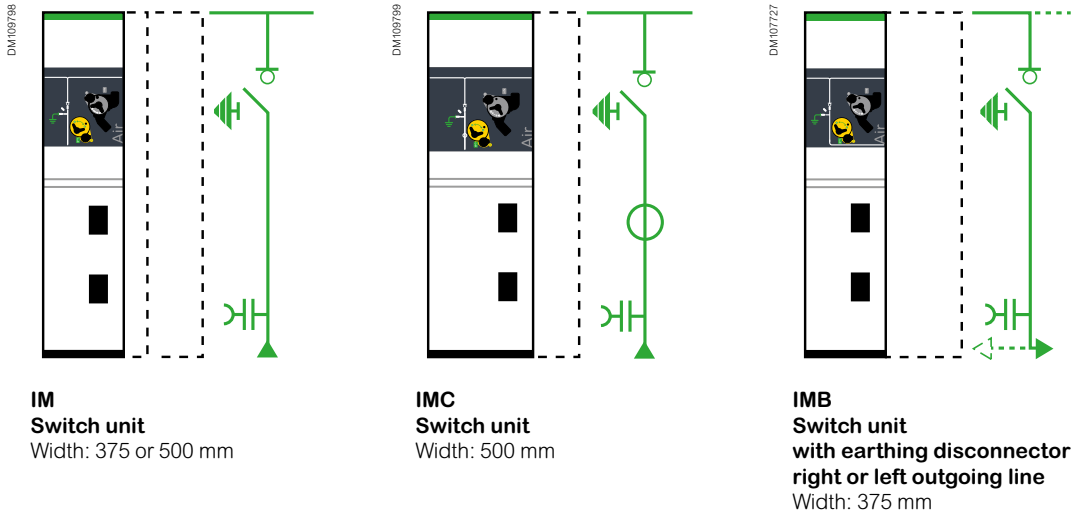

Automatic transfer system

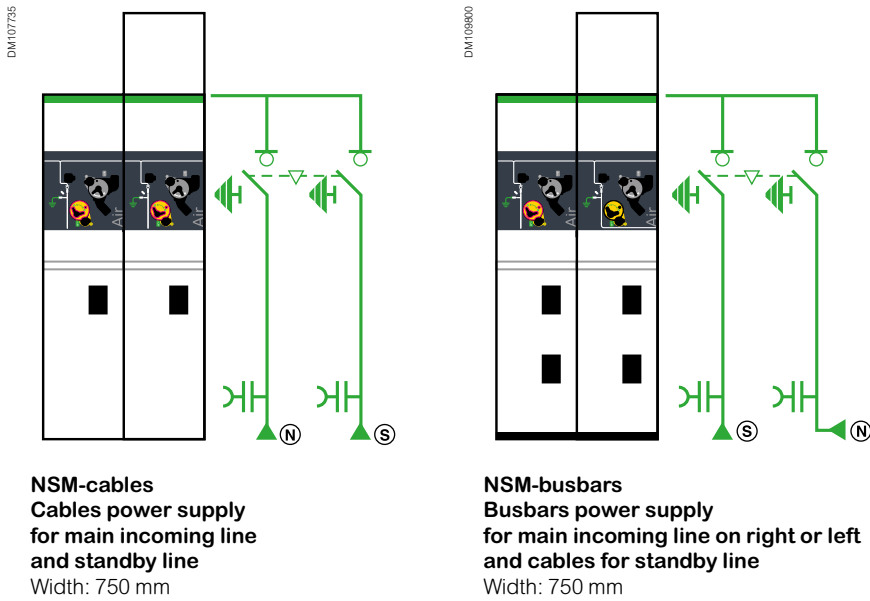

Units for protection function

Switch-fuse

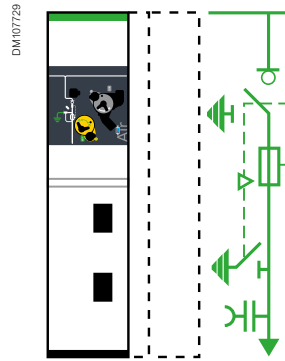

QM
Switch-fuse combination unit
Width: 375 or 500 mm

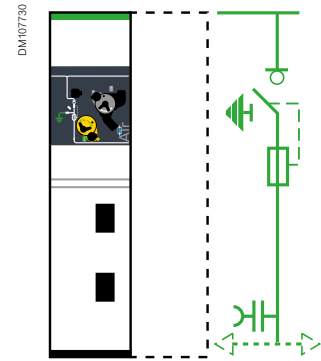

QMB
Switch-fuse combination unit
right or left outgoing line
Width: 375 mm

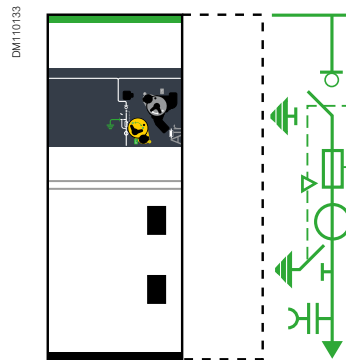

QMC
Switch-fuse combination unit
Width: 625 mm

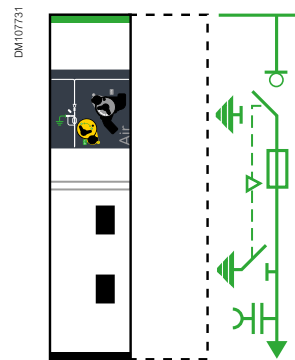

PM
Switch-fuse unit
Width: 375 mm

Vacuum circuit-breaker

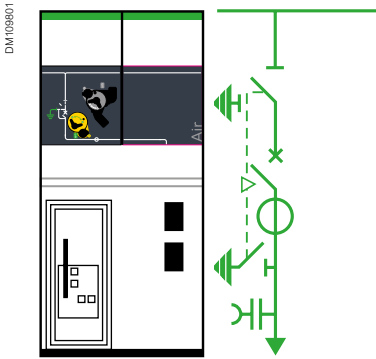

DMVL-A
Single-isolation, disconnectable
circuit breaker unit
Width: 750 mm

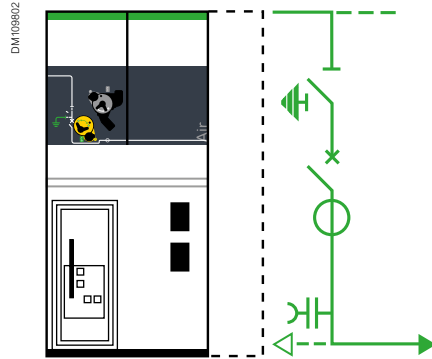

DMVL-D
Single-isolation, disconnectable
circuit breaker unit right or left outgoing line
Width: 750 mm

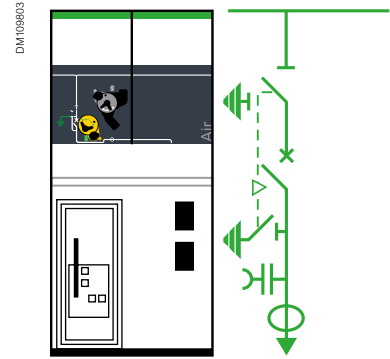

DMVL-S
Single-isolation, disconnectable circuit
breaker unit with autonomous
protection
Width: 750 mm

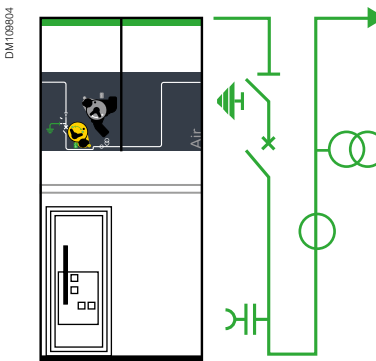

DMVL-M
Single-isolation, disconnectable
circuit breaker and measurement
unit right outgoing line
Width: 750 mm

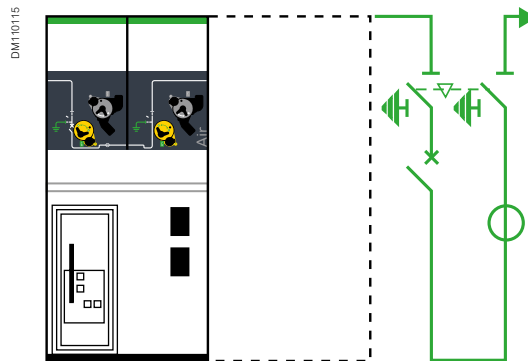

DM2
Double-isolation, disconnectable circuit breaker
unit right or left outgoing line
Width: 750 mm

Units for metering function

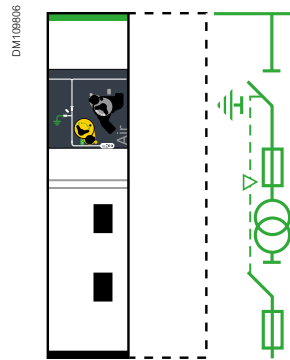

CM
Voltage transformers
with earthed neutral system

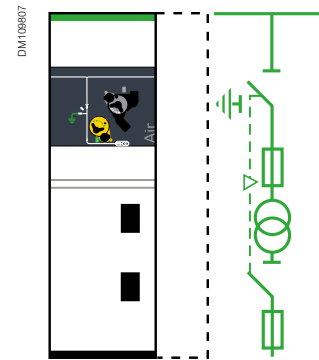

CM2
Voltage transformers
with insulated neutral system
Width: 500 mm

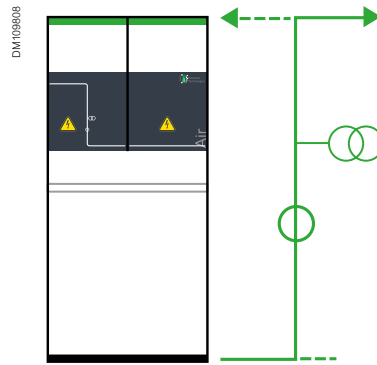

GBC-A
Current and/or voltage
measurement unit
right or left outgoing line
Width: 750 mm

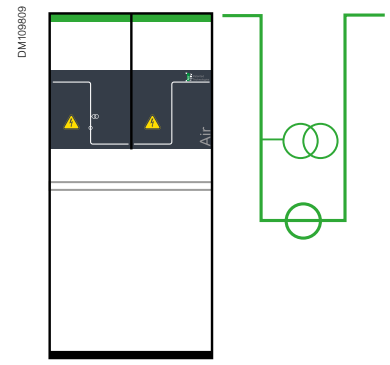

GBC-B
Current and/or voltage
measurement unit
Width: 750 mm

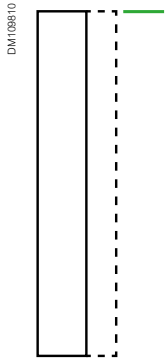

GIM
Intermediate bus unit
Width: 125 mm

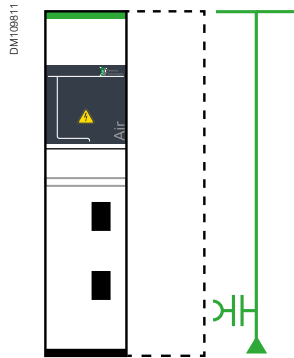

GAM2
Incoming cable-connection unit
Width: 375 mm

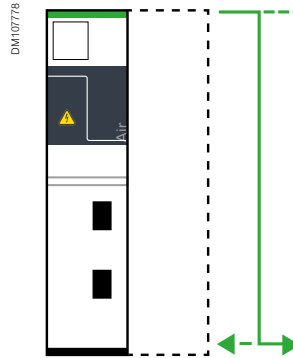

GBM
Connection unit
right or left outgoing line
Width: 375 mm

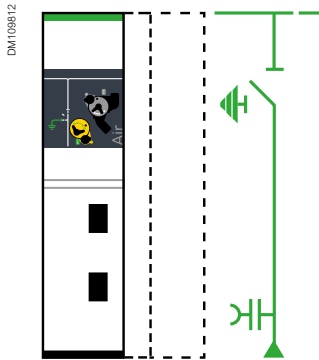

SM
Disconnector unit
Width: 375 mm or 500 ⁽¹⁾ mm
(1) only for 1250 A units.

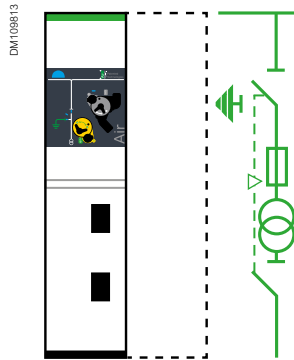

TM
MV/LV transformer unit
for auxiliaries
Width: 375 mm

GAM - coming in Q1/2025, consult us for availability

Factory-built cubicles

Description

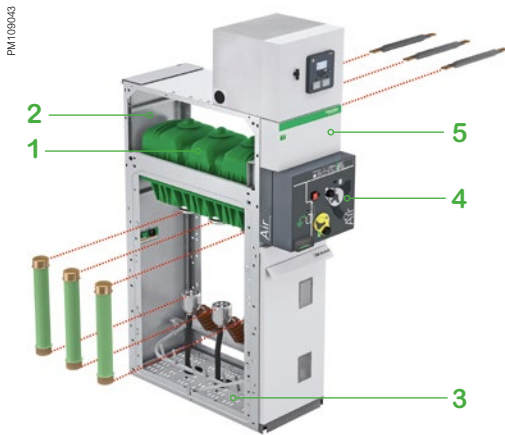

Switch and fuse protection cubicles

1. **Switchgear:** switch-disconnector and earthing switch in an enclosure filled with pressurized air, meeting 'sealed pressure system' requirements.
2. **Busbars:** all in the same horizontal plane, thus enabling later switchboard extensions and connection to existing equipment.
3. **Connection:** accessible through front, connection to the lower switch-disconnector and earthing switch terminals (IM cubicles) or the lower fuse-holders (PM and QM cubicles). This compartment is also equipped with an earthing switch downstream from the MV fuses for the protection units.
4. **Operating mechanism:** contains the elements used to operate the switch-disconnector and earthing switch and actuate the corresponding indications (positive break).
5. **Low voltage:** installation of a terminal block (if motor option installed), LV fuses and compact relay devices. If more space is required, an additional enclosure may be added on top of the cubicle.

Options: please, refer to the chapter 'Function/module description'.

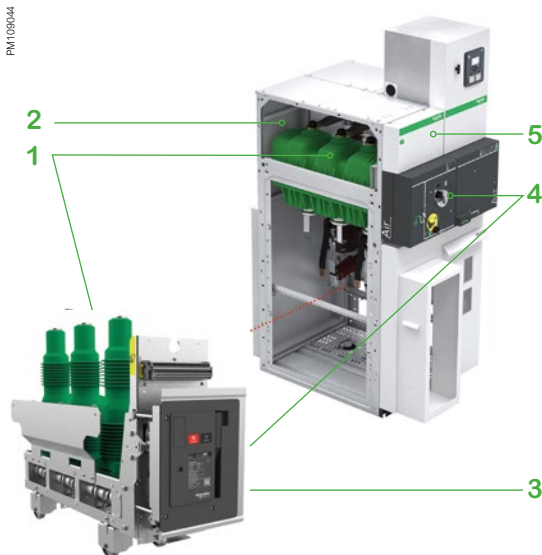

Lateral vacuum type circuit breaker cubicles

1. **Switchgear:** disconnector(s) and earthing switch(es), in enclosure filled with pressurized air and one vacuum circuit breaker, meeting 'sealed pressure system' requirements.
2. **Busbars:** all in the same horizontal plane, thus enabling later switchboard extensions and connection to existing equipment.
3. **Connection and switchgear:** accessible through front, connection to the downstream terminals of the circuit breaker.
- EvoPacT vacuum circuit breaker, associated with an Electronic Protection Relay and standard sensors (with or without auxiliary power supply).
4. **Operating mechanism:** contains the elements used to operate the disconnector(s), the circuit breaker and the earthing switch, and actuate the corresponding indications.
5. **Low voltage:** installation of compact relay devices (VIP) and test terminal boxes. If more space is required, an additional enclosure may be added on top of the cubicle.

Options: please refer to the chapter 'Function/module description'.

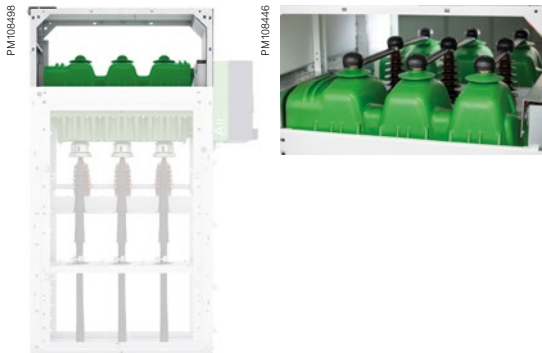

Busbar compartment

The three insulated busbars are parallel-mounted. Connection is made to the upper pads of the switchgear using a field distributor with integrated captive screws.
Ratings 400 - 630 - 1250* A.

(* Available for H2 2024.

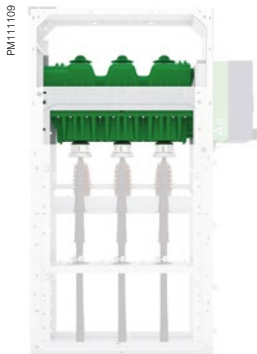

Switching device

This device is separated from the busbar compartment and the connection compartment by the switchgear surrounding the switch, the disconnecter and the earthing switch.

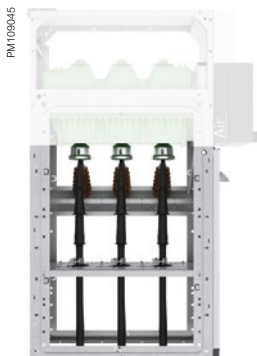

Connection compartment

The network cables are connected:

- To the terminals of the switch
- To the lower fuse holders
- Or to the connection pads of the circuit breaker

Cables may have:

- Cold fitted cable end for dry-type

With basic equipment, the maximum allowable cross-section for cable is:

- 630 mm² or 2 x 400 mm² for 1250 A incoming or outgoing units
- 240 mm² or 2 x 240 mm² for incoming or outgoing units 400 - 630 A
- 95 mm² for transformer protection cubicles incorporating fuses

Refer to the functional units characteristics chapter for each unit's allowable section.

The earthing switch must be closed before the cubicle can be accessed.

The reduced depth of the cubicle makes for easy connection of all phases.

A stud incorporated in the field distributor makes it possible to position and help in securing the cable-end lug with one hand.

Compartments and devices

Description

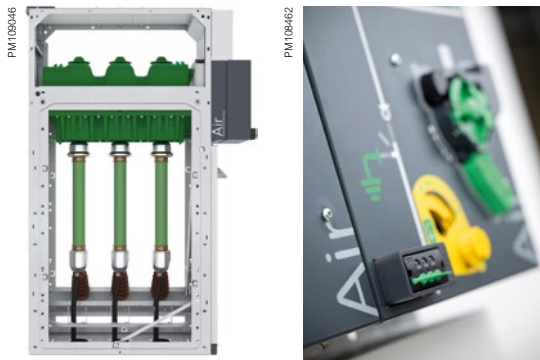

Operating mechanism cover

These covers contain the various operating functions for the:

- Switch and earthing switch
- Disconnectors
- Circuit breaker
- Voltage presence indicator.

The operating-mechanism cover may be accessed with the cables and busbars energized and without isolating the substation.

It also enables easy installation of padlocks, locks and standard LV accessories (auxiliary contacts, trip units, motors, etc.).



Low voltage monitoring control cabinet

It equips the cubicle with low voltage switchgear providing protection, control, status indication and data transmission.

It is available in three versions: cover, wiring duct and cabinet.

- A. LV cover:** enables a very simple low voltage section to be installed, such as indication buttons, push buttons or protection relays.
- B1. LV wiring duct and cabinet:** enables a large majority of low voltage configurations to be installed.
- B2. LV wiring duct and cabinet (240 mm):** enables a large majority of low voltage configurations to be installed. It also can include the arc flash detection VAMP121.
- C. LV control cabinet:** this is only used for larger low voltage accessories or those with a depth greater than 100 mm or complex equipment, such as Sepam series 60 or series 80, converters, control and monitoring units, regulating transformers or dual secondary transformers.

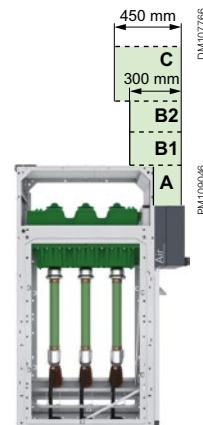

In all cases, these cabinets are accessible, with cables and busbars energized, without de-energizing the substation.

PM111093



EvoPacT circuit breaker

EvoPacT is our latest range of state-of-the-art vacuum circuit breaker.

Its design is the result of more than 40 years of Schneider Electric experience in switching devices. Its wide geographical deployment makes it a key component of SM AirSeT.

It has been designed to suit particularly applications such as: MV/LV transformer substations and industrial distribution substations. The materials used to manufacture this circuit breaker have been selected and designed to operate 10 000 cycles.

PM110056



New Schneider Electric Vacuum Interrupter Bottles

Vacuum interrupter

The heart of the circuit breaker

Vacuum interrupters are the heart of a medium voltage circuit breaker, SF6-free technology: its electrical performances highly depend upon the vacuum interrupter's characteristics and quality. They must convey and break the rated normal current as well as the rated short circuit one for a number of times specified by the manufacturer.

Brand new design

Schneider Electric has been designing and producing its own vacuum interrupters for 45 years and carries a unique know-how in this field. For the EvoPacT circuit breaker, Schneider Electric has designed a brand new range of vacuum Interrupter, following the very robust process of development: "Model based system engineering". Specific and innovative solutions have been implemented: the VI shape, the contacts shape, the specific barriers to support ceramic protection, the petal shape of the radial magnetic field.

Strict quality controls

The production process includes a total vacuum inside the bottle, high temperature brazing, the use of "getter" material to absorb residual gas and a sealed enclosure. The "anti-twist" feature allows to mount the vacuum interrupter inside the pole of the breaker in an easy way while helping ensure expected performance of the VI.

The new range of VI are then fully compliant with all the main breaker standards as GB/T 1984-2014, DL/T 402- 2016, IEC62271-100, IEEE C37.04-1999 and C37.06-2009.

DM107955

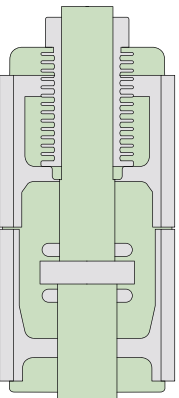

Vacuum interrupters inside principle

Compartments and devices

Operating mechanism safety

Visibility of earthing contacts (option)

The position of main contacts is clearly visible from the front of the cubicle through the window.



Manometer (option)

As well as the SM AirSeT switch being a sealed pressure system, to be completely reassured about the level of the internal pressure we offer an optional analog manometer on the switch.

This device is fitted without any alteration on the switch, it is temperature compensated.



Manometer



High performance operating mechanism

More efficiency with CompoDrive:

- New-generation operating mechanism engineered from high-tech composite for increased endurance
- No-maintenance component-lubricated for life.

Switchgear status indicator:

Fitted directly to the drive shaft, these give a definite indication of the contact's position. (Appendix A of standard IEC 62271-102).

Operating lever:

This is designed with an anti-reflex device that stops any attempt to re-open the device immediately after closing.

Locking device:

Between one and three padlocks enable the following to be locked:

- access to the switching shaft of the switch or the circuit breaker
- access to the switching shaft of the earthing disconnector
- operating of the opening release push-button.

Simple and effortless switching

Mechanical and electrical controls are side by side on the front fascia, on a panel including the schematic diagram indicating the device's status (closed, open, earthed):

- **Closed:** the drive shaft is operated via a quick acting mechanism, independent of the operator. No energy is stored in the switch, except when switching operations are taking place. For combined switch fuses, the opening mechanism is armed at the same time as the contacts are closed.
- **Opening:** the switch is opened using the same quick acting mechanism, operated in the opposite direction. For circuit breakers and the combined switch fuses, opening is controlled by:
 - a push-button
 - a fault.
- **Earthing:** a specific control shaft enables the opening or closing of the earthing contacts. Access to this shaft is blocked by a cover that can be slid back if the switch is open but which remains locked in place if it is closed.

PowerLogic Voltage Detection

PowerLogic Voltage Detection and Indicating System (VDIS) in compliance with IEC 62271-213:2021

- 35 references available to adapt to all applications
- Voltage Output option to provide Voltage signal to Flair 2xD / VD23 or T300 SC150 module through an adapter.

Voltage Output option to provide Voltage signal to Flair 2xD / VD23 or T300 SC150 module through an adapter.

SVI technology at a glance:

- Same operating mode as SF₆ 3-position switch (one operation to break and disconnect, one operation to earth)
- High mechanical endurance: 10 000 CO
- Vacuum technology is well known and proven
- Designed and tested according to standards IEC 62271-103 (switch-disconnector) and IEC 62271-105 (switch-fuse combination)
- Compact and reliable

Main benefits

Advantages: enhanced reliability, reduced maintenance costs

1. Proven vacuum technology and air gap disconnection
2. No toxic by-products generated by current breaking in gas
3. Robust and performing (high mechanical endurance): 10 000 CO operations M2 class according to IEC 62271-103
4. High electrical endurance: 1 000 CO 630 A/24 kV so 10 times E3 class according to IEC 62271-103
5. High breaking capacity enables protection of large distribution transformers with switch-fuse combination
6. Adapted to smart grids with high levels of distributed energy resources and frequent reconfigurations of the network
7. 3-position switch (one operation to break and disconnect, one operation to earth): simple and usual operation, no change of operator habits
8. Shunt Vacuum Interruption (SVI) technology enables switch device to be as compact as the SF₆ version

DM10751



Green SF₆-free MV switchgear technology explained

DM10752



DM10753



Discover Shunt Vacuum Interruption technology

DM10754



Air and vacuum 3-position switch-disconnector

Principle

The principle of the Shunt Vacuum Interruption (SVI) is executed by means of shunting the current through the vacuum interrupter while the disconnector is opening so that the current is interrupted in vacuum.

It is a compact, performing, and tested breaking device for load-break switches and switch-fuse combinations with:

- Breaking by vacuum interrupter.
- Disconnecting in air gap.
- Breaking and disconnecting in one operation as current SF₆ 3-position switch.

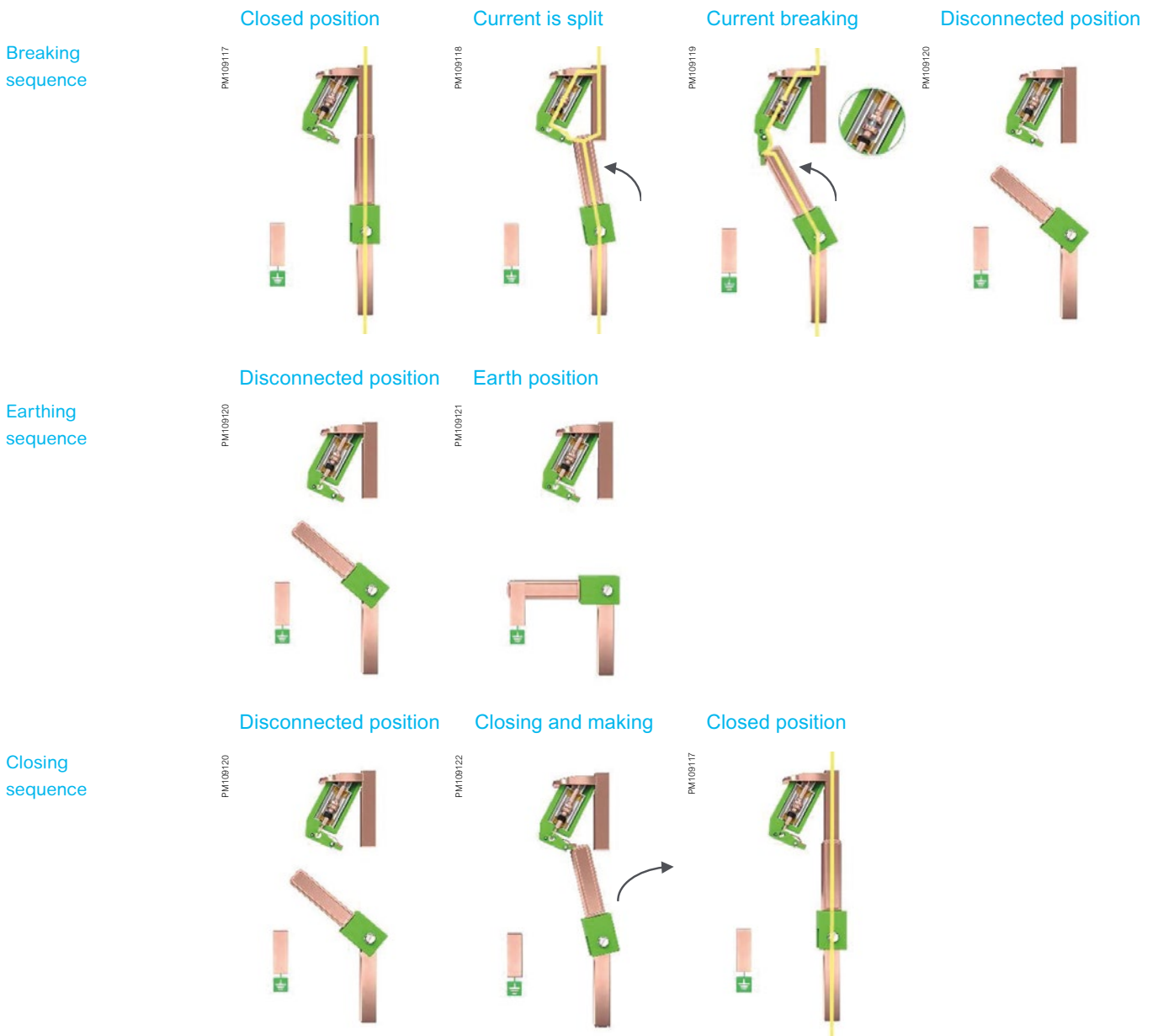

Safety of people

Internal arc protection

Standard IEC 62271-200 Appendix A indicates a method for testing switchgear in metal enclosures under internal arc conditions. The aim of this test is to show that an operator situated in front of a switchboard would be protected against the effects of an internal fault.

To enhance the safety of people, it is desirable to provide as high a degree of protection as possible by evacuating the effects of internal arc using:

- Evacuation systems which direct gases towards the top or the bottom of the switchboard enabling over-pressure to be limited in the case of an internal fault in the compartments
- Channeling and evacuating hot gases towards an external area which is not hazardous for the operator
- Materials which are non-inflammable in the cubicles
- Reinforced panels.

Consequently: The SM AirSeT is designed for enhanced safety

Control of the architecture:

- Compartment type enclosure

Technological control:

- Electrotechnical: modeling of electrical fields
- Mechanical: parts produced using CAD systems

Control of the components' selection:

- Choice of materials
- Earthing switch with closing capacity

Devices for operating safety:

- Voltage presence indicator on the front face
- Intuitive or operator-friendly interlocking
- Locking using keys or padlocks

**SM AirSeT internal arc
(in conformity with IEC 62271-200
appendix A)**

In all internal arc versions, the SM AirSeT has successfully passed all of the type testing relative to standard IEC 62271-200 (5 acceptance criteria). The materials used meet the constraints for which the SM AirSeT is designed. The thermal and mechanical forces that an internal arc can produce are absorbed by the enclosure.

Internal arc withstand

(in conformity with IEC 62271-200)

**4 versions are available
for SM AirSeT**

	Basic	Advance
IAC: A-FL, 12.5 kA 1 s	●	
IAC: A-FLR, 12.5 kA 1 s		●
IAC: A-FL & IAC: A-FLR, 16 kA 1 s		●
IAC: A-FL & IAC: A-FLR, 20 kA 1 s		●

SM AirSeT offers several options to install a standard internal arc withstand switchboard

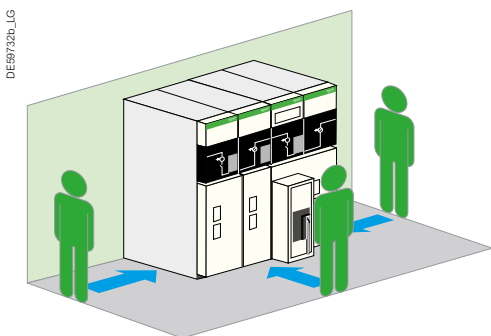

Example of installation of an SM AirSeT switchboard installed against the wall, IAC: A-FL: 3-sides internal arc protection

Basic cubicle

3-sides internal arc protection IAC: A-FL

- 12.5 kA 1s, 16 kA 1s and 20 kA 1s

SM AirSeT switchboard positioned against the wall, access to the rear of the cubicles is impossible, internal arc protection on three sides is sufficient.

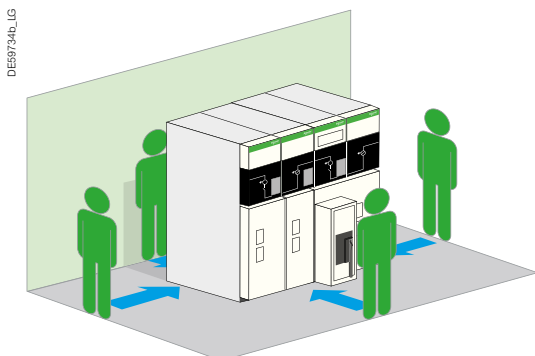

Example of installation of an SM AirSeT switchboard installed in the middle of a room downwards exhaust 16 kA 1s, IAC: A-FLR: 4-sides internal arc protection

Advance cubicle

4-sides internal arc protection IAC: A-FLR

- 12.5 kA 1s, 16 kA 1s and 20 kA 1s

For SM AirSeT switchboards installed in the middle of a room, 4-sides internal arc protection is necessary to help protect an operator moving around the switchboard.

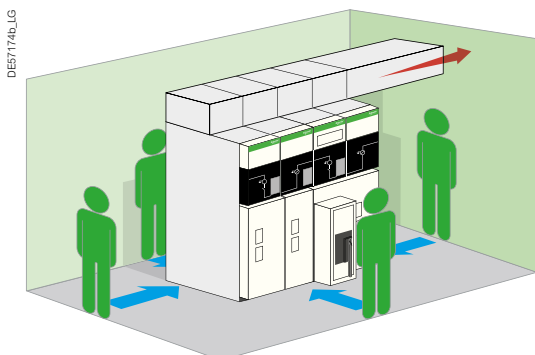

Example of installation of an SM AirSeT switchboard installed in the middle of a room upwards exhaust 12.5, 16 kA 1s and 20 kA 1s, IAC: A-FLR: 4-sides internal arc protection

Advance cubicle

Choice of exhaust (Installation requirements manual to be considered)

- Downwards exhaust
Civil engineering with an adequate volume is necessary.
- Upwards exhaust for SM AirSeT
A ceiling height greater or equal than 2 150 mm is necessary, duct at the right or left side of the cubicle (not supplied).

SM AirSeT meets requirements concerning safety of life and property as well as ease of installation, operation and protecting the environment.

Normal operating conditions

Ambient air temperature:

- Less than or equal to 40 °C
- Less than or equal to 35 °C on average over 24 hours
- Greater or equal to -25 °C

Altitude

- 1 000 m, possible till 3 000 m with impulse withstand voltage and power frequency derating

Solar radiation

- No solar radiation influence is permitted

Ambient air pollution

- No significant pollution by dust, smoke, corrosive and/or flammable gases, vapors or salt

Humidity

- Average relative humidity over a 24 hour period, less than or equal to 95 %
- Average relative humidity over a 1 month period, less than or equal to 90 %
- Average vapor pressure over a 24 hour period, less than or equal to 2.2 kPa
- Average vapor pressure over a 1 month period, less than or equal to 1.8 kPa

For these conditions, condensation may occasionally occur. Condensation can be expected where sudden temperature changes occur in periods of high humidity.

To withstand the effects of high humidity and condensation, such as breakdown of insulation, please pay attention to on Civil Engineering recommendations for design of the building or housing, by suitable ventilation and installation.

Severe operating conditions (please consult us).

PMT11062



- SM AirSeT units are designed for indoor installations.
- Cables are connected via the front.
- All control functions are centralized on a front plate, thus simplifying operation.

The units may be equipped with a number of accessories (relays, toroids, instrument transformers, surge arresters, control and monitoring, etc.).

Compact dimensions make SM AirSeT units easy to install in small rooms and prefabricated substations:

- 375 to 1500 mm width
- 1600 to 2250 mm height
- 840 to 1400 mm depth

Operating conditions and standards

SM AirSeT units meet all the following standards and specifications:

- IEC standards.
- UTE standards.

IEC standards

62271-200	High-voltage switchgear and controlgear - Part 200: A.C. metal-enclosed switchgear and controlgear for rated voltage above 1 kV and up to and including 52 kV.
62271-100	High-voltage switchgear and controlgear - Part 100: Alternating - current circuit breakers.
62271-1	High-voltage switchgear and controlgear - Part 1: Common specifications.
62271-103	High voltage switches - Part 1: switches for rated voltages above 1 kV and less or equal to 52 kV.
62271-105	High-voltage switchgear and controlgear - Part 105: High voltage alternating current switch-fuse combinations.
60255	Electrical relays.
62271-102	High-voltage switchgear and controlgear - Part 102: High-voltage alternating current disconnectors and earthing switches.
61869-2	Instrument transformers - Part 1: Current transformers.
61869-3	Instrument transformers - Part 2: Voltage transformers.
60044-8	Instrument transformers - Part 8: Electronic current transformer.
62271-206	High-voltage prefabricated switchgear and controlgear assemblies - Voltage presence indicating systems.
62271-304	High-voltage switchgear and controlgear - Part 304: Classification of indoor enclosed switchgear and controlgear for rated voltages above 1 kV up to and including 52 kV related to the use in special service conditions with respect to condensation and pollution.

Sustainable Development

Quality, environment and manufacturing certifications

IEC 62474	Material declaration for products of and for the electrotechnical industry.
REACH	REACH compliance (Registration, Evaluation, Authorisation and Restriction of Chemicals) as per European Union regulation EC 1907/2006.
RoHS	RoHS compliance to European Directive RoHS (2002/95/CE) including its addenda in 2008, 201 and 2017 (Restriction of Hazardous Substances in electrical and electronic equipment).
ISO 14040:2006	Including amendments 1 2020: Environmental management - life cycle assessment - Principles and framework.
ISO 14044:2006	Including amendments 1 2017 and 2 2020: Environmental management - life cycle assessment.

UTE standards

NFC 13.200	High voltage electrical installations requirements.
NFC 64.130	High voltage switches for rated voltage above 1 kV and less than 52 kV.
NFC 64.160	Alternating current disconnectors and earthing switches.

Function/module description

Functional units selection	46
Switching	46
Protection switch-fuse	47
Switching automatic Transfer System	48
Protection vacuum type circuit breaker	49
Metering	52
Other functions	53

Functional units selection

Switching

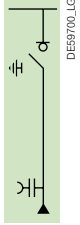
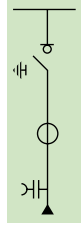
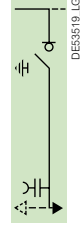
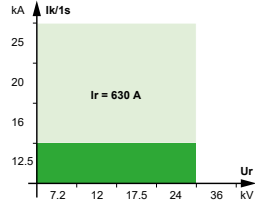
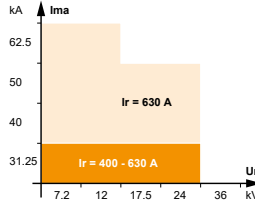

	IM Switch unit 	IMC Switch unit 	IMB Switch unit with earthing switch, right or left outgoing 
Electrical characteristics			
Basic equipment			
Switch and earthing switch	•	•	•
Three-phase busbars	•	•	•
CDT operating mechanism	•	•	•
Voltage presence indicator	•	•	•
LSC2A	•	•	•
Connection pads for dry-type cables	•	•	
Three-phase bottom busbars for outgoing lines			• (right or left)
Current transformers		1 to 3 CTs, for SM AirSeT	
Version			
CD1 operating mechanism ⁽¹⁾	•		•
CD2 operating mechanism ⁽¹⁾	•	•	•
Cubicle options			
Digital ammeter	•		
Surge arresters ⁽²⁾	•		
Ambient monitoring	•		
Earth fault indicators	•	•	
Motor for operating mechanism	•	•	•
Motor with severe and communication	•	•	•
Auxiliary contacts	•	•	•
Key-type interlocks	•	•	•
Release units (coil)	•	•	•
Operation counter	•	•	•
1250 A three-phase upper busbars ⁽¹⁾	•	•	•
630 A three-phase upper busbars for severe operating conditions	•	•	•
Visibility of main contacts (manometer)	•	•	•
Pressure indicator device	•	•	•
Enlarged low-voltage control cabinet	•	•	•
50 W heating element	•	•	•
Arc detection	•	•	•
Thermal monitoring	•	•	•

⁽¹⁾ please consult us

⁽²⁾ in 500 mm width cubicle

Functional units selection

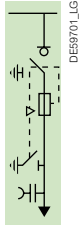
Protection switch-fuse

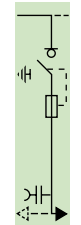
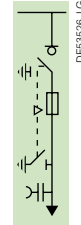
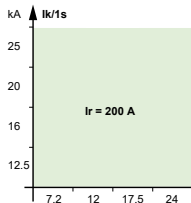
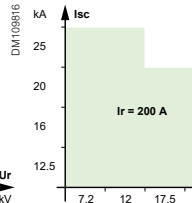
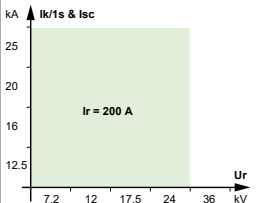
	QM Switch-fuse combination unit 	QMC Switch-fuse combination unit 	QMB Switch-fuse combination unit Outgoing line right or left 	PM Switch-fuse unit 
Electrical characteristics				
	Basic equipment			
	Switch and earthing switch	•	•	•
Three-phase busbars	•	•	•	•
Voltage presence indicator	•	•	•	•
LSC2A	•	•	•	•
Connection pads for dry-type cables	•	•		•
Three-phase bottom busbars for outgoing lines			• (right or left)	
Downstream earthing switch 2 kA rms making capacity	•	•		•
Equipment for three UTE or DIN striker fuses	•	•	•	•
Current transformers		1 to 3 CTs		
Version				
Equipment for three UTE striker fuses	•	•	•	
CDT operating mechanism		•		•
CD1 operating mechanism	•	•	•	•
CD2 operating mechanism	•	•	•	
Cubicle options				
Digital ammeter	•	•	•	•
Motor for operating mechanism	•	•	•	•
Motor with severe and communication	•	•	•	•
Auxiliary contacts	•	•	•	•
Key-type interlocks	•	•	•	•
Auxiliary contact for blown fuses	•	•	•	
Fuses	•	•	•	UTE or DIN striker fuses
Mechanical indication system for blown fuses				•
Release units (coil)	•	•	•	•
1250 A three-phase upper busbars	•	•	•	•
630 A three-phase upper busbars for severe operating conditions	•	•	•	•
Visibility of main contacts (manometer)	•	•	•	•
Pressure indicator device	•	•	•	•
Enlarged low-voltage control cabinet	•	•	•	•
50 W heating element	•	•	•	•
630A cable connection by the top (no internal arc withstand if selected)	•	•	•	•
Key-type interlocks	•	•	•	
Arc detection	•	•	•	•
Ambient monitoring	•			
Thermal monitoring	•	•	•	•

Functional units selection

Switching automatic Transfer System

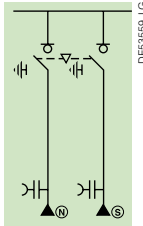
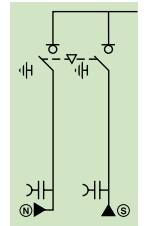
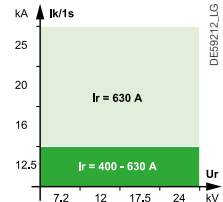
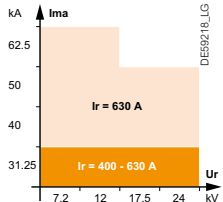
	<p>NSM-cables Cables power supply for main incoming line (N) and standby line (S)</p> 	<p>NSM-busbars Cables power supply for main incoming line on left (N) and busbars for standby line (S) on right</p> 	<p>NSM-busbars Busbars power supply for main incoming line on left (N) and cables for standby line (S) on right</p> 
Electrical characteristics			
Basic equipment	<input checked="" type="checkbox"/>	<input checked="" type="checkbox"/>	<input checked="" type="checkbox"/>
Switch and earthing switch	<input checked="" type="checkbox"/>	<input checked="" type="checkbox"/>	<input checked="" type="checkbox"/>
Three-phase busbars	<input checked="" type="checkbox"/>	<input checked="" type="checkbox"/>	<input checked="" type="checkbox"/>
Voltage presence indicator	<input checked="" type="checkbox"/>	<input checked="" type="checkbox"/>	<input checked="" type="checkbox"/>
Connection pads for dry-type cables	<input checked="" type="checkbox"/>	<input checked="" type="checkbox"/>	<input checked="" type="checkbox"/>
LSC2A	<input checked="" type="checkbox"/>	<input checked="" type="checkbox"/>	<input checked="" type="checkbox"/>
Mechanical interlocking	<input checked="" type="checkbox"/>	<input checked="" type="checkbox"/>	<input checked="" type="checkbox"/>
Motorized operating mechanism CD2 with open/close coils	<input checked="" type="checkbox"/>	<input checked="" type="checkbox"/>	<input checked="" type="checkbox"/>
Additional enclosure	<input checked="" type="checkbox"/>	<input checked="" type="checkbox"/>	<input checked="" type="checkbox"/>
Automatic-control equipment (T300)	<input checked="" type="checkbox"/>	<input checked="" type="checkbox"/>	<input checked="" type="checkbox"/>
Cubicle options	<input checked="" type="checkbox"/>	<input checked="" type="checkbox"/>	<input checked="" type="checkbox"/>
Auxiliary contacts	<input checked="" type="checkbox"/>	<input checked="" type="checkbox"/>	<input checked="" type="checkbox"/>
Key-type interlocks	<input checked="" type="checkbox"/>	<input checked="" type="checkbox"/>	<input checked="" type="checkbox"/>
1250 A three-phase upper busbars	<input checked="" type="checkbox"/>	<input checked="" type="checkbox"/>	<input checked="" type="checkbox"/>
630 A three-phase upper busbars for severe operating conditions	<input checked="" type="checkbox"/>	<input checked="" type="checkbox"/>	<input checked="" type="checkbox"/>
Visibility of main contacts (manometer)	<input checked="" type="checkbox"/>	<input checked="" type="checkbox"/>	<input checked="" type="checkbox"/>
Pressure indicator device	<input checked="" type="checkbox"/>	<input checked="" type="checkbox"/>	<input checked="" type="checkbox"/>
50 W heating element	<input checked="" type="checkbox"/>	<input checked="" type="checkbox"/>	<input checked="" type="checkbox"/>
Key-type interlocks	<input checked="" type="checkbox"/>	<input checked="" type="checkbox"/>	<input checked="" type="checkbox"/>

Functional units selection

Protection vacuum type circuit breaker

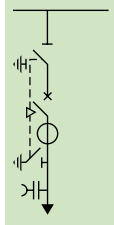
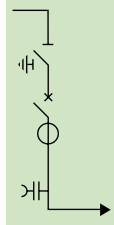
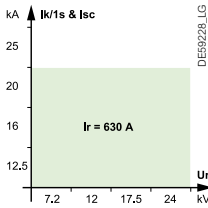
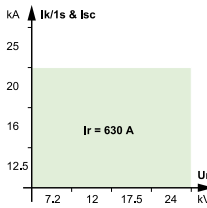
	DMVL-A Single-isolation disconnectable circuit breaker unit	DMVL-D Single-isolation disconnectable circuit breaker unit Outgoing line on right	
			
Electrical characteristics			
Basic equipment	EvoPacT circuit breaker lateral disconnectable	●	●
	Disconnecter and earthing switch	●	●
	Mechanical interlocking between circuit breaker and disconnector	●	●
	Three-phase busbars	●	●
	Circuit breaker operating mechanism	●	●
	Disconnecter operating mechanism CDT	●	●
	Disconnecter operating mechanism CDTs	●	●
	Voltage presence indicator	●	●
	Auxiliary contacts on circuit breaker	●	●
	Current transformers	3 CTs	3 CTs
Connection pads for dry-type cables	●	●	
LSC2A	●	●	
Downstream earthing switch 2 kA rms making capacity	●	●	
Cubicle			
Options	Auxiliary contacts on the disconnector	●	●
	Voltage transformers	3	3
	Key-type interlocks	●	●
	50 W heating element	●	●
	1250 A three-phase upper busbars at I _r 630 A	●	●
	630 A three-phase upper busbars for severe operating conditions	●	●
	Enlarged low-voltage control cabinet	●	●
	PowerLogic Sepam relays	●	●
	PowerLogic P1 relay	●	●
	PowerLogic P3 relay	●	●
	PowerLogic P5 relay	●	●
	Surge arresters	●	●
	Thermal monitoring	●	●
	Arc detection	●	●
	Smart Iso SELPVT1	●	●
Circuit breaker			
Motor for operating mechanism	●	●	
Release units (coil)	●	●	
Operation counter on manual operating mechanism	●	●	

Functional units selection

Protection vacuum type circuit breaker

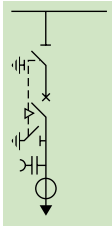
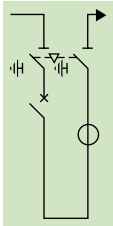
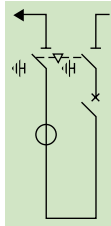
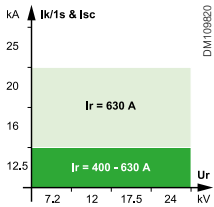
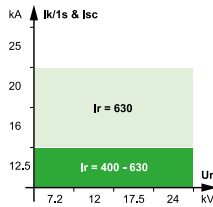
	DMVL-S Single-isolation disconnectable CB unit with independent protection 	DM2 Double-isolation disconnectable CB unit Outgoing line on right 	DM2 Double-isolation disconnectable CB unit Outgoing line on left 
Electrical characteristics			
Basic equipment			
EvoPacT circuit breaker lateral disconnectable	•	•	•
Disconnecter and earthing switch	•	•	•
Three-phase busbars	•	•	•
Circuit breaker operating mechanism	•	•	•
Disconnecter operating mechanism CDT	•	•	•
Disconnecter operating mechanism CDTs	•	•	•
Voltage presence indicator	•		
CTs		3	3
Auxiliary contacts on circuit breaker	•	•	•
Mechanical interlocking between circuit breaker and disconnecter	•	•	•
LSC2A	•	•	•
Connection pads for dry-type cables	•		
Downstream earthing switch 2 kA rms making	•		
VIP relay	•		
Three CR sensors for VIP relay protection	•		
Options			
Cubicle			
Arc detection		•	
Thermal monitoring	•	•	•
630 A busbars earthing switch cabinet (not available for internal arc IEC 62271-200)	•	•	
Ambient monitoring	•		
Auxiliary contacts on the disconnecter		•	•
Protection		PowerLogic Sepam & PowerLogic P1, P3 & P5 relay programmable electronic units	
Voltage transformers		2 VTs phase-to-phase OR 3 VTs phase-to-earth	
Key-type interlocks	•	•	•
1250 A three-phase upper busbars at Ir 630 A	•	•	•
630 A cable connection by the top (no internal arc withstand if selected)	•	•	•
630 A three-phase upper busbars for severe operating conditions	•	•	•
Enlarged low-voltage control cabinet	•	•	•
50 W heating element	•	•	•
Smart Iso SELPVTA1	•	•	•
Circuit breaker			
Motor for operating mechanism	•	•	•
Release units (coil)	•	•	•
Operation counter on manual operating mechanism	•	•	•

Functional units selection

Protection vacuum type circuit breaker

DMVL-M

Single-isolation, disconnectable CB and measurement unit. Outgoing line on right

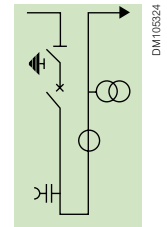

Electrical characteristics

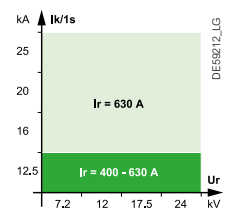

Basic equipment	EvoPacT circuit breaker lateral disconnectable	•
	Disconnecter and earthing switch	•
	Three-phase busbars	•
	Circuit breaker operating mechanism	•
	Disconnecter operating mechanism CDT	•
	Disconnecter operating mechanism CDTs	•
	Voltage presence indicator	•
	Current transformers	Please consult us
	Auxiliary contacts on circuit breaker	•
	Mechanical interlocking between circuit breaker and disconnecter	•
	LSC2A	•
	Connection pads for dry-type cables	•
Equipment for three UTE or DIN striker fuses	•	
Version		
Cubicle options	Smart Iso SELPVT1	•
	Arc detection	•
	Thermal monitoring	•

Functional units selection

Metering

	CM Voltage transformers unit for network with earthed neutral system 	CM2 Voltage transformers unit for network with insulated neutral system 	GBC-A Current and/or voltage measurements unit Outgoing line on right 	GBC-A Current and/or voltage measurements unit Outgoing line on left 	GBC-B Current and/or voltage measurements unit 	
Electrical characteristics						
Basic equipment	Disconnector and earthing switch	•	•			
	Three-phase busbars	•	•	•	•	
	Operating mechanism CDT	•	•			
	LV circuit isolation switch	•	•			
	LV fuses	•	•			
	6.3 A UTE or DIN type fuses	3	3			
	LSC2A	•	•			
LSC1			•	•	•	
Voltage transformers	3 VTs (phase-to-earth)	2 VTs (phase-to-phase)				
Current transformers			1 to 3 CTs	1 to 3 CTs	1 to 3 CTs	
Connection bars			•	•	•	
Options	Cubicle					
	Auxiliary contacts	•	•			
	Mechanical signaling for blown fuses	•	•			
	Auxiliary contact for blown fuses	2	2			
	1250 A three-phase upper busbars	•	•	•	•	•
	630 A cable connection by the top (no internal arc withstand if selected)	•	•	•	•	
	50 W heating element	•	•	•	•	•
	630 A three-phase upper busbars for severe operating conditions	•	•	•	•	•
	Enlarged low-voltage control cabinet	•	•	•	•	•
	Voltage transformers			3 VTs (phase-to-earth) / 2 VTs (phase-to-phase)		
Arc detection	•	•	•	•		

Functional units selection

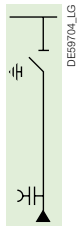
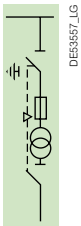
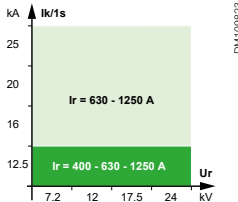
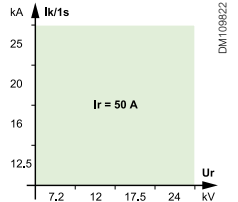

Other functions

	GBM Connection unit Outgoing line right or left 	GIM Intermediate bus unit 	GAM2 Incoming-cable-connection unit 
Electrical characteristics			
Basic equipment	<ul style="list-style-type: none"> Three-phase busbars with outgoing right or left 		<ul style="list-style-type: none"> Three-phase busbars with outgoing right or left
			<ul style="list-style-type: none"> Voltage presence indicator
			<ul style="list-style-type: none"> Connection pads for dry-type cables
	<ul style="list-style-type: none"> Connection bars 		<ul style="list-style-type: none"> Connection bars
	<ul style="list-style-type: none"> LSC1 		<ul style="list-style-type: none"> LSC1
		<ul style="list-style-type: none"> Metallic envelope 	
Options			<ul style="list-style-type: none"> Earth fault indicator
			<ul style="list-style-type: none"> Digital ammeter
	<ul style="list-style-type: none"> 1250 A three-phase upper busbars at Ir 630 A 		<ul style="list-style-type: none"> 1250 A three-phase upper busbars at Ir 630 A
	<ul style="list-style-type: none"> Enlarged low-voltage control cabinet 		<ul style="list-style-type: none"> Enlarged low-voltage control cabinet
	<ul style="list-style-type: none"> 630A cable connection by the top (no internal arc withstand if selected) 		<ul style="list-style-type: none"> 630A cable connection by the top (no internal arc withstand if selected)
	<ul style="list-style-type: none"> 50 W heating element 		<ul style="list-style-type: none"> 50 W heating element
	<ul style="list-style-type: none"> Arc detection 		<ul style="list-style-type: none"> Arc detection
	<ul style="list-style-type: none"> Thermal monitoring 		<ul style="list-style-type: none"> Thermal monitoring

	SM Disconnector unit 	TM MV/LV transformer unit for auxiliaries 
Electrical characteristics		
Basic equipment	•	•
Three-phase busbars	•	•
Disconnector and earthing switch	•	•
Voltage presence indicator	•	•
Connection pads for dry-type cables	•	•
LSC2A	•	•
Fuses	•	Two 6.3 A fuses, UTE or DIN type
LV circuit isolating switch	•	•
Voltage transformer	•	1 Phase-to-phase VT
Operating mechanism CDT	•	•
Options	•	•
Digital ammeter	•	•
1250 A three-phase upper busbars at Ir 630 A	•	•
630 A three-phase upper busbars for severe operating conditions	•	•
Enlarged low-voltage control cabinet	•	•
630 A cable connection by the top (no internal arc withstand if selected)	•	•
50 W heating element	•	•
Arc detection	•	•
Thermal monitoring	•	•
Surge arresters	•	•
Auxiliary contacts	•	•
Auxiliary contact for blown fuses	•	•
Mechanical signalling for blown fuses	•	•
Key-type interlocks	•	•

Components and accessories

Operating mechanisms	56
Auxiliaries	61
Current transformers	62
Voltage transformers	64
Low Power Current & Voltage transformers	66
Protection of transformers	67
Transformer protection by switch-fuses	67
Interlocks	69
Protection	72
PowerLogic™ P1 relay	72
PowerLogic™ P3 relay	73
PowerLogic™ P5 relay	76
Easergy Sepam	75
Protection and sensor selection table	76
LPCT protection chain	77
LPVT protection chain	78
Fault passage indicators	79
Flair 21D, 22D and 23DM	79
Ammeter	82
Protection	83
PowerLogic™ A1 & A3 relay	83
Control	84
Motorization control	84
Monitoring & control	85
PowerLogic Thermal Sensor TH110	85
Wireless Environmental Monitoring PowerLogic CL110	86
PowerLogic T300 S	87
PowerLogic T300 I	88
PowerLogic T300 Automation systems	89
PowerLogic T300 Condition monitoring	96
PS100 high-availability power supply	97

			CompoDrive				
			Type	CDT	CDTS	CD1	CD2
			Principle	Tumbler (1)	Tumbler (1)	1 latching (2)	2 latching
Common Application							
Switch - IEC 62271-102 & 103				●	-	●	●
Switch-fuse: Transformer protection with combination IEC 62271-105				-	-	●	●
Disconnecter (breaking by circuit breaker) - IEC 62271-102				-	●	-	-
Operation mode	Operating lever			●	●	●	●
	Mechanical push buttons	One button		-	-	●	-
		Two buttons		○	-	○	○
Motor availability				○	-	○	○
Coils availability			Opening/Tripping coil	-	-	●	●
			Closing coil	-	-	-	●
Auxiliary contacts			Disconnecter: 2 NO/NC	E/S: 1 NO/NC	○	○	○
			Disconnecter: 5 NO/NC	E/S: 2 NO/NC	○	○	○
			Fuse blow:	2 NO/NC	-	-	○

(1) For several decades, the tumbler principle has become the preferred technology for robust and demanding 3 position mechanisms.

When the operator turns the lever, the first part of the movement loads the springs; once a middle-point is passed, the energy stored in the springs is immediately released. Opening or closing of contacts is independent of the speed of the lever.

Alternatively, a motor can operate the tumbler in the same way: the speed of the opening/closing of the main contacts remain independent of the motor gear.

(2) Latching system: a spring with latching allows fast closing and opening for some applications:

- 1 latching is required for fuse switches opening in the case of fuse melt (the fuse stricker releases the latching for opening).
- For faster transfer (ATS), a mechanism with 2 latching (CD2) is recommended.

Legend: ● Available / ○ Option / - Not Available

Units	Type of operating mechanism			
	CDT	CD1*	CD2	CDTS
IM, IMB, IMM	●	○	○	-
IMC	●	○	○	-
PM	●	-	-	-
QM	-	○	●	-
QMC, QMB	-	○	●	-
CM, CM2	●	-	-	-
DMVL-A, DMVL-S	-	-	-	●
DMVL-D, DM2	●	-	-	-
NSM cables, NSM busbars	-	-	●	-
SM, TM	●	-	-	-

Units	Line switch		Earth switch
	Manual	Motorized*	Manual
CDT	10 000 op.	3 000 op.	2 000 op.
CDTS	1 000 op.	-	1 000 op.
CD2	5 000 op.	3 000 op.	2 000 op.
CD1	5 000 op.	3 000 op.	2 000 op.

(*) CD1 not yet available

PM109185



Digital ready: customize when you want, in a few minutes

Operating mechanisms for Disconnect – Switch and of Circuit Breaker offer an unprecedented, consistent set of accessories than can easily be added after delivery from the Schneider Electric plant.

The kits are prepared and available: the references can be found on the Schneider Electric website www.se.com or from Schneider Electric partners. The literature, plus adaptation support tools allow a more open adaptation by the customer, the contractor, or Schneider Electric partners.

PM108716

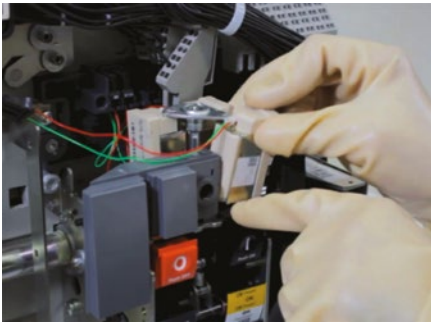

These kits are supported by a set of videos to help install and upgrade further:

- Available by flashing the QR code on the switchgear.
- Or at www.se.com.

Example: 'how to video' demonstrating the adaptation of the opening coil on the circuit breaker mechanism.

- ("How-to-Video" available at youtube).

[Upgrade from Manual to Motorized Operation](#)



PM109141

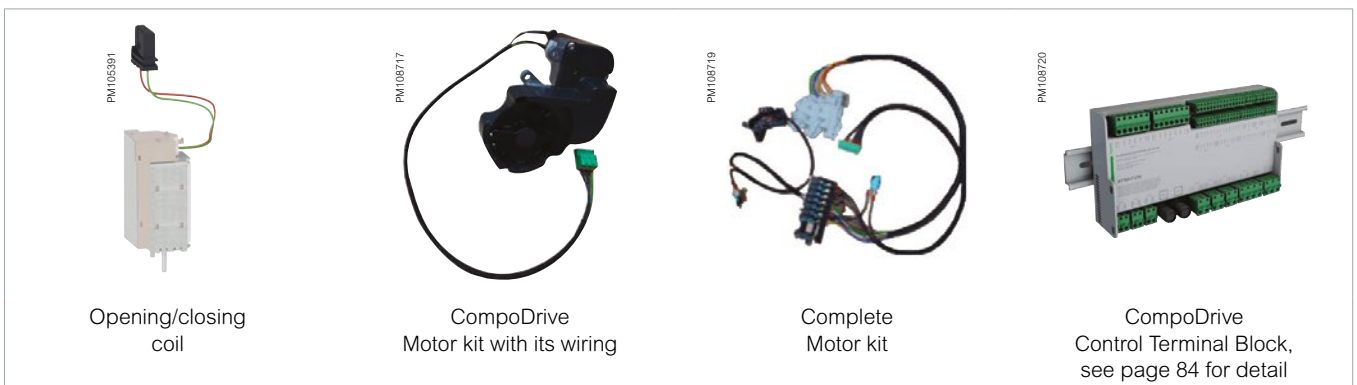

PM109167



CompoDrive: Adapted to the cases of secondary distribution

SM AirSeT offers three types of CompoDrive operating mechanisms - one per type of application:

- Tumbler mechanisms: opening / closing time are independent of the lever speed or the operator
 - Without latching: CDT
CDTS (applicable for downstream Earth Switch operation)
 - With 1 latching systems: CD1
 - With 2 latching systems: CD2.

(Spring with latching allows faster closing and opening for some applications: mostly fuse switches, ATS).

PM109163

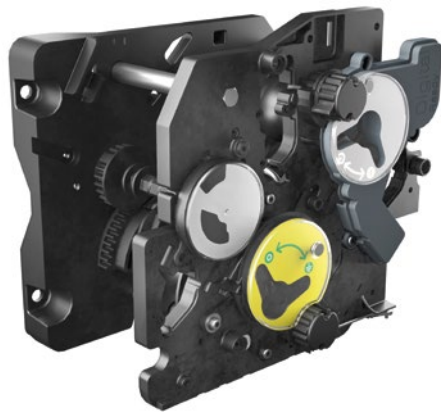

Double-function operating mechanism CDT

Switch function

Operation-independent opening or closing by lever or motor.

Switch and earthing switch functions

Dependent-operation opening and closing by lever.

Earthing switch function

- Operation-independent opening or closing by lever.
- Operating energy is provided by a compressed spring which, when released, causes the contacts to open or close.

PM109163

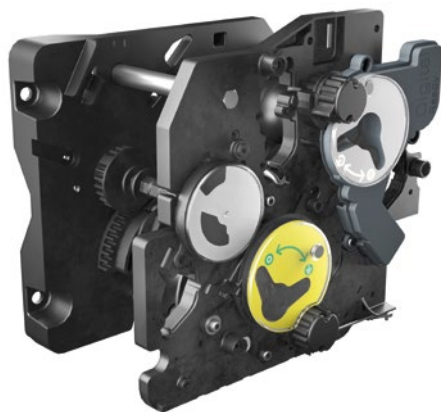

Double-function operating mechanism CDTS

Switch function

Operation-independent opening or closing by lever.

Switch and earthing switch functions

Dependent-operation opening and closing by lever.

Earthing switch function

- Operation-independent opening or closing by lever.
- Operating energy is provided by a compressed spring which, when released, causes the contacts to open or close.
- Operation of downstream earthing switch.

PM109175



Double-function operating mechanism CD1

Switch function

Operation-independent opening or closing by lever or motor.

- Operation-independent opening by pushbutton (O) or electrical release. Operating energy is provided by a compressed spring which, when released, causes the contacts to open or close.

Earthing switch function

- Operation-independent opening or closing by lever. Operating energy is provided by a compressed spring which, when released, causes the contacts to open or close.

PM109172



Double-function operating mechanism CD2

Switch function

- Operation-independent closing in two steps:
 - 1 – Operating mechanism recharging by lever or motor
 - 2 – Stored energy released by pushbutton (I) or electrical release.
- Operation-independent opening by pushbutton (O) or electrical release.

Earthing switch function

- Operation-independent opening or closing by lever. Operating energy is provided by a compressed spring which, when released, causes the contacts to open or close.

PM111095

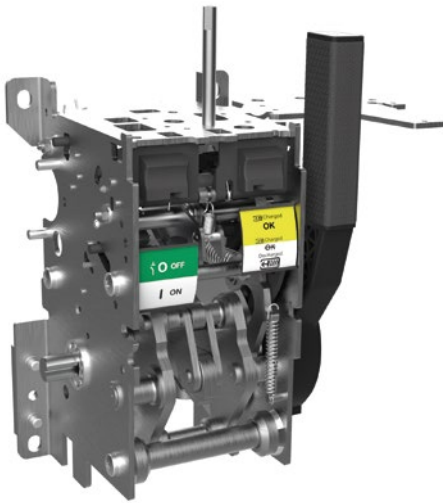

Operating mechanism of EvoPacT lateral vacuum circuit breaker

Circuit-breaker function

- An evolution of proven mechanisms from Schneider Electric benefiting from decades of experience in Medium Voltage Circuit Breakers.
- Springs store the energy to fast open-trip, and fast close.
- Local / Manual controls
- **2 push buttons** at front for manual opening and closing orders
- **Mechanical indicators** (spring "charged" / "discharged" – device "open" / "closed")
- **Built-in lever** for manual loading (no additional tool is required)
- **Operation counter**
- The controls easily accessible.

Electric motor

- Electric motor (MCH).

Closing releases

- Shunt trip (XF).

Opening releases

- Shunt trip (MX1, MX2).
- Undervoltage (MN).
- Low energy (MITOP).

Auxiliary contacts

- Circuit breaker (8O+ 8C).
- Mechanism charged (1NO+1NC).

The table below shows the possible configurations for electrical control of the device.

Combination	Charging device	Closing release	Opening releases			
	MCH	XF	MX1	MX2	MN	MITOP
1	•	•	•			
2	•	•	•	•		
3	•	•	•		•	
4	•	•	•			•
5	•	•	•	•		•
6	•	•	•		•	•

PM1109168

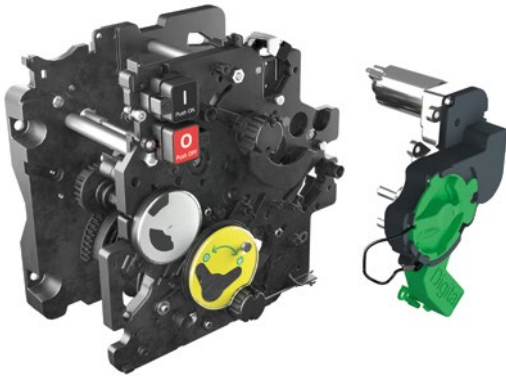

Motor option and releases for switch-units

The operating mechanisms CDT, CD1 and CD2 may be motorized.

Un		DC					AC (50 Hz)*	
Power supply	(V)	24	48	110	125	220	120	230
Motor option								
	(W)	200						
	(VA)						200	
CDT, CD1, CD2		≤ 10 (s)					≤ 10 (s)	
Opening releases								
Shunt trip	(W)	200	250	300	300	300		
	(VA)						400	750
Response time (ms)								
	CD1	100					100	
	CD2	100					100	
Undervoltage for CD1, CD2								
Pick-up		(W)	160					
	(VA)						280	550
Hold		(W)	4					
	(VA)						50	40
Response time (ms)								
	CD1	45					45	
	CD2	83					53	
	CD2	83					46	
Closing release								
Shunt trip	(W)	200	250	300	300	300		
	(VA)						400	750
Response time (ms)								
	CD2	100					100	

* Please consult us for other frequencies.

PM111095

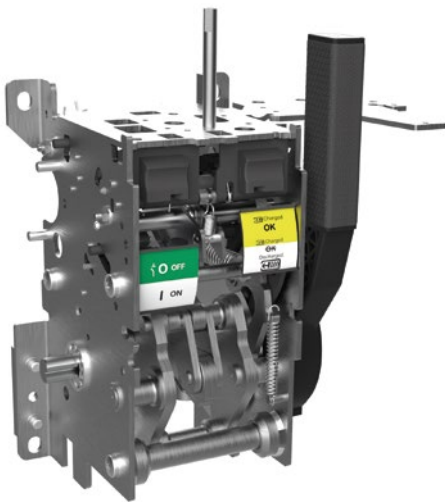

Motor option and releases for EvoPacT 24 kV lateral vacuum circuit breaker

Operating mechanism may be equipped with the motor option for the recharging function.

Un		DC				AC	
Power supply	(V)	24-30	48-60	100-125	200-250	100-130	200-250
Motor option							
Reference		47888	47889	47890	47891	47893	47894
	(W)	-			180		
	(VA)	-			180		
Charging time (s)		4~12					
Opening/ closing coil							
Reference		33659	33660	33661	33662	33661	33662
	(W)	200					
	(VA)	200					
Response time (ms)		200					
Undervoltage coil							
Reference		33668	33669	33670	33671	33670	33671
Pick-up		(W)	200				
	(VA)	200					
Hold		W	4.5				
	VA	4.5					
Response time		ms	200				
Mitop (low energy)							
Reference		RMU-MITOP-VIP					
	(W)	2					
Response time (ms)		30					

Synthesis table by unit

	CT References	QMC	DMVL - A DMVL - D DMVL - M	DM2	GBC - A GBC - B	IMC	DMVL - A DMVL - D
TC	SE CT M A1		•	•	•		
	SE CT M A2	•					
	SE CT M A3					•	
	SE CT M A4						•
	SELPCT RA1						

PM109137



SE CT M A1

Transformer SE CT M A1 - 50 or 60 Hz

- Characteristics according to standard IEC 61869-2
- Double primary winding
- Double secondary winding for measurement and protection

Short-time withstand current I_{th} (kA)

Insulation level (kV)	24/50/125					
I _{1n} (A)	10/20	15/30	20/40	25/50	50/100	
I _{th} (kA)	5/10	8/16	12.5/25		21	14.5/29
t (s)	1		0.8		1	
1 st secondary 5 A (measurement)	7.5 VA - cl 0.5 Fs10		15 VA - cl 0.5 Fs10		7.5 VA - cl 0.5 Fs10	30 VA - cl 0.5 Fs10
2 nd secondary 1 A (protection)	1 VA - 10P30		1 VA - 10P30		1 VA - 10P30	
2 nd secondary 5 A (protection)	5 VA - 5P10				2 VA - 5P30 5 VA - 5P15	5 VA - 5P15 7.5 VA - 5P10

Insulation level (kV)	24/50/125									
I _{1n} (A)	75/150		100/200		200/400			300/600		
I _{th} (kA)	25	16/32	25	16/32	12.5/25	25 kA x 1 s 20 kA x 2 s	25	12.5/25	25 kA x 1 s 20 kA x 2 s	25
t (s)	1									
1 st secondary 5 A (measurement)	7.5 VA - cl 0.5 Fs10	30 VA - cl 0.5 Fs10	7.5 VA - cl 0.5 Fs10	30 VA - cl 0.5 Fs10	7.5 VA - cl 0.5 Fs10		30 VA - cl 0.5 Fs10	7.5 VA - cl 0.5 Fs10		30 VA - cl 0.5 Fs10
2 nd secondary 1 A (protection)	-				1 VA - 10P30	-			1 VA - 10P30	-
2 nd secondary 5 A (protection)	2.5 VA - 5P30 5 VA - 5P15	5 VA - 5P15 7.5 VA - 5P10	2 VA - 5P30 5 VA - 5P15	15 VA - 5P10 7.5 VA - 5P15	-	2 VA - 5P10 5 VA - 5P15	15 VA - 5P10 7.5 VA - 5P15	-	1 VA - 5P30 5 VA - 5P15	15 VA - 5P10 7.5 VA - 5P15

PM109136



SE CT M A2

Transformer SE CT M A2 - 50 or 60 Hz

- Characteristics according to standard IEC 61869-2
- Single primary winding
- Double secondary winding for measurement and protection

Insulation level (kV)	24/50/125					
I _{1n} (A)	20	30	50	100	150	200
I _{th} (kA)	2.4	3.6	6	10	10	10
t (s)	1					
1 st secondary 5 A (measurement)	15 VA - cl 0.5 Fs10					
2 nd secondary 5 A (protection)	2.5 VA - 5P20					

PM109136



SE CT M A3

Transformer SE CT M A3 - 50 or 60 Hz

- Characteristics according to standard IEC 61869-2
- Single primary winding
- Double secondary winding for measurement and protection

Insulation level (kV)	24/50/125					
I _{1n} (A)	50	100	200	400	600	
I _{th} (kA)	10	25				
t (s)	1					
1 st secondary 5 A (measurement)	7.5 VA - cl 0.5 Fs10	10 VA - cl 0.5 Fs10	15 VA - cl 0.5 Fs10			20 VA - cl 0.5 Fs10
2 nd secondary 5 A (protection)	5 VA - 5P10	2.5 VA - 5P20	5 VA - 5P20	5 VA - 5P20	7.5 VA - 5P20	

PM109139



SE CT M A4

Transformer SE CT M A4 - 50 or 60 Hz

- Characteristics according to standard IEC 61869-2
- Single primary winding
- Double secondary winding for measurement and protection

Insulation level (kV)	24/50/125			
I _{1n} (A)	1000		1250	
I _{th} (kA)	25			
t (s)	1			
1 st secondary 1 A (measurement)	30 VA - cl 0.5 Fs10	-	30 VA - cl 0.5 Fs10	-
1 st secondary 5 A (protection)	-	30 VA - cl 0.5 Fs10	-	30 VA - cl 0.5 Fs10
2 nd secondary 1 A (measurement)	10 VA - 5P20	-	10 VA - 5P20	-
2 nd secondary 5 A (protection)	-	10 VA - 5P20	-	10 VA - 5P20

Synthesis table by unit

		Units					
		CM	GBC-A	GBC-B	DMVL-A, DMVL-D	CM2	DM2
VTs, SE LPVT A1	SE VT PE A1	•	•	•			
	SE VT PE A2				•		•
	SE VT PP A1		•	•		•	

PM109123



VFC21

Transformer SE VT PE A1/SE VT PE A2 (phase-to-earth) 50 or 60 Hz

- Characteristics according to standard IEC 61869-3.

Single metering secondary

Insulation level (kV)	24/50/125		17.5/38/95		12/28/75	7.2/20/60
Primary voltage (kV)	20.0/√3 - 15.0/√3		15.4/√3	12.1/√3	11.0/√3	6.6/√3
Secondary voltage (V)	100/√3		110/√3			
Rated burden	15 VA @ 20 kV 10 VA @ 15 kV	15 VA @ 20 kV 15 VA @ 15 kV	5 VA - 15 VA			
Accuracy class	cl 0.5		cl 0.2			

Double metering secondary

		50-60			60	50-60					
		24/50/125			17.5/38/95		12/28/75				
1 st metering secondary	Primary voltage (kV)	20.0/√3 - 15.0/√3		20.0/√3	15.0/√3	13.8/√3	11.0/√3	10.0/√3			
	Secondary voltage (V)	100/√3		100/√3	100/√3	120/√3	110/√3	100/√3			
	Rated burden	15 VA @ 20 kV 15 VA @ 15 kV		10 VA	15 VA - 30 VA	10 VA	15 VA - 30 VA	10 VA	10 VA	10 VA	15 VA - 30 VA
	Accuracy class	15 VA - 30 VA		cl 0.2	cl 0.5	cl 0.2	cl 0.5	cl 0.2	cl 0.2	cl 0.2	cl 0.5
2 nd metering secondary	Secondary voltage (V)	100/√3		100/√3	100/√3	120/√3	110/√3	100/√3			
	Rated burden	15 VA @ 20 kV 15 VA @ 15 kV		10 VA	15 VA - 30 VA	10 VA	15 VA - 30 VA	10 VA	10 VA	10 VA	15 VA - 30 VA
	Accuracy class	cl 0.5		cl 0.2	cl 0.5	cl 0.2	cl 0.5	cl 0.2	cl 0.2	cl 0.2	cl 0.5

Double secondary metering and protection

Double metering secondary

		50-60				60	50-60								
		24/50/125				17.5/38/95		12/28/75				7.2/20/60			
1 st metering secondary	Primary voltage (kV)	22.0/√3		20.0/√3	15.0/√3	13.8/√3	11.0/√3	10.0/√3	6.6/√3	6.3/√3	6.0/√3	5.5/√3	3.3/√3	3.0/√3	
	Secondary voltage (V)	110/√3		100/√3	100/√3	120/√3	110/√3	100/√3	110/√3	100/√3	100/√3	110/√3	110/√3	100/√3	
	Rated burden	10 VA	20 VA	10 VA	20 VA	20 VA	20 VA	10 VA	20 VA	20 VA	20 VA	20 VA	10 VA	20 VA	20 VA
	Accuracy class	cl 0.2	cl 0.5	cl 0.2	cl 0.5	cl 0.5	cl 0.5	cl 0.2	cl 0.5	cl 0.5	cl 0.5	cl 0.5	cl 0.2	cl 0.5	cl 0.5
2 nd metering secondary	Secondary voltage (V)	110/3		100/3	100/3	120/3	110/3	110/3	100/3	110/3	100/3	100/3	110/3	110/3	100/3
	Rated burden	50 VA													
	Accuracy class	cl 3P													

PM109124



VDC21

Transformer SE VT PP A1 (phase-to-phase) 50 or 60 Hz

- Characteristics according to standard IEC 61869-3.

Insulation level (kV)	12/28/75	17.5/38/95	24/50/125
Primary voltage (kV)	10	15	20
Secondary voltage (V)	100		
Accuracy class	cl 0.5		
Rated output for single primary winding (VA)	50		

PM111096



Surge arresters

For units IM500, DMVL-A

In (A)	400/630				
Un (kV)	7.2	10	12	17.5	24

Note: The rated voltage of the surge arrester is according to unit's rated voltage.

Low Power Current & Voltage transformers

FE57162



Low Power Current Transformer (LPCT) SE LPCT A1

- Characteristics according to standard IEC 61869-10
- Large primary current range
- Direct output voltage for measurement and protection
- RJ45-8 pts secondary connector
- Insulation level 0.72 kV
- Internal diameter 130 mm

Minimum rated primary current	5 A
Rated nominal primary current	100 A
Rated extended primary current	1250 A
Rated nominal secondary output	22.5 mV
Accuracy class for measurement	0.5
Accuracy class for protection	5P
Accuracy limit factor	250
Rated short time thermal current	25 kA 1 s
Highest voltage (Um)	0.72 kV
Rated power-frequency withstand	3 kV

PM109125



Low Power Voltage Transformer SE LPVT A1

Compact high accuracy Low Power Voltage Transformers (LPVT), complies with international standard IEC 61869-11.

The LPVT is based on the capacitive divider principle and the voltage output is proportional to the MV network voltage.

The linearity and high accuracy are delivered in the whole operating range and allow the combination of metering and protection classes in one LPVT.

These innovative LPVTs are ideal for the new generation of electronic protection devices such as PowerLogic P3 and PowerLogic P5 relays (not with Sepam relay) helping ensure:

- Large primary voltage range, low power consumption and reduced size
- Direct output voltage for measurement and protection
- RJ45-8 pts secondary connector
- Excellent accuracy for harmonic measurement allowing Quality Metering
- Reliability with LPVT ferroresonance free.

DM110116

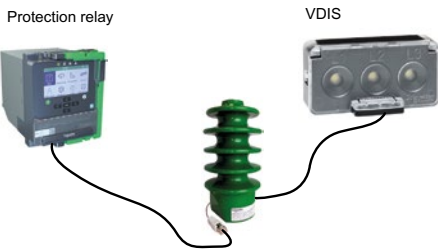

LPVT connected to protection relay for circuit-breaker

Insulation level (Um)	24/50/125 kV
Rated primary voltage (Upr)	20: $\sqrt{3}$ kV
Rated secondary voltage (U _{sr})	3.25: $\sqrt{3}$ V
Range of primary voltage (U _{pmin} - U _{pmax})	5: $\sqrt{3}$ kV to 23: $\sqrt{3}$ kV
Burden	10 M Ω 75pF
Accuracy class	0.5 P
Accuracy for harmonics	Quality metering
Voltage factor (Fv)	1.2 contin. - 1.9 U _p x 8h
Rated frequency	50 - 60 Hz

Protection of transformers

Transformer protection by switch-fuses

Fuse ratings for SM AirSeT protection units such as PM, QM, QMB and QMC depend, among other things, on the following criteria:

- Service voltage
- Transformer rating
- Fuse technology (manufacturer).

Different types of fuses with medium loaded striker may be installed:

- **Solefuse** fuses as per standard UTE NCF 64.210
- **Fusarc CF** fuses as per standard IEC 62271-105 recommendation and dimensions are related to DIN 43.625 (Ucc acc. IEC 60076-5).

For switch-fuse combination unit type QM, QMB, QMC, refer only to the selection table and reference list of fuses. For all other type of fuses, consult us.



⚠ Please consult us for overloads and operation over 40 °C for France Transfo oil immersed type transformers.

Fuse selection table

The color code is linked to the rated voltage of the fuse
Rating in A - no overload at -5 °C < t < 40 °C, ≤1000 m altitude.

Solefuse (general case, UTE NFC standard 13.200)																
Rated voltage	U _s (kV)	S _r (kVA)														
		25	50	100	125	160	200	250	315	400	500	630	800	1000	1250	1600
7.2 kV	3.3	6.3	16	31.5	43	43	63	63								
	5.5		10		25	31.5	31.5	43	63	63						
12 kV	6.6		10	16		25	31.5	43	43	63				125 (1,2)		
	10			16	16	16	25	31.5	31.5	43	63	63				
24 kV	13.8			6.3	10	16	16	25	25	31.5	31.5	43				
	15			6.3	10	10		25	25	25	31.5	43	43	63		
	20					10	10	16	16	25	25	31.5	31.5	43	63	
	22					6.3	10	16	16		25	25	31.5	43		

Fusarc CF and SIBA (general case for QM, QMB and QMC cubicle according to IEC 62271-105)																		
Rated voltage	U _s (kV)	S _r (kVA)																
		25	50	100	125	160	200	250	315	400	500	630	800	1000	1250	1600	2000	2500
7.2 kV 292 mm (3)	3	16	25	40	50	50	63	80	100	125 ⁽⁴⁾	160 ⁽⁴⁾	160 ^(1,4)						
	3.3	10	25	40	40	50	63	80	100	125 ⁽⁴⁾	160 ⁽⁴⁾	160 ^(1,4)						
	5	6.3	16	31.5	31.5	40	50	50	63	80	100	125 ⁽⁴⁾	160 ⁽⁴⁾	160 ^(1,4)				
	5.5	6.3	16	25	31.5	40	40	50	63	80	100	125 ⁽⁴⁾	125 ⁽⁴⁾	160 ^(1,4)				
	6	6.3	16	25	31.5	31.5	40	50	63	63	80	100	125 ⁽⁴⁾	160 ⁽⁴⁾	160 ^(1,4)			
12 kV 292 mm (3)	6.6	6.3	10	25	25	31.5	40	50	50	63	80	100	125 ⁽⁴⁾	160 ⁽⁴⁾	160 ^(1,4)			
	10	6.3	6.3	16	20	25	31.5	31.5	40	50	63	63	80	100 ⁽⁴⁾	125 ⁽⁴⁾			
24 kV 442 mm (3)	11	6.3	6.3	16	20	25	25	31.5	40	50	50	63	80	100 ⁽¹⁾	125 ^(1,4,6)	160 ^(1,4,6)		
	13.8	4	6.3	10	16	20	25	25	31.5	40	50	50	63	80	100 ⁽¹⁾	100 ⁽¹⁾		
	15	4	6.3	10	16	20	20	25	31.5	40	40	50	50	80	80	100 ⁽¹⁾	125 ^(1,4)	
	20	4	6.3	6.3	10	16	16	20	25	31.5	40	40	40	50	63	80	100	
	22	4	6.3	6.3	10	16	16	20	25	25	31.5	40	40	50	50	63 ⁽¹⁾	80 ⁽¹⁾	100 ⁽¹⁾

(1) Without overload

(2) Switch-fuse transf.current limitation

(3) Length of fuse

(4) SIBA std

(5) SIBA SSK

(6) Use the 12 kV fuse for 24 kV application

Protection of transformers

Transformer protection by switch-fuses

Fuses dimensions

Solefuse (UTE standards)



Ur (kV)	Ir (A)	L (mm)	Ø (mm)	Weight (kg)
7.2	63-125	520	55	2.3
7.2/12	100	520	55	2.3
7.2/17.5	80	520	55	2.3
12/24	6.3-63	520	55	2.3

Fusarc CF (DIN standards)

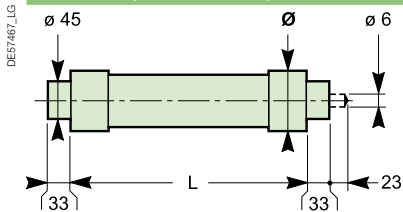

Ur (kV)	Ir (A)	L (mm)	Ø (mm)	Weight (kg)
3.6	250	292	86	3.4
7.2	4-40	192	50.5	1.0
	50-100	192	76	2.1
	6.3-40	292	50.5	1.2
	50-100	292	76	3.2
	125-200	292	86	3.4
12	250	442	86	5.0
	4-40	292	50.5	1.2
17.5	50-100	292	76	3.2
	125-200	442	86	5.0
	10-16	292	50.5	1.2
	25-40	292	76	3.2
	4-40	367	50.5	1.5
24	50-80	367	76	3.9
	100	367	86	4.6
	6.3-20	292	50.5	1.2
	25-31.5	292	76	3.2
	40-63	292	86	5.0
	6.3-20	367	50.5	1.5
	25-40	367	76	3.9
4-40	442	50.5	1.7	
10/24	50-80	442	76	4.5
	100	442	86	5.7

SIBA

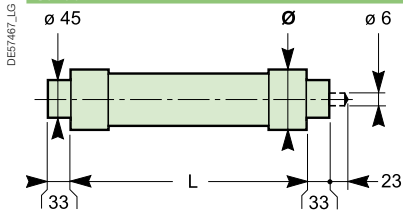

Ur (kV)	Ir (A)	L (mm)	Ø (mm)	Weight (kg)
3/7.2	6.3-50	292	53	1.6
	63-125	292	67	2
	160	292	85	3.8
	200-355	292	85	3.8
10/24	6.3-40	442	53	2.2
	50-80	442	67	2.9
	100-160	442	85	5.4
	200	442	87	5.4

Switch units

- **The switch can be closed** only if the earthing switch is open and the access panel is in position.
- **The earthing switch can be closed** only if the switch is open.
- **The access panel for connections can be opened** only if the earthing switch is closed.
- **The switch is locked** in the open position when the access panel is removed. The earthing switch may be operated for tests.

Circuit-breaker units

- **The disconnecter(s) can be closed** only if the circuit breaker is open and the front panel is locked (interlock type 50).
- **The earth switch(es) can be closed** only if the disconnecter(s) is/are open.
- **The access panel for connections can be opened** only if:
 - the circuit breaker is locked open,
 - the disconnecter(s) is/are open,
 - the earth switch(es) is/are closed.

Note: It is possible to lock the disconnecter(s) in the open position for no-load operations with the circuit breaker.

Functional interlocks

Our interlocks comply with IEC recommendation 62271-200.

In addition to the functional interlocks, each disconnecter and switch include:

- **Built-in padlocking** capacities (padlocks not supplied)
- **Four knock-outs** that may be used for keylocks (supplied on request) for mechanism locking functions.

Unit interlock

Units	Interlock											
	A1	C1	C4	A3	A4	A5	50	52	P1	P2	P3	P5
IM, IMB, IMC, IMM ⁽¹⁾				●	●				●			
PM, QM, QMB, QMC	●	●	●									
DMVL-A, DMVL-D	●	●	●				●					
CVM ⁽²⁾		●						●				
NSM				●					●			
GAM ⁽²⁾				●		●						●
SM										●	●	
DM2							●					
DMVL-M							●					

⁽¹⁾ Please consult us.

⁽²⁾ Coming in 2024, contact us for availability.

Key-type interlocks

Functional interlocks

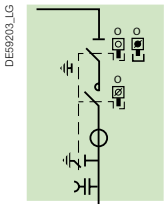
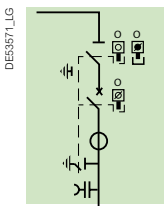

50 type

Avoids

- On-load switching of the disconnectors

Allows

- Off-load operation of the circuit breaker with the disconnectors open (double isolation)
- Off-load operation of the circuit breaker with the disconnector open (single isolation)

52 type

Avoids

- On-load switching of the disconnectors

Allows

- Off-load operation of the contactor with the disconnectors open (double isolation)
- Off-load operation of the contactor with the disconnector open (single isolation)

Legend for key-type interlocks:

MT2024EN

□ □ No key

□ □ Key released

□ □ Key captive

□ □ Panel or door

Outgoing units

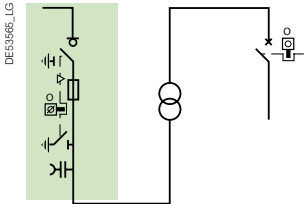

- A1 type**
- To avoid closing of the earthing switch on a transformer protection unit unless the LV circuit breaker is locked in the 'open' or 'disconnected' position

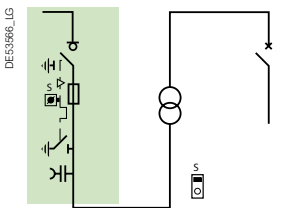

- C1 type**
- To avoid access to the transformer if the earthing switch for transformer protection has not first been closed

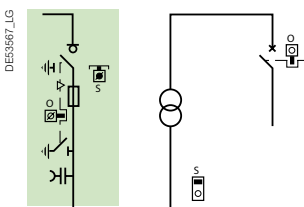

- C4 type**
- To avoid closing of the earthing switch on a transformer protection unit unless the LV circuit breaker is locked in the 'open' or 'disconnected' position
 - To prevent access to the transformer if the earthing switch for transformer protection has not first been closed

Ring units

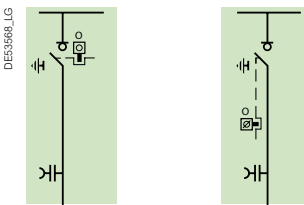

- A3 type**
- To avoid closing of the earthing switch on a load-side cubicle unless the line-side switch is locked 'open'

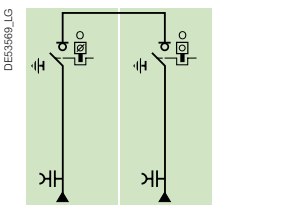

- A4 type**
- To avoid the simultaneous closing of two switches

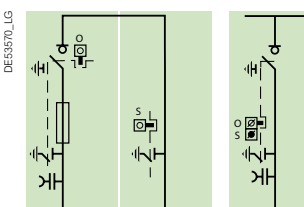

- A5 type**
- To avoid closing of the earthing switch on the casing unit unless the downstream and upstream switches are locked in the 'open' position

Legend for key-type interlocks:

MT20240EN

No key

Key released

Key captive

Panel or door

Ring units

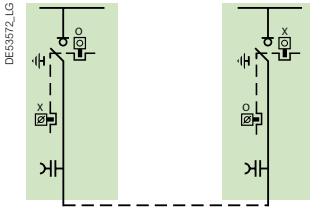

- P1 type**
- To avoid the closing of an earthing switch if the switch of the other unit has not been locked in the 'open' position

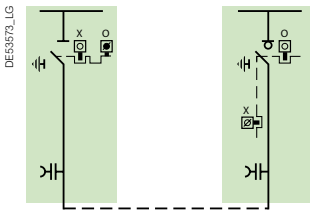

- P2 type**
- To avoid on-load operation of the disconnecter unless the switch is locked 'open'
 - To avoid the closing of the earthing switches unless the disconnecter and the switch are locked 'open'

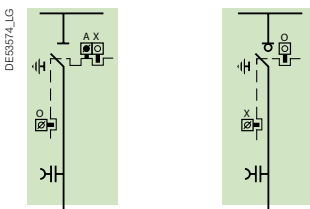

- P3 type**
- To avoid on-load operation of the disconnecter unless the switch is locked 'open'
 - To avoid the closing of the earthing switches with the unit energized, unless the disconnecter and the switch are locked 'open'
 - To allow off-load operation of the switch

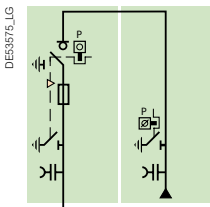

- P5 type**
- To avoid the closing of the earthing switch of the incoming unit unless the disconnecter or the switch is locked 'open'

Legend for key-type interlocks:

MT20240EN

No key

Key released

Key captive

Panel or door

Protection relays

PowerLogic™ P1 relay

Application

- Utility and industrial substation fitted with costoptimized MV switchboards
- Retrofit relays of old technology, particularly during installation of DCS systems
- Transformers, incomers, bus couplers, overhead lines and underground cables on MV systems
- Neutral system protection (insulated, solid and resistance earthed)
- LV substations.

Segments

- Commercial Industrial Buildings
 - Non-critical infrastructure
- Power & Grid
 - Non-demanding Distribution Utilities

Proven reliability

- Successor of MiCOM P111, Vamp V11 and Sepam10: more than 200,000 installations across the world
- Easy-to-use overcurrent, earth-fault and voltage-frequency protection relays for essential protection
- Suitable for MV and LV applications in non-demanding applications in Commercial & Industrial buildings
- Ideal for backup or retrofit applications due to standard applications and compact size
- Robust design, IP54 front panel

Main functions available

- Phase & E/F overcurrent; Thermal Overload protections
- Cold load pickup, Blocking logic discrimination
- Two setting groups (HMI/BI/RS485)
- SOTF, 2nd harmonic blocking,
- Recording: Faults (20), Events (200), disturbance (4s), Counters
- CB diagnosis: Circuit Breaker Failure, TCS, CB condition monitoring, operation time monitoring
- CB Control via RS485/HMI/Input and local/remote mode
- USB port and RS485 with Modbus/IEC 60870-103
- Above functions are available depending on Models and options: L, A, N, B, E
- Additional local or remote customisable controls with more inputs (up to 8 Digital inputs)

Ease of use

Save time and money with easy ordering, configuration, and operating processes. Configure through our intuitive HMI and setting tool, and mount in just 10 seconds with our spring clips.

Reliable

Enhanced safety and reliability with an insulated casing, non-volatile memory for settings and records, clock retention for 3 days, low energy consumption, and helps with circuit breaker wear monitoring.

Flexible

Optimized for compact switch gears and graded functionality to tailor to specific applications. PowerLogic P1 can be used in a variety of new and retrofit installations.



Models available:

- **PowerLogic P1F** - Feeder protection
- **PowerLogic P1V** - Voltage protection

Protection

PowerLogic™ P3 relay

Application

- Feeder and Line
- Motor
- Capacitor bank
- Generator and Transformer protection together with Arc flash detection

Segments

- Commercial Industrial Buildings
 - Non-critical infrastructure
- Power & Grid
 - Power Stations & Renewables
 - High Demanding Distribution Utilities
- Small Industries
 - Energy & Chemicals

P3 Standard
Universal applications

P3 Advanced
Advanced applications
with arc flash fault
detection



Models available:

- **PowerLogic P3U** - Universal (Feeder/Motor/Capacitor)
- **PowerLogic P3F** - Feeder protection
- **PowerLogic P3L** - Line protection
- **PowerLogic P3M** - Motor & Differential
- **PowerLogic P3G** - Generator & Differential
- **PowerLogic P3T** - Transformer Differential

Solid protection meets unparalleled efficiency

PowerLogic™ P3 products have been designed around user-friendliness, a feature which is proven in our customer feedback day after day.

The PowerLogic™ P3 feeder manager has been developed to cover basic protection needs for commercial and industrial buildings, distribution utilities and industrial applications. Thanks to its cost-effective and flexible design, the P3 provides an alternative for various protection applications.

The P3 relay range combines protection functions for feeder, line, motor, capacitor bank, generator and transformer protection applications

Ease of use

User-friendliness is a key benefit of PowerLogic P3, designed to save time at every step of the project's life-cycle.

A great deal of effort has gone into designing the operational aspects of the P3 products. Setting and download/upload are much convenient thanks to the unique eSetup Easergy Pro setting software which dramatically improves usability.

The informative human machine interface shows the information the user needs, with the support of customized legend texts.

Unparalleled efficiency

- Simple selection and ordering with EcoStruxure Power Build Medium Voltage.
- Faster delivery with on-the-shelf availability of standard configurations. Simplified configuration and virtual signal injection with the eSetup Easergy Pro setting tool.

Better Connectivity

- Simpler operation and maintenance with user-friendly tools.
- All communication protocols including Modbus, DNP 3, IEC 61850 and Profibus.
- Possibility to use two active communication protocols at the same time.
- Increased number of inputs and outputs for more controlling possibilities.

Enhanced safety

- Embedded arc protection.
- Select-execute circuit-breaker control
- Close-by wireless breaker operation
- Compliant to international standards (i.e. IEC 60255-1).

Protection

PowerLogic™ P5

Application

- HV backup protection
- Primary MV distribution
- In-built arc flash protection
- Automatic (fast) transfer switch
- Advanced IEC 61850 schemes
- Low power sensors (LPCT/LPVT)
- Harsh environment

Segments

- Cloud & Service Providers, Hospitals, Airports
– Critical Infrastructure
- Power & Grid
– Power Stations & Renewables
– High Demanding Distribution Utilities
- Small Industries
– Energy & Chemicals
- Oil & Gas, MMM, Large Industries
– Energy & Chemicals

All-in-one best-in-class features

The PowerLogic™ P5 presents a major step forward for protection relays, bringing a number of best-in-class features together in one device.

Built-in arc flash protection

Arc-flashes will always exist when switching or during unexpected conditions. If the protection function detects an arc-flash, it isolates the connected circuit breaker within milliseconds, preventing a growing arc-flash energy and thus an unexpected risk of outage.

Advanced cybersecurity

PowerLogic P5 is one of the first protection relays to be third-party certified according to IEC 62443 4-2 standard at Security Level 1. This means reduced exposure to cyber threats and improved operational security.

Intuitive withdrawable design

With a handle built in as part of the design, the P5 can be quickly disconnected or exchanged to speed up maintenance. Wiring, data, communication, and settings (including backup) can be stored with the panel and will be there when the relay is reconnected.

Improved recovery time

When maintenance or testing is required, PowerLogic™ P5 helps dramatically decrease your outage recovery time. The backup memory can automatically restore settings, you can continue your operations in as little as 10 minutes*.

* Result of mean time to repair (MTTR) calculation conducted by Schneider Electric.

Greater connectivity

The protection relay features seven communication protocols. This includes compliance with IEC 61850 ed.1 and ed.2, Modbus (serial/TCP), IEC 60870-5-103, IEC 60870-5-101, Ethernet/IP, and DNP3 (serial/TCP). Additionally, thanks to the P5's modular design, communication ports can be added at any time to enable you to upgrade your device in line with future network upgrades.



Models available:

- **PowerLogic P5U** - Universal (Feeder/Transformer/Motor)
- **PowerLogic P5F** - Feeder & Generator protection
- **PowerLogic P5T** - Transformer Differential
- **PowerLogic P5L** - Directional & Line protection
- **PowerLogic P5V** - Voltage/Frequency protection
- **PowerLogic P5M** - Motor protection

Custom applications

Easergy Sepam series 80



Demanding applications

Easergy Sepam series 60



Models available Easergy Sepam:

- **S60, S62, S80, S82, S84** - Substation protection
- **M61, M81, M87** - Motor protection
- **T60, T62, T81, T82, T87** - Transformer protection
- **G60, G62, G88** - Generator protection
- **C60, C86** - Capacitor protection
- **B80, B83** - Busbar protection

Segments

- Nuclear
- Power & Grid
 - Demanding Distribution Utilities
 - High Demanding Distribution Utilities
- Oil & Gas, MMM, Large Industries
 - Energy & Chemicals

Easergy Sepam: protection digital relays

Go for simplicity

With multi-functional Sepam protection relays, you can measure, manage, analyze and produce diagnostics for all applications in an installation. Range modularity makes it easy to select the relay corresponding exactly to your needs.

The range is structured for typical applications (substations, transformers, generators, capacitors, busbars and motors) and provides the necessary functions for each application (protection, metering, control and monitoring, etc.).

Starting with a Sepam base unit, complete solutions can be built up by adding input/ output modules, sensors and communication modules.

Communicate the open way

In addition to the DNP3, IEC 60870-5-103 and Modbus standards, Easergy Sepam complies with IEC 61850 (GOOSE messages, TCP/IP redundancy) and uses the communication protocol that is today's market standard to interface with all brands of electrical distribution devices.

Protection

Protection and sensor selection table

General common selection of protection units

Protection type	Code	Protection units			
		PowerLogic P1	PowerLogic P3	PowerLogic P5	Easergy Sepam series 60 series 80
Three-phase overcurrent	50 - 51	•	•	•	• •
Zero-sequence overcurrent	50N - 51N	•	•	•	• •
Directional zero-sequence current	67N	•		•	• •
Undervoltage	27	• (*)		•	• •
Overvoltage	59	• (*)		•	• •
Thermal image	49	•	•	•	• •
Zero-sequence overvoltage	59N	• (*)		•	• •
Negative sequence overcurrent	46	•	•	•	• •
Long start-up and rotor blocking	51LR		•	•	• •
Maximum number of start-ups	66		•	•	• •
Single-phase undercurrent	37		•	•	• •
Communication		•	•	•	• •

(*) Available on P1V Voltage and Frequency prot. Relay.

Custom applications



Sepam series 60 and 80

TLP130, sensors for PowerLogic Sepam series 60, 80 protection units

LPCT sensors are voltage-output current sensors

(Low Power Current Transformer) compliant with the standard IEC 618869-11. These sensors are designed to measure rated current between 5 A and 630 A, with a ratio of 100 A / 22.5 mV.

Sepam series 60 and 80 protection units are at the heart of the LPCT protection chain

Sepam series 60 and 80 perform the following functions:

- Acquisition of phase currents measured by the LPCT sensors
- Utilization of measurements by the protection functions
- Tripping of the breaking device in case of fault detection.

Advantages

Consistent protection chain with the same sensor measures phase currents from 5 A to 630 A

- Simple to install and implement:
 - Installation of LPCT sensors
- TLP130 and TLP190 are installed around MV cable
- CLP2 is installed on the MV circuit
 - LPCT connected directly to Sepam series 60 and 80
 - Accessories available to test the LPCT protection chain by secondary current injection.
- LPCTs range of use
LPCT measuring and protection function helping guarantee the accuracy up to the short-time current.

Following the range of use of LPCT:

- From 5 A up to 1250 A respecting the error limits imposed by the accuracy class 0.5
- From 1250 A up to 50 kA respecting the error limits imposed by the accuracy class 5P.

Optimized integration of functions:

- Measurement of phase rated currents as of 25 A that is set by micro-switch
- Monitoring of LPCT sensor by Sepam series 60 and 80 (detection of phase loss).

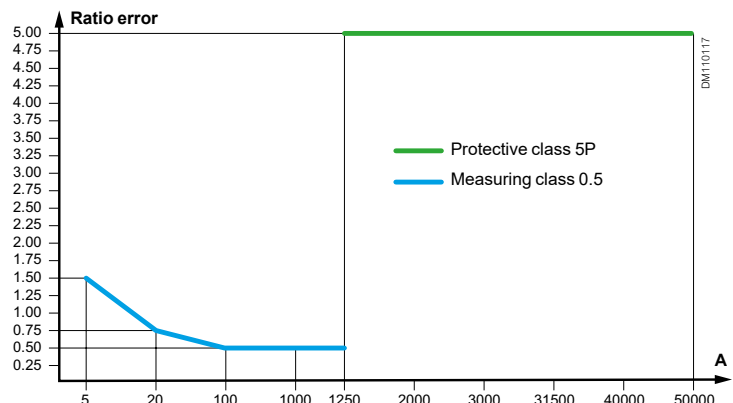

New LPVT for PowerLogic P3 and PowerLogic T300



PowerLogic T300



PowerLogic P3

Compact high accuracy Low Power Voltage Transformers (LPVT).

The LPVT is based on the capacitive divider principle and the voltage output is proportional to the MV network voltage:

The linearity and high accuracy are delivered in the whole operating range and allow the combination of metering and protection classes in one LPVT.

These innovative LPVTs are ideal for the new generation of electronic protection devices such as PowerLogic P3 relays and PowerLogic T300 RTU helping to ensure:

- Accuracy class 0.5P for metering and protective applications
- Low power consumption and reduced size
- Excellent accuracy for harmonic measurement allowing Quality Metering
- Reliability with LPVT ferroresonance free
- Complies with international standard IEC 61869-11.

PowerLogic P3 protection unit is the heart of the LPVT protection chain.

PowerLogic P3 relays perform the following functions:

- Acquisition of phase voltages measured by the LPVT
- Utilization of measurements by the protection functions
- Tripping of the breaking device in case of fault detection.

Advantages

Consistent protection chain with the same LPVT for MV voltage network from 5 kV to 23 kV:

- LPVT integrated in already existing insulator
LPVT connected directly to PowerLogic P3 or PowerLogic T300.

Fault passage indicators

Flair 21D, 22D and 23DM

Flair 21D, 22D, 23DM is a family of DIN format fault passage indicators. They are small in size, self-powered and adapt automatically to the network.

These devices use cutting-edge technology to detect earth faults on underground MV networks with isolated, resistor-earthed or directly earthed neutral and overcurrents on **all** networks.

- Self-powered, the fault current passage detection and indication system operates continuously.
- Adjustment-free, they are immediately operational (numerous manual adjustments are however possible).
- Compact, their DIN format easily fits in MV cubicles.
- Smart, they offer an ammeter/digital maximeter function.
- Comprehensive, the Flair 23DM version incorporates a highly sophisticated voltage presence/absence relay function with RJ45 Modbus communication.

Applications and main features

The Flair range increases your power availability by providing indicators suitable for fault locating and MV network load management.

- Indication of phase-phase and phase-earth faults
- Display of settings
- Indication of the faulty phase
- Display of the load current including peak demand and frequency
- Fault passage indication and voltage detection combination (Flair 23DM)
- RJ45 communication (Flair 23DM only).

These fault passage indicators are **robust** and easy to use.

- Automatic setting on the site
- Fault indication with LED or outdoor lamp
- 15-year battery life for Flair 22D
- More accurate fault detection if Flair 22D or 23DM is connected to voltage indication system (VDIS) voltage output
- Can be factory-mounted in SM AirSeT cubicles or added on the site
- Easy on-site addition without removing MV cables using split-type current sensor.

Standard applications

Flair 21D

PM108331



Maintenance-free, adjustment-free fault detector.

Flair 22D

PM108332



Fault detector for networks with very low load current (< 2 A) with possibility of manual adjustments.

Flair 23DM

PM108082



Adapted to Feeder Automation. Forwarding of current measurement, fault passage indication and voltage outage information to the SCADA via a serial communication port. Combination fault passage indicator and voltage detector, ideal for use with an Automatic Transfer System.

The Flair 21D, 22D, 23DM range uses an integrated detection system composed of indicators and dedicated CTs. Integrated sensors are normally placed around the bushings. Split CTs can be placed around cables for retrofit purposes.

Display principle

- The load current is displayed continuously.
- When a fault is detected, the faulty phase is indicated.
- Use the buttons on the front panel to scroll through settings and measurements.

Fault detection functions

Overcurrent detection

- Automatic mode for adjustment-free calibration of detection thresholds.
- Manual mode for special override settings:
 - Flair 21D: 4 detection thresholds from 200 A to 800 A, in 200 A increments, selectable via microswitches
 - Flair 22D and Flair 23DM: 8 detection thresholds from 100 A to 800 A, in 50 A increments, configurable via the front panel keypad.
- Fault acknowledge time:
 - Flair 21D: 40 ms
 - Flair 22D and Flair 23DM (configurable via the front panel keypad):
 - Type A from 40 to 100 ms in 20 ms increments
 - Type B from 100 to 300 ms in 50 ms increments.

Earth fault detection

The detector checks the 3 phases for current variations (di/dt).

A time delay of 70 s is applied for fault confirmation by the upstream protective device.

- Automatic mode for adjustment-free calibration of detection thresholds.
- Manual mode for special override settings:
 - Flair 21D: 6 detection thresholds from 40 to 160 A, via microswitches
 - Flair 22D and Flair 23DM (configurable via the front panel keypad):
 - Type A from 20 to 200 A, in 10 A increments
 - Type B from 5 to 30 A in 5 A increments and 30 to 200 A in 10 A.
- Inrush function: **helps in preventing** unnecessary detection in the event of load switch-on.
Incorporates a 3 s time delay for fault filtering at network power up.
The Inrush function can be disabled via configuration on Flair 22D and 23DM.

Fault indication function

Signaling

As soon as a fault is confirmed, the indication device is activated.

- Fault indication via a red LED on the front panel
- Indication of the faulty phase (earth fault) on LCD display
- Optional remoting of indication to external flashing lamp
- Activation of a contact for retransmission to the SCADA system.

Indication reset

- Automatic reset upon load current recovery (configurable time delay on Flair 22D and Flair 23DM)
- Manual reset via front panel button
- Reset via external Reset input
- Reset by time delay: fixed (4 hr) for Flair 21D and adjustable using front panel keypad (1 hr to 24 hr) for Flair 22D and Flair 23DM.

Fault passage indicators

Flair 21D, 22D and 23DM

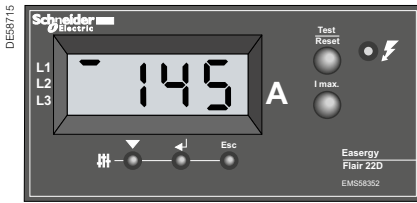

Connection diagrams

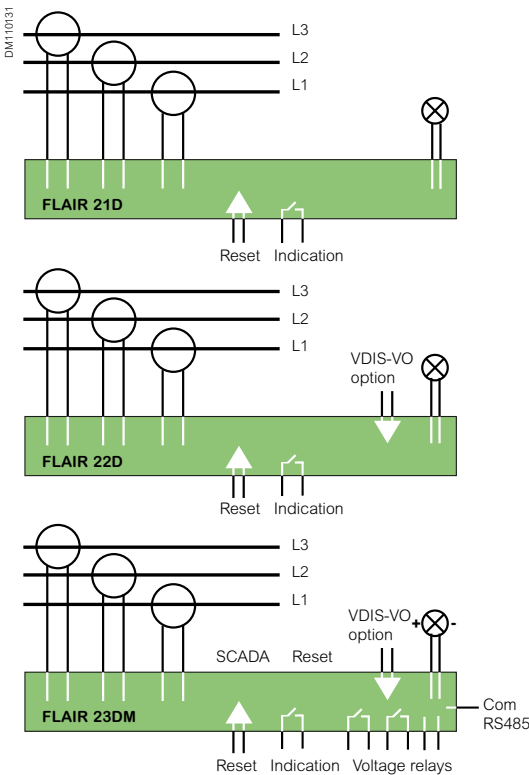

Selection table

		Flair		
		21D	22D	23DM
Power supply	Self-powered	●	●	●
	Dual-powered		● (1)	●
Detection	Overcurrent		●	●
	Earth-fault		●	●
	Ammeter		●	●
	Maximeter		●	●
	SCADA interface (relay)		●	●
Display (4 digit LCD)	External lamp		●	●
	External reset		●	●
	Extended setting (keypad)		●	●
	2-voltage output relays			●
Communication	Serial communication port			●

(1) By lithium battery.

Characteristics per product

Model	Description
Fault passage indicator with single power supply (self-powered)	
Flair 21D	Detector with autonomous power supply External indicator lamp output powered by battery (BVP)
Fault passage indicator with dual power supply	
Flair 22D	Detector with autonomous power supply and lithium battery External indicator lamp output powered by the Flair (BVE) Zero sequence CT option (type B setup) Interface with VDIS-VO possible to confirm the fault by voltage absence
Fault passage indicator with dual power supply and voltage presence/absence	
Flair 23DM	Detector with 24-48 Vdc external and autonomous power supply External indicator lamp output powered by the Flair (BVE) Zero sequence CT option (type B or C setup) Voltage presence and absence detector (same as for VD23) Interface with VDIS -VO needed for the voltage presence

- At the leading edge of technology, Amp 21D is suitable for Medium Voltage network load management.
- Self-powered, it permanently displays currents.
- Compact and in DIN format, it fits naturally into MV cubicles.
- Cost efficient, it uses the CT optimized for Fault Passage Indicator.
- Performant, it displays phase current and current maximum



The **SM AirSeT** can integrate the **Amp 21D ammeter** on all incoming cubicles and on switch-fuse cubicles

Display principle

- Load currents are permanently displayed, continuous scrolling of L1, then L2, then L3.
- Maximeter
 - access to maximeter display by pressing a dedicated push button
 - continuous scrolling of M1, then M2, then M3
 - reset of all maximeter displays by pressing a combination of two push buttons.

Functions

- Display of 3 phase current: I1, I2, I3. Range: 3 A to 630 A.
- Display of 3 phase current maximeter: I1, I2, I3. Range: 3 A to 630 A.

Connections, assembly

Small size enclosure

- DIN format: 93 x 45 mm
- Anti-extraction-proof mounting
- Terminal connections

Current sensors

- Split core CT for mounting on MV cables

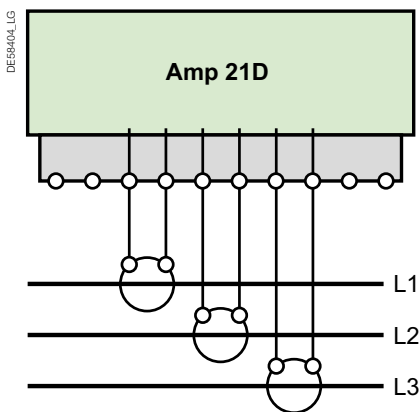

Technical data

Application

Frequency	50 Hz and 60 Hz
Load current	Minimum current ≥ 3 A

Measurement

Range	Phase current	3 to 630 A (resolution 1 A)
	Accuracy ($I < 630$ A)	$\pm (2\% + 2 \text{ digit})$
Reset of maximeter	Manual from device	Yes

Power supply

Self power	From the current sensors	$I \text{ load} \geq 3$ A
Battery		No
Auxiliary supply		No

Display

Display	4 digits LCD
Current per phase	Yes (resolution 1 A)
Maximeter per phase	Yes

Sensor

Phase CTs	3 split core CT
-----------	-----------------

Miscellaneous

Test	Yes
------	-----

Protection

PowerLogic™ A1 & A3 relay

Application

- Feeder
- Motor and voltage and frequency
- Distance
- Line differential
- Transformer

The PowerLogic™ Arc range can be deployed in a single MV cubicle where three sensors can secure the arc protection up to medium size application with numbers of MV switchgears or LV switchboards.

The connection flexibility and the easy logic built for common protection schematics, makes this range accessible and easy to use for more applications.

Selecting the right device becomes simple and helps to avoid any error.

The PowerLogic™ Arc range for small to medium size applications is composed by:

- PowerLogic™ A1: stand-alone device for cubicle protection.
- PowerLogic™ A3: can be used as stand-alone device or associated to other A3 devices and build a system solution. PowerLogic™ A3 devices could be connected through a high-speed bus to perform high performance protection at system construction.

PowerLogic™ A1 and A3



PowerLogic™ A1

- Models available: **A125 / V125**
- Dedicated unit for each bay - versatile and independent device for each bay
- Designed for partners with optimized, cost effective solutions of panel builders and OEMs.

Control

Motorization control

The Control Terminal Block (CTB) is a device designed to control all the components involved in the remote control of core units.

It integrates all the necessary functions for reliable remote control:

- Electrical interlocking
- Remote control supervision
- Front panel interface for local operation

Control Terminal Block (CTB)

The CTB is a compact device with digital inputs and outputs to drive and control all the components associated with the electrical operation of the core unit:

MCH, MX, XF, MN auxiliary contacts.
It can be associated with a local HMI.

Switchgear control functions

- Coil and motor operation
- Information on switch status: main switch, earthing switch
- Built-in electrical interlocks and anti-pumping
- Lockout of electrical operation after tripping

CTB is available with 3 different level of control voltage. For all types of CTB, Motor voltage can be from 24 Vdc to 240 Vac.



CTB CD1/CD2

CTB	12DC	24DC	48DC
12 Vdc	•		
24 Vdc		•	
48/60 Vdc			•

Unitary CTB wiring

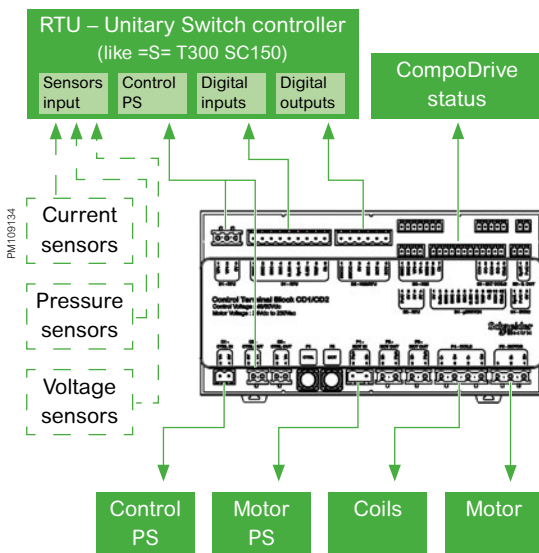

Motor voltage

- Power supply
- DC: 24 V, 48 V, 60 V, 110 V, 125 V
 - AC: 110 V, 125 V, 240 V

Monitoring & control

PowerLogic Thermal Sensor TH110

PM111027



Continuous Thermal Monitoring

The power connections in the Medium Voltage products are amongst the most critical points of the substations, especially for those made on site such as MV cable connections.

Loose and faulty connections cause an increase of resistance in localized points that will lead to thermal runaway leading to complete failure of the connections. Preventive maintenance can be complicated in severe operating conditions, due to limited accessibility and visibility of the contacts.

Continuous thermal monitoring is the most appropriate and timely way to detect a compromised connection.

PM109830



TH110

PowerLogic Thermal Sensor TH110

Is part of the **new generation of wireless smart sensors** helps to ensure the continuous thermal monitoring of all the critical connections made in field allowing to help:

- Prevent unscheduled downtimes
- Increase operator and equipment safety
- Optimize predictive maintenance.

Thanks to its very **compact footprint** and its **wireless communication**, PowerLogic Thermal Sensor TH110 allows an easy and widespread installation in all possible critical points without impacting the performance of the MV Switchgears. By using **Zigbee Green Power** communication protocol, PowerLogic Thermal Sensor TH110 helps to ensure a reliable and robust communication that can be used to create interoperable solutions evolving in the Industrial **Internet of Things** (IIoT) age.

PowerLogic Thermal Sensor TH110 is **self powered** by the network current and help ensure **high performance** providing accurate thermal monitoring, being in **direct contact** with the measured point.

PowerLogic Environmental Sensor CL110

Schneider Electric ambient monitoring system will continuously:

- Help the maintenance manager to avoid deterioration of the MV switchgear due to moisture and pollution.
- By automatically calculating the condensation cycle, and combining it with the declared mission profile conditions, the system will recommend maintenance and cleaning frequency adjustment in order to maintain the switchgear in its nominal status.

Monitoring & control

Wireless Environmental Monitoring PowerLogic CL110

Key benefits

- Long battery life expectation
- Wireless communications
- High performances
- In contact measuring point for temp.
- Easy installation with magnets
- Compact footprint
- Remote monitoring and alarming



PowerLogic CL110

Characteristics

Temperature Accuracy	+/- 1 °C in a range from -25 °C to 90 °C
Relative Humidity Accuracy	2% in a range from 10% to 98%
Wireless Communication	ZigBee Green Power 2.4 GHz
Protection degree	IP54
Dimension - weight	40 x 40 x 21 mm – 34 g
Power supply	3 V battery

Continuous Environmental Monitoring

Harsh environment due to pollution, condensation and strong temperature drifts is one of the most critical failure cause due to accelerated aging.

In **MV Switchgears** an harsh environment generate dirt that, on the surface of unshielded insulators, can lead to surface partial discharges up to a complete flashover.

In **LV compartments** an harsh environment can generate rust on metallic parts and electronic contacts.

The continuous environmental monitoring is the most appropriate way to early detect installation issues, optimizing maintenance with predictive information.

PowerLogic CL110 Environmental Sensor

PowerLogic CL110 is part of the **new generation of wireless smart sensors** helps to ensure continuous environmental condition monitoring enabling, over a de-energized surface, the measurement of:

- Temperature of the surface in contact
- Relative humidity

By using proper algorithms, the above data can be computed to calculate the dew point and condensation occurrence.

Thanks to its **compact footprint** and its **wireless communication** PowerLogic CL110 allows an easy and widespread installation also providing IP54 degree of protection in indoor applications.

PowerLogic CL110 is **battery powered with life expectation >15 years** and it allows a simple fixing on magnetic metal surfaces thanks to its **high-strength magnets**.

By using **Zigbee Green Power** communication protocol, PowerLogic CL110 helps to ensure a reliable and robust communication that can be used to create interoperable solutions evolving in the **Industrial Internet of Things (IIoT)** age.

PowerLogic CL110 provides accurate temperature monitoring of the metal surface being in **direct contact** with it.

Substation Monitoring Device

PowerLogic CL110 is **connected** to the Substation Monitoring Device (SMD) that harvests the data for local signaling, data analyses and nearby display.

Specific **monitoring algorithms** allow to detect drifts from the threshold based on the specific installation characteristics.

The remote **monitoring and alarming** helps to ensure full peace of mind thanks to remote connection for SCADA or Services, access to Cloud-based Apps and digital services and alarming through SMS or EcoStruXure Power Device App.

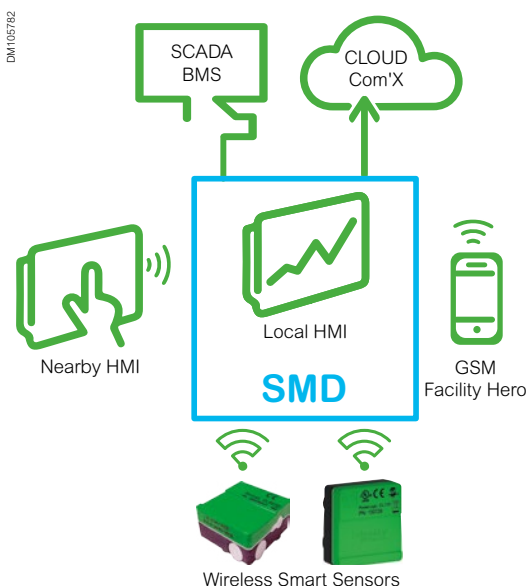

DM105762

Monitoring & control

PowerLogic T300 S

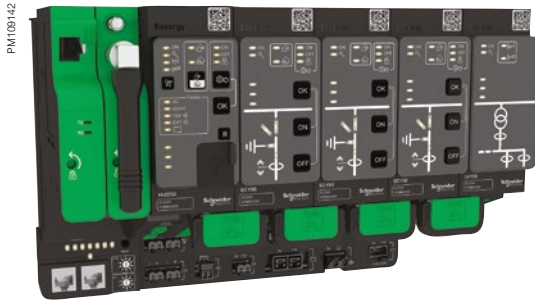

PowerLogic T300 unit

PowerLogic T300 S for NSM cubicle

PowerLogic T300 S is a simplified MV substation control unit for secondary distribution networks enabling remote control of one or two MV substation switches. T300 S, a version of the T300 unit, is integrated in to the SM AirSeT cubicle LV control cabinet.

It is limited to control two switches. It is intended for remote control applications for source transfer switching and back-up generator set switching in a NSM cubicle.

PowerLogic T300 S a multifunctional 'plug and play' interface which integrates all functions required for remote monitoring and control of MV substations:

- Acquisition of various data types: switch position, fault detectors, current values, etc.
- Transmission of opening and closing orders to the switches.
- Exchange with the control center.

Particularly used during network incidents, PowerLogic T300 S has proven its reliability and ability to operate the switchgear at all times. It is easy to implement and operate.

Functional unit dedicated to Medium Voltage applications

PowerLogic T300 S is installed in the low voltage control cabinet of NSM cubicles for remote control of one or two switches.

PowerLogic notably enables source transfer switching between two switches.

It has a simple panel for local operation to manage electrical controls (local/remote switch) and to display switchgear status information.

It integrates a fault current detector with detection thresholds configurable channel by channel (threshold and fault duration).

'Plug and play' and robust

Integrated in the low voltage control cabinet of an MV-equipped cubicle, it is ready to connect to the data transmission system.

PowerLogic T300 S has been subject to severe tests on its resistance to MV electrical constraints. A back-up power supply supports to provide several hours continuity

of service for the electronic devices, motorization and MV switchgear.

Current transformers are of split core type for easier installation.

Compatible with all SCADA remote control systems

PowerLogic T300 S supplies the following standard protocols:

- IEC 60870-5-104 Client and Server
- IEC 60870-5-101 Client
- DNP3 Client and Server
- Modbus Server and Client
- IEC 61850 Server and Client.

Data transmission system standards are: Ethernet, RS232-RS485, GPRS, 2G, 3G, 4G.

Other systems are available on request, the radio frequency emitter/receiver is not supplied.

See the detail of [PowerLogic T300 catalogue](#) 



Split core CTs

Monitoring & control

PowerLogic T300 I

Ready to plug

- PowerLogic T300 I is delivered with a kit that makes it easy to connect the motor mechanisms and collect measurements.
- The connectors are polarized to help avoid any errors during installation or maintenance interventions.
- Current measurement acquisition sensors are of the split type, to facilitate their installation.
- Works with 24 Vdc and 48 Vdc motor units.

PowerLogic T300 I: an interface designed for control and monitoring of MV networks

PowerLogic T300 I is a 'plug and play' or multifunction interface which integrates all the functional units necessary for remote supervision and control of the SM AirSeT:

- Acquisition of the different types of information: switch position, fault detectors, current values
- Transmission of switch open/close orders
- Exchanges with the control center
- Cybersecurity features.

During network outages PowerLogic T300 I helps ensure switchgear operation at any moment. **It is simple to set up and to operate.**

Functional unit designed for the Medium Voltage network

- PowerLogic T300 I is designed to be connected directly to the MV switchgear, without requiring a special converter.
- It has a simple front plate for local operation, which allows management of electrical rating mechanisms (local/remote switch) and display of information concerning switchgear status.
- It has an integrated MV network fault current detection system (overcurrent and zero sequence) with detection set points that can be configured channel by channel (current value and fault current duration).

Medium Voltage switchgear enhanced operating guarantee

PowerLogic T300 I has undergone severe MV electrical stress withstand tests. It is a backed up power supply which helps guarantee continuity of service for several hours in the event of loss of the auxiliary source, and supplies power to the PowerLogic T300 I and the MV switchgear motor mechanisms.

Compatible with all SCADA remote control systems

PowerLogic T300 I supplies the following standard protocols:

- IEC 60870-5-104 Client and Server
- IEC 60870-5-101 Client
- DNP3 Client and Server
- Modbus Server and Client
- IEC 61850 Master and Client.

Data transmission system standards are: Ethernet, RS232-RS485, GPRS, 2G, 3G, 4G.

Other systems are available on request, the radio frequency emitter/receiver is not supplied.

PM108088



PM109142

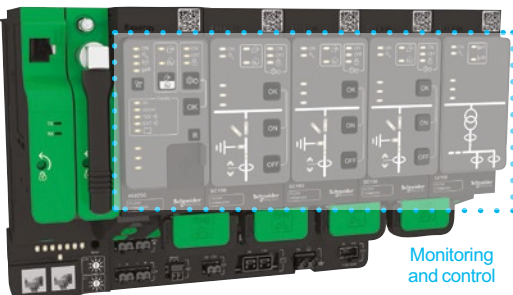

Monitoring and control

Voltage detection relay

VD23 provides accurate information of presence or absence of voltage. Associated with VDIS-Voltage Output, VD23 is typically used in critical power and safety applications.

Various combinations of voltage detection are possible:

- 3 Ph-N and residual voltage: $V1 + V2 + V3 + V0$.
- 3 Ph-N or Ph-Ph voltage: $V1 + V2 + V3$ or $U12 + U13 + U23$.
- 1 Ph-N or Ph-Ph or residual voltage: $V1, V2, V3, U12, U13, U23, V0$.

VD23 can display the MV network voltage (in % of service voltage), activate the relay output R1 to monitor a loss of voltage on 1 phase at least and activate the relay output R2 to monitor a presence of voltage on 1 phase at least.

- Auxiliary power supply: from 24 to 48 Vdc.
- Assembly: compact DIN format, mounted in the same place as fault passage indicator (format DIN, integrated in switchgear), terminal connection fitted with VDIS-Voltage Output.

PE41862



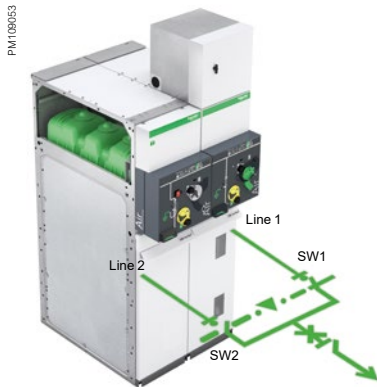

ACO solution

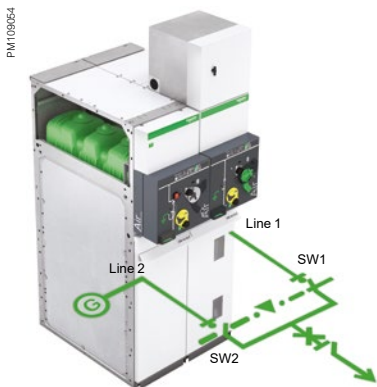

GEN solution

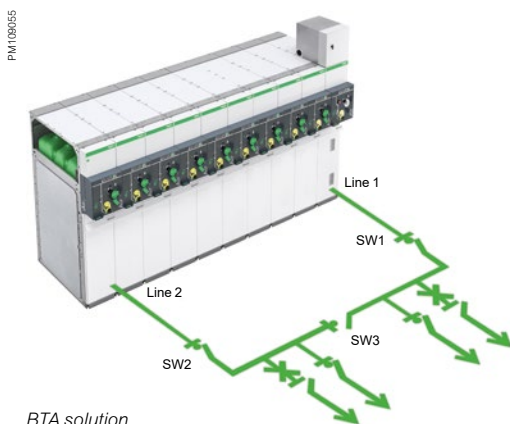

BTA solution

EcoStruxure ATS solution architectures

ACO - Automatic transfer between 2 MV lines

Standard ACO (Auto Change Over) transfers the power source to the alternate supply if the preferred source is lost. It may be set to automatically return to the preferred source when restored.

GEN - Automatic transfer with a standby generator

GEN (automatic transfer to a GENset) starts the standby generator upon loss of the distribution utility MV power source outage. An option is to combine two separate MV sources coming from the distribution utility, and one standby generator.

BTA - Automatic transfer and coupling

BTA (Bus-Tie Automatic transfer) isolates the faulty MV power source and switches both loads to the healthy MV power source, by opening SW1 (or SW2) and closing SW3 (busbar coupling).

PowerLogic T300 includes two types of automation systems:

Preset automation systems

Some automation system functions are factory defined and integrated (optional) in the basic functions of PowerLogic T300.

These functions require no on-site programming. They correspond to known operations widely used for the MV substation switch management application:

- Automatic Transfer of Source (ATS).
- Sectionalizer (SEC).

An IEC 61131-3 programmable logic controller

An RTU Control programming workshop is used to create automation functions in addition to the preset ones of the PowerLogic T300, in order to create and tailor specific applications.

Note: PowerLogic T300 can be controlled either with the preset automation systems or with the built-in IEC61131-3 programmable logic controller, but exclusively.

The automation systems can be switched on and off from the local operator panel and disabled using the Web server.

Switches can be controlled manually when the automation system is switched off and Control mode is in Local mode.

For more information about the IEC 61131-3 programmable logic controller of T300, please consult the PowerLogic T300 Catalog. [📄](#)

Functions	PowerLogic T300 (ACO)	PowerLogic T300 (GEN)	PowerLogic T300 (BTA)
Native in PowerLogic T300 I	●		
Using existing T300 application note (consult us)		●	
Using existing IEC 61131-3 program (consult us)			●
Back to normal source configurable/settable (self return mode) III	●	●	●
Block transfer to one source configurable (no return mode) II	●		●
Transfer with close transition configurable (parallel coupling mode) II		●	●
Time slot to back to normal source II		●	●
Load shedding capability II		●	●
GENset test function (temporally start genset) I		●	
Transfer lock on downstream current fault detection III	●	●	●
Push buttons (ATS ON/OFF; Remote/Local, source forcing,...) III	●	●	●
Interlock on digital inputs 2 2 3	2	2	3

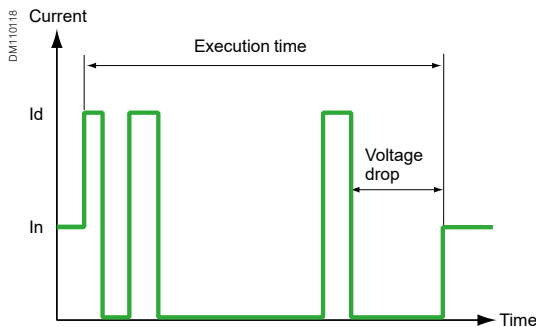

Sectionalizer (SEC)

Sectionalizer automation is controlled by each SC150 module. Each switch managed by a SC150 module can be activated with SEC automation.

The sectionalizer automation system opens the switch after a predefined number of faults (1 to 4) during the voltage dip in the reclosing cycle of the top circuit breaker.

- The automation system counts the number of times a fault current followed by a voltage loss is detected. It sends an open order if:
 - the switch is closed
 - the fault has disappeared
 - the MV supply is absent.
- The automation system is reset at the end of the execution time delay.

Configurable parameters:

- Number of faults: from 1 to 4
- Execution time: from 0 to 5 mins configurable
- Operation transfer time from 300 ms to 4 mn configurable
- Automation system valid/invalid

ATS automatic transfer system (source changeover)

EcoStruxure ATS solution benefits

- Ease the monitoring, control and maintenance of your Medium Voltage network.
- In case of 1 MV line loss:
 - restore total supply in 300 ms with SM AirSeT NSM
 - restore total supply as soon as the generator has started (within a pre-determined time and without any human operation).

Description

ATS automation is controlled by the HU250 module and so activated globally for all the SC150 modules of PowerLogic T300. ATS can control only two switches maximum, even if several SC150 modules are present in the unit.

An ATS system allows a critical load (such as a network section, a hospital or manufacturing plant) to have increased supply availability by switching between a primary and a backup supply.

- Automatically transfers between alternate supplies if one is lost.
- Can be set to automatically return to the preferred supply when it is restored.

ATS function can be used with standby generators but this requires additional custom logic to be defined using Formulas or ISaGRAF®.

ATS requires a voltage presence/absence indication per switch. This can be calculated either from the voltage measurement (sensors) of SC150 or from an external information connected to DI6 input on the SC150 (i.e. VD23 relay).

The Source transfer can be blocked by various inputs depending on the configuration. In addition, automation functions are enabled or disabled globally on PowerLogic T300 either remotely from the SCADA system or locally.

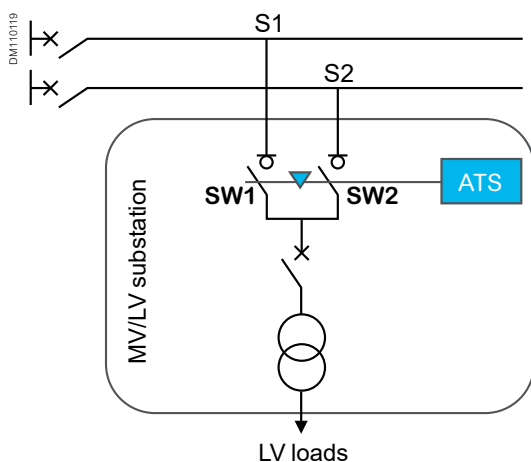

Monitoring & control

PowerLogic T300 Automation systems

What if there are no MV ATS solutions?

In critical areas (operation rooms, intensive care units, IT critical systems) where no outage is tolerated, the continuity of service is supported by UPS. However, the duration of the backup power is limited by the size of the UPS batteries.

The UPS system is generally backed up a LV standby generator, before UPS batteries are empty. However, (1) starting the LV generator takes time and (2) while its autonomy is quite extended, it is a costly solution that requires maintenance and, (3) its power delivery capacity is limited.

How does it impact your site?

The orange zone is reenergized only several minutes after the outage and the yellow zone is not reenergized until the MV power supply source has returned.

DM110120

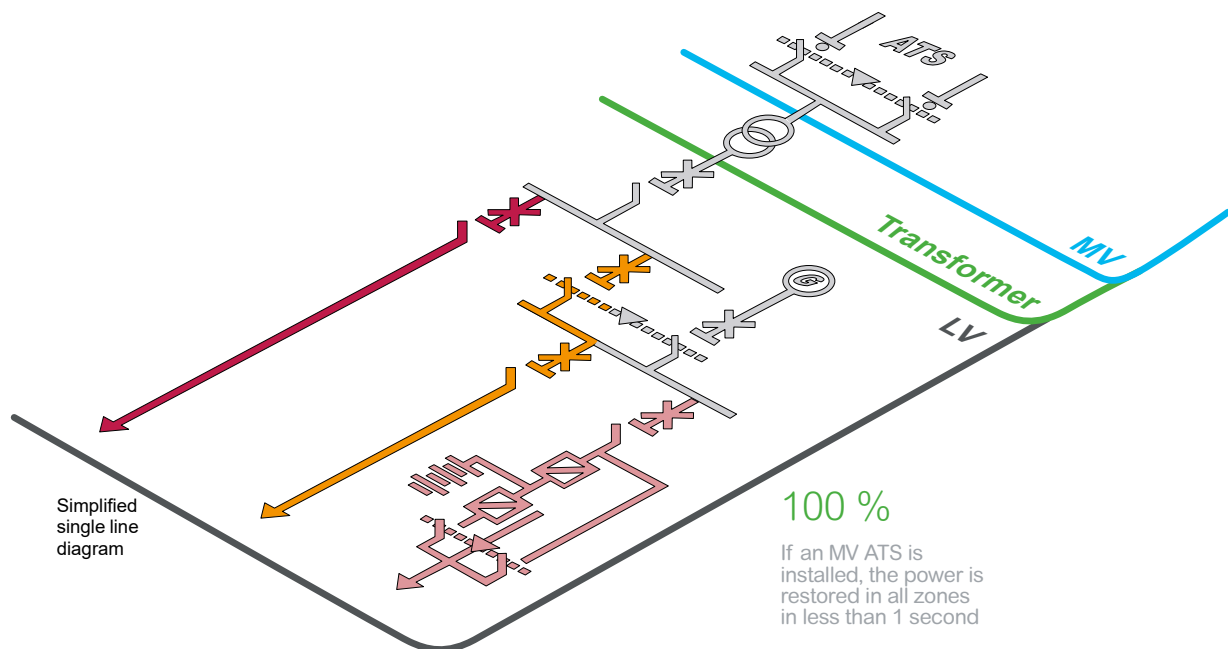

Modularity of the PowerLogic T300

Auto Transfer Switch application is controlled by the HU250 module and so activated globally for all the SC150 modules of PowerLogic T300. SEC application is controlled and managed by each SC150 module of PowerLogic T300.

PowerLogic HU250 Head Unit communication gateway	PowerLogic SC150 Switch Controller	PowerLogic PS50 Power Supply
 <p>ATS logic controller embedded. Log of transfer sequence and alarms. Remote monitoring (Webmaster, SCADA). Cybersecurity access control.</p>	 <p>Control and monitoring of all switchgears. Advanced FPI* which can lock the transfer. MV voltage and current monitoring. Power measurement and power quality. SEC automation function embedded.</p>	 <p>ATS and SEC available even during a black out. Only one monitored battery needed to facilitate the maintenance.</p>

DM110121
Network ATS: Self-return mode
(with paralleling upon automatic return)

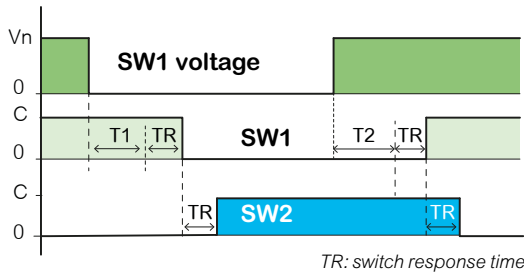

Network ATS: Auto-return mode
(without paralleling upon automatic return)

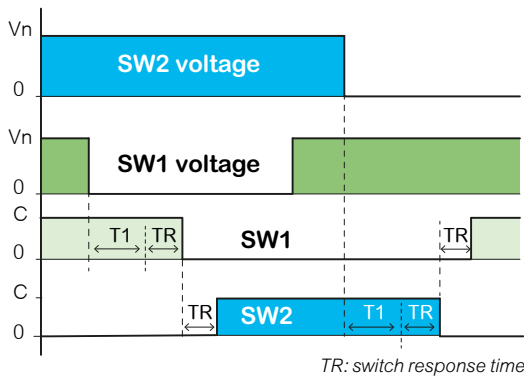

DM110122
Generator ATS - Auto SW mode
(without paralleling upon automatic return)

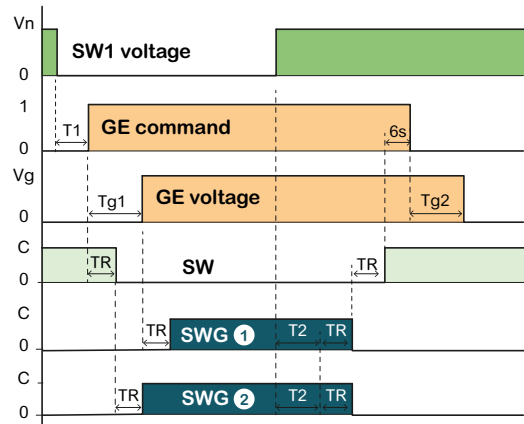

Case ①: Generator channel closing after Generator power on (configurable option).

Case ②: Generator channel closing after Generator startup command (configurable option).

TR: switch response time.
Tg1: Generator starting time (maximum 60 s).
Tg2: Generator stopping time.

ATS automatic transfer system (source changeover)

Operating modes:

The operating mode is selected from the T300 Web server.

- **No Return S1 -> S2 or S2 -> S1 mode (or Sx -> SG, if Generator ATS):**
The automatic transfer system executes only one changeover from the priority channel to the back-up channel. The automatic transfer system then remains on that channel.
- **Auto-return S1 <-> S2 mode (or Sx <-> SG, if Generator ATS):**
In the event of a voltage loss on the active channel, the automatic transfer system switches to the other channel after a time delay T1. The automatic transfer system executes no return, except in the event of voltage loss on the new active channel.
- **Self-return mode S1 -> S2 -> S1 (or Self-return Sx, if Generator ATS):**
After a changeover, return to the priority channel occurs if the MV voltage on that channel is restored. The channel that has priority can be defined according to the state of a dedicated digital input.

Changeover sequences:

- **Network ATS:** in the event of voltage loss on the normal channel, changeover involves opening the normal channel after time delay T1 and then closing the backup channel.
Note: In 'Self return' mode, the sequence of return to the normal channel depends on the configuration of the 'Enable parallel transfer mode' option (see below).
- **Generator ATS:** in the event of voltage loss on the network channel, changeover involves sending the order for opening the network channel and at the same time the Generator start-up order, after time delay T1.
The remainder of the changeover sequence depends on the management of Generator channel closing:
 - Case of Generator channel closing after start-up order:
After the Generator start-up order, the closing order is given to the Generator channel, without waiting until the Generator is actually started.
 - Case of Generator closing after Generator power on:
The Generator channel closing order is sent only when Generator voltage is detected.

Remark: some functionalities regarding Generator ATS automation might be different from what is described globally in this document. It depends on how it has been implemented or personalized in the T300 programmable platform (PowerLogic Builder). Consult us to obtain the T300 application note describing how to set the Network ATS and the Generator ATS automations.

Configurable parameters:

- Automatic transfer system ON/OFF.
- Operating mode: Self-return S1 -> S2 -> S1, Auto-return S1<> S2, No-return S1 -> S2 or S2 -> S1.
- T1: 0 ms to 2 min. in increments of 1 ms.
- T2: 0 to 30 sec in increments of 1 ms
- Blocking transfer upon fault detection.
- Choice of voltage presence detection: SC150 Voltage measurement or digital Input (i.e. DI6 connected to a VD23 relay).
- Channel connected to generator: SW1 or SW2.
- Type of automatic transfer system: Network ATS or Generator ATS.
- Manual control enabled/disabled if ATS in operation.
- Paralleling enabled/disabled in auto and/or manual mode.

ATS automatic transfer system (source changeover)

Paralleling upon Auto return

A configurable option allows the automatic transfer system to disable or enable paralleling of the channels upon automatic return to the main channel (in 'Self-return' mode).

Enabling of paralleling must be confirmed by the activation of a dedicated digital input.

Paralleling disabled: Auto return to the priority channel involves opening the backup channel and, when it is open, closing the priority channel.

Paralleling enabled: Auto return to the priority channel involves first closing the priority channel and, when it is closed, opening the backup channel.

Changeover conditions

Changeover takes place if the following conditions are met:

- Automatic transfer system in operation
- Active channel open and other channel closed or Active channel closed and other channel open
- Absence of fault current on the two channels (only if locking by fault detection option activated)
- 'Transfer locking' absent
- 'Earthing switch' absent on the two channels
- MV voltage absent on the active channel
- MV voltage present on the other channel.

Return to the main channel for the 'Self-return' modes occurs if:

- The priority channel is open
- The MV voltage on the priority channel is present during time delay T2.

Detection of voltage presence

Voltage presence on a channel managing the Generator can be executed by two processes:

- By a dedicated SC150 Digital Input (DI6) connected to a voltage relay (VD23 or other)
- By the voltage measurement of SC150 module.

Source transfer locking

A dedicated HU250 digital input (DI3) allows changeover to be locked if a problem occurs on one of the devices related to the changeover. This input is generally connected to the downstream circuit breaker. Local and remote controls are no longer possible in this case.

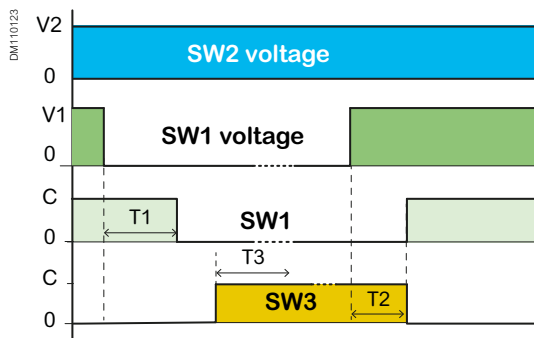
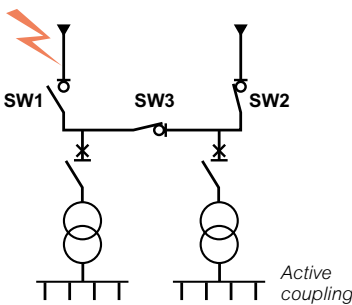
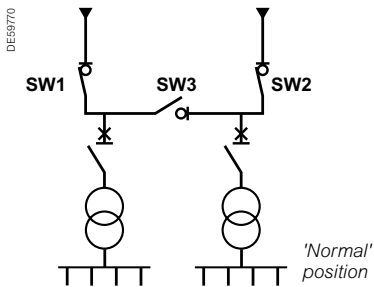

Bus tie coupling (BTA)

The BTA automation is not a preset automation systems in T300. It has been developed in the IEC 61131-3 programmable logic controller (ISaGRAF). Consult us for the availability of this program.

The BTA (Bus Tie Automatism) is an automation system for switching sources between two incoming lines (SW1 and SW2) and a busbar coupling switch (SW3). It is based on the voltage presence detectors of the SC150 module and the MV overcurrent fault detection function on the busbar incoming lines.

Operating mode

- **Standard mode:**
If the voltage is lost on one busbar, the automation system opens the incoming line (SW1 or SW2) and closes the coupling switch SW3. Coupling is conditional upon the absence of a fault current on the main source.
- **Interlock on loss of voltage after switching mode:**
After execution of the automation system in standard mode, the voltage presence is checked for a configurable period. If the voltage is lost during this period, the coupling switch SW3 is opened and the automation system interlocked.

Coupling sequence

Coupling takes place if the following conditions are met:

- The automation system is switched on
- The switches on incoming channels SW1 and SW2 are closed
- The earthing switches SW1, SW2 and SW3 are open
- There is no voltage on an incoming line SW1 or SW2
- There is no fault current detection on SW1 and SW2
- There is no transfer interlock
- Voltage is present on the other incoming line.

The coupling sequence in standard mode is as follows:

- Opening of the de-energized incoming line switch after a delay T1
- Closing of the coupling switch SW3.

The coupling sequence in 'Interlock on loss of voltage after coupling' mode is completed as follows:

- Monitoring of the voltage stability for a delay T3
- Opening of the coupling switch SW3 if this condition is not met
- Locking of BTA automation system.

The system returns to standard mode after coupling if:

- The 'return to SW1 or SW2' option is activated
- Voltage on the channel has been normal for a delay T2
- The automation system is activated
- The automation system is not locked
- There is no coupling interlock.

Monitoring & control

PowerLogic T300 Automation systems

Coupling interlock

A dedicated digital input allows changeover to be locked if a problem occurs on one of the devices related to the changeover. This input is generally connected to the downstream circuit breaker. Local and remote controls are no longer possible in this case.

Locking the automation system

The BTA automation system is locked if one of the following conditions is met during the coupling process:

- Failure of a command to open or close a switch
- Indication that an earthing switch has closed
- Appearance of a fault current
- Switch power supply fault
- Appearance of the coupling interlock
- Manual or remote ON/OFF command from the automation system.

Paralleling upon Auto return

A configurable option allows the automation system to disable or enable paralleling of the channels upon automatic return to the main channel (in 'Auto' mode).

Enabling of paralleling must be confirmed by the activation of a dedicated digital input.

- **If paralleling is disabled:** Auto return to the normal channel involves opening the coupling channel (SW3) and, when it is open, closing the normal channel.
- **If paralleling is enabled:** Auto return to the normal channel involves first closing the normal channel and, when it is closed, opening the coupling channel (SW3).

Remark: the functionality and the options of the BTA automation described in this chapter correspond to the theoretical use of the BTA function. It depends on the way it has been implemented or personalized in the IEC 61131-3 program.

The power connections in the Medium Voltage products are one of the most critical points of the substations especially for those made on site such as:

- MV cable connections.
- MV bus bar and transformer connections.
- LV transformer and switchboard connections.

Loose and bad connections cause an increase of resistance in localized points that will lead to thermal runaway leading to the complete failure of the connections.

Preventive maintenance can be complicated in severe operating conditions due to limited accessibility and visibility of the contacts.

Continuous thermal monitoring is the most appropriate and timely way to detect a compromised connection.

PowerLogic T300 measures several temperature and environmental parameters to optimize the effective life of customer assets located inside secondary MV/LV substations, using **wireless (TH110, CL110) and wired sensors (PT100)**.

These sensors, using Zigbee Green Power communication protocol, are connected to PowerLogic T300 which harvests the data for local and remote signaling, data storage for post analysis and local display.



This remote monitoring and alarming aids peace of mind thanks to remote connection to SCADA or Services platform.

Thermal monitoring

PowerLogic Thermal Sensor TH110, self-powered sensor, enables the continuous thermal monitoring of all the critical connections in the MV and LV side of the substation.

TH110 sensors linked to T300 with specific monitoring algorithms allow detection of temperature drifts. Thresholds to identify significant drifts are based on the specific installation characteristics, also taking into account the variable loads.

Algorithms also detect abnormal behaviors by comparing temperatures on the various phases.

Environment	Thermal
 <p>PM109828 PowerLogic CL110 PN: 130728</p>	 <p>PM109830 PowerLogic TH110 PN: 097742</p>
<p>CL110</p> <p>Temperature and humidity sensors measure condensation, enabling detection of local conditions where fast aging may occur.</p>	<p>TH110</p> <p>Sensors detect hotspots at cable connections which require maintenance, enabling users to take preventive action.</p>

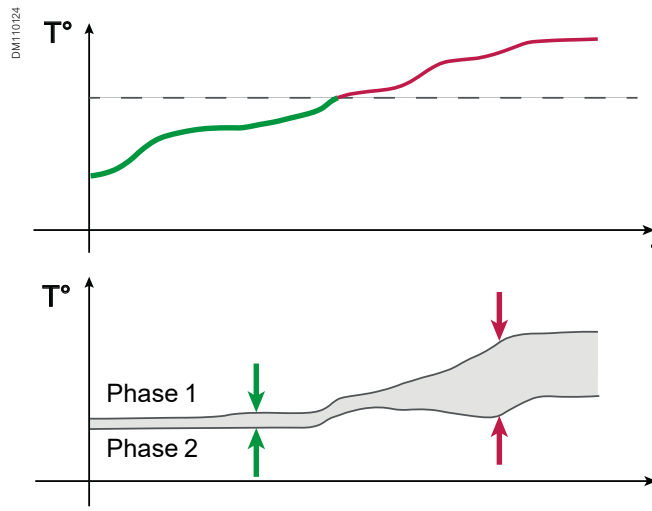

		Pollution	
		PL	PH
Condensation	Co	Degree 0	Degree 1
	CL	Degree 1	Degree 2
	CH	Degree 2	Degree 3
	CH+	Degree 3	

Pollution level according to IEC 62271-30

Environmental monitoring

CL110 wireless sensors located inside the MV switchgear compartment measure humidity, ambient, and cold point temperature. From these data, an PowerLogic T300 algorithm determines the presence of condensation then calculates the current degree of environmental safety among four possible alternatives, based on measurements and pollution level inputs according to IEC 62271-30.

PowerLogic T300 provides alarms for excessively high T°, low T°, and humidity.

Back-up solution for MV switchgear power needs in the event of micro outages and power interruptions.

- Easy maintenance with only one battery.
- Remote battery monitoring.
- High level of insulation to protect the electronic devices in severe MV environments.
- End-of-life alarm possible via Modbus communication.
- Compliant with standard IEC 60255-5 (10 kV level).

PS100 backup power supply for MV substations



Applications

The power supply unit supplies backup operating power for:

- MV switchgear motor mechanisms and circuit breaker coils
- Transmission equipment (e.g. radio)
- Control units such as RTU or Automatic Transfer System
- Protection relays, Fault Passage Indicators and others electronic devices.

Benefits

Only one battery

Traditional backup power supplies require a set of two or four batteries to produce 24 V or 48 V, which complicates replacement and adjustment of the battery pack.

The PS100 needs only one battery, simplifying replacement.

The battery is a standard sealed lead-acid 12 V battery with a 10-year service life. It can be purchased easily, anywhere in the world.

Improved availability of MV/LV substations

The PS100 is designed to cater for power network interruptions of up to 48 hours. It is associated with a battery selected to meet the required backup time.

The PS100 helps protect and optimizes the battery with state-of-the-art monitoring.

A Modbus communication port forwards monitoring data to allow optimized maintenance operations.

Outstanding integration with the PowerLogic range to control and monitor your distribution network.

Additional energy backup

The PS100 stops supplying power and reserves an 'additional energy backup' to restart the installation after an extended power interruption.

The 'additional energy backup' can be enabled with a local pushbutton to provide energy for restarting the protection relays and operating the MV switchgear.

Withstands severe substation environments

The PS100 includes 10 kV insulation, electronic protection against overvoltage and overloads, and automatic restart after a fault.

High availability power supply

A battery helps ensure uninterrupted operation of the whole substation in the event of loss of the main supply. The back-up power supply unit:

- Includes a regulated and temperature-compensated charger
- Stops the battery before deep discharge
- Carries out a battery check every 12 hours
- Measures battery ageing
- Forwards monitoring information via a Modbus communication port and output relays

Main features

- DIN rail mounting for easy integration in any LV cabinet or MV/LV substation
- Two power supply outputs:
 - 12 Vdc - 18 W continuous - 100 W 20 s (for modem, radio, RTU, etc.)
 - 48 Vdc or 24 Vdc - 300 W / 1 minute (for switchgear operating mechanism motors) and 90 W / continuous for protection relays, electronic devices, etc
- RJ45 Modbus communication port
- Two output relays (AC supply ON, Battery ON)
- Diagnosis with LEDs
- One sealed lead-acid 12 V battery with a 10-year service life (from 7 Ah to 40 Ah)
- Power supply paralleling available with a 2nd PS100
- -40 °C to +70 °C operating temperature.

Range

- PS100-48 V 48 Vdc power supply and battery charger.
- PS100-24 V 24 Vdc power supply and battery charger.
- Bat24AH 24 Ah long life battery.
- Bat38AH 38 Ah long life battery.

Installation and connection

Connections with dry-type cables	99
Selection table	99
Cable connection from below	101
Cable positions	101
Trench depths	102
Trench diagrams examples	103
Dimensions and weights - Basic	105
Dimensions and weights - Advance	106
Civil engineering	107
Layout examples for SM AirSeT	108

Connections with dry-type cables

Selection table

- Access to the compartment is interlocked with the closing of the earthing switch.
- The reduced cubicle depth makes it easier to connect all phases.
- A 12 mm Ø pin integrated with the field distributor enables the cable end terminal to be positioned and attached with one hand. Use a torque wrench set to 50 Nm.



Round connector



Square connector

The ageing resistance of the equipment in an MV/LV substation depends on three key factors:

- **The need to make connections correctly**
New cold fitted connection technologies offer ease of installation that favours resistance over time. Their design enables operation in polluted environments under severe conditions.
- **The impact of the relative humidity factor**
The inclusion of a heating element is essential in climates with high humidity levels and with high temperature differentials.
- **Ventilation control**
The dimension of the grills must be appropriate for the power dissipated in the substation. They must only traverse the transformer area.

Network cables are connected:

- On the switch terminals
- On the lower fuse holders
- On the circuit breaker connectors.

The bimetallic cable end terminals are:

- Round connection and shank for cables $\leq 240 \text{ mm}^2$
- Square connection round shank for cables $> 240 \text{ mm}^2$ only
- Crimping of cable end terminals to cables must be carried out by stamping.

The end connectors are of cold fitted type

Schneider Electric's experience has led it to favor this technology wherever possible for better resistance over time.

The maximum admissible cable cross section:

- 630 mm^2 for 1250 A incomer and feeder cubicles
- 240 mm^2 for 400-630 A incomer and feeder cubicles
- 120 mm^2 for contactor cubicles
- 95 mm^2 for transformer protection cubicles with fuses.

Connections with dry-type cables

Selection table

Dry-type single-core cable

Short inner end, cold fitted

Performance	Cable end terminal type	X-section mm ²	Supplier	Number of cables	Comments
3 to 24 kV 400 A - 630 A	Round connector	50 to 240 mm ²	All cold fitted cable end suppliers: Silec, 3M, Pirelli, Raychem, etc.	1 or 2 per phase	For larger x-sections, more cables and other types of cable end terminals, please consult us
3 to 24 kV 1250 A	Round connector	50 to 630 mm ²	All cold fitted cable end suppliers: Silec, 3M, Pirelli, Raychem, etc.	1 or 2 per phase ≤ 400 mm ²	For larger x-sections, more cables and other types of cable end terminals, please consult us
	Square connector	> 300 mm ² admissible		400 < 1 ≤ 630 mm ² per phase	

Three core, dry cable

Short inner end, cold fitted

Performance	Cable end terminal type	X-section mm ²	Supplier	Number of cables	Comments
3 to 24 kV 400 A - 630 A	Round connector	50 to 240 mm ²	All cold fitted cable end suppliers: Silec, 3M, Pirelli, Raychem, etc.	1 per phase	For larger x-sections, more cables and other types of cable end terminals, please consult us
3 to 24 kV 1250 A	Round connector	50 to 630 mm ²	All cold fitted cable end suppliers: Silec, 3M, Pirelli, Raychem, etc.	1 per phase	For larger x-sections, more cables and other types of cable end terminals, please consult us

Note:

- The cable end terminals, covered by a field distributor, can be square,
- PMI/QM type cubicle, round end connections Ø 30 mm max.

Cable connection from below

Cable positions

Cable-connection height H measured from floor (mm)

	630 A	1250 A
IM, NSM-cables	945	
SM	945	945
IMC	400	
PM, QM	400	
QMC	400	
DMVL-A	430	320 ⁽¹⁾
DMVL-W	430	
GAM2	760	
GAM ⁽¹⁾	470	620

(1) Coming H1/2025.

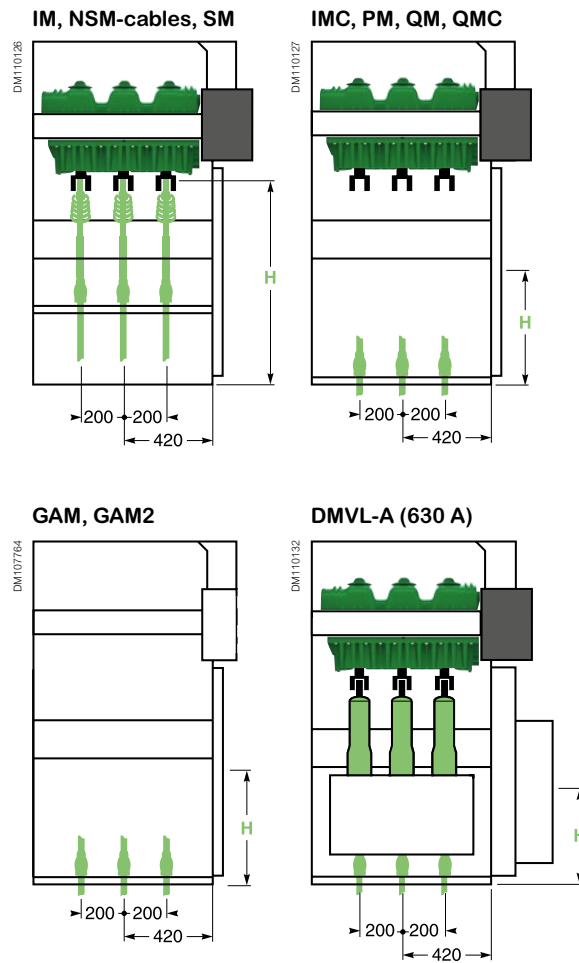

- X = 330: 1 single-core cable
- X = 268: 2 single-core cables
- X = 299: 1 three core cable

Cable connection from below

Trench depths

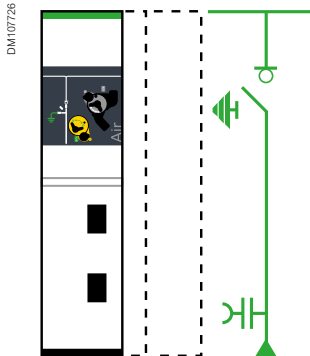

Basic cubicle for internal arc 12.5 kA 1s, IAC: A-FL

- **Through trenches:** depth **P** of trench for commonly used dry single-core cables (for 3P cables, contact Schneider Electric)
- **With raised base:** to reduce **P** or avoid trenches, cubicles can be placed on 400 mm concrete bases
- **With crawl space:** depth **P** for commonly used cable types.

1P cables	Cubicle up to 630 A		
Cable cross-section (S)	IM, NSM, GAM2	IMC, DMVL-A, DMVL-S	PM, QM
	Trench depth P (mm)		
$S \leq 95$	160	470	350
$95 < S \leq 120$	200	500	
$120 < S \leq 240$	330	730	

Chamfer (C) ⁽¹⁾	Dimension (mm)	
C	75	150

(1) In case of cable entry from rear or front.

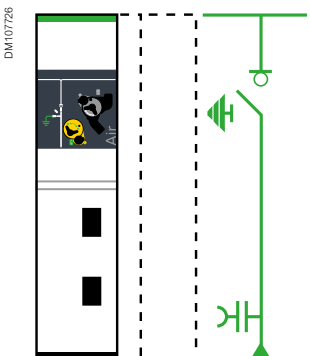

Advance cubicle for internal arc 12.5 kA 1s, IAC: A-FLR, 16 and 20 kA 1s, IAC: A-FL/A-FLR

- **Through trenches:** the trench depth **P** is given in the following table for usual dry single-core cables type (for tri-core cables consult us).
- **With stands:** to reduce **P** or avoid trenches, by placing the units on 400 mm concrete footings.
- **With floor void:** the trench depth **P** is given in the following table for usual types of cables.

Cable section (mm ²)	IAC (kA/1s)	DMVL-A		All other cubicles (except DMVLA)	
		12.5	16	12.5	16
		$S < 120$	330	550	330
$120 < S < 240$	330	550	450 Cables coming under the circuit breaker	330	550
	Cables coming other side of the circuit breaker				

Note: The unit and the cables requiring the greatest depth must be taken into account when determining the depth **P** for single-trench installations. In double-trench installations, depth **P** must be taken into account for each type of unit and cable orientations.

For internal arc 12.5 kA 1s, IAC: A-FL

Units represented without switchboard side panels

630 A units

Incomer or Feeder via
the Rear with Nozzles

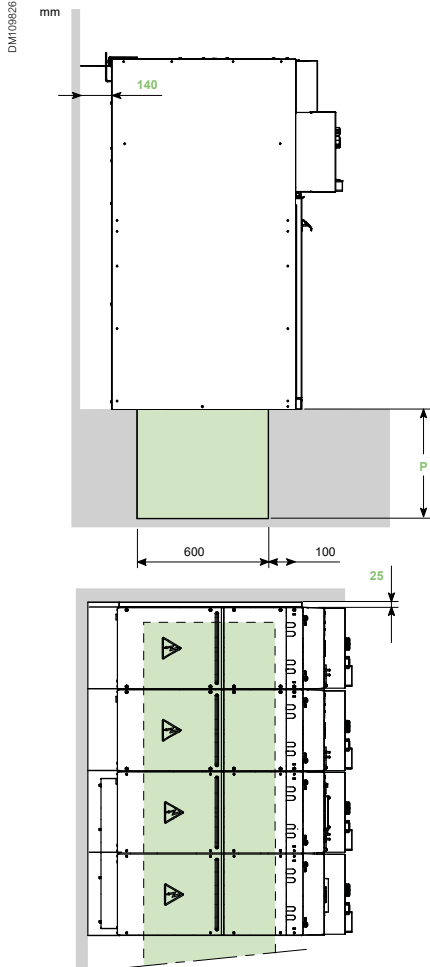

Incomer or Feeder via
Left or Right Side

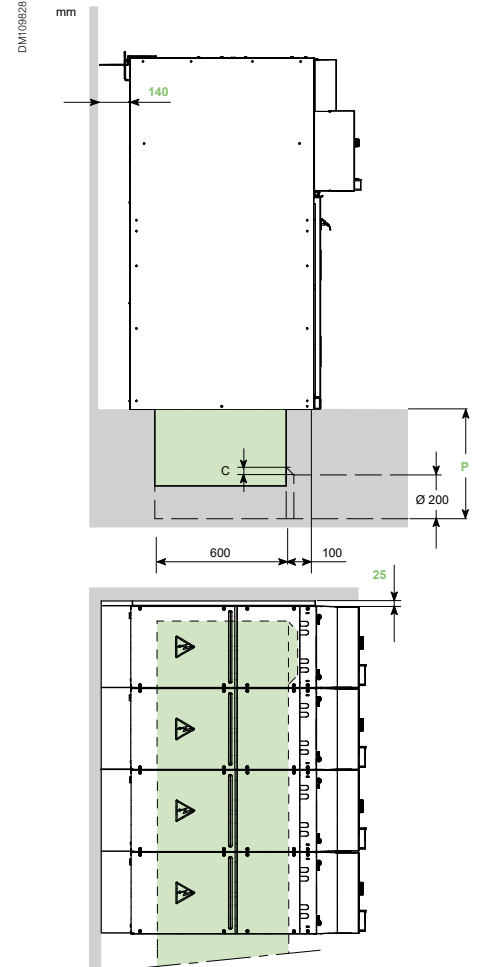
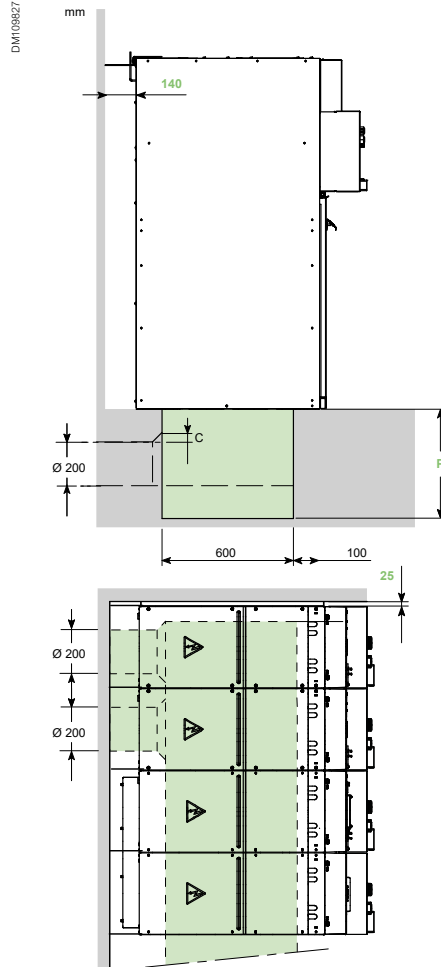

Required dimensions (mm)

For detail, please check with civil engineering guide

For internal arc
12.5 kA 1s, IAC: A-FLR,
16 and 20 kA 1s, IAC: A-FL/A-FLR

Units represented without switchboard side panels

630 A units
Cable entry or exit
through right or left side

630 A units
Rear entry or exit
with conduits

630 A units
Front entry or exit
with conduits

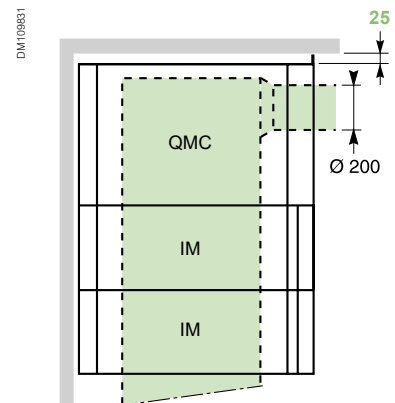
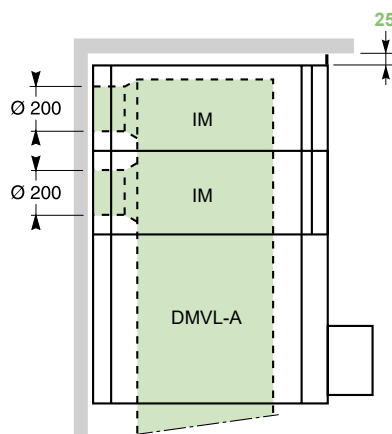
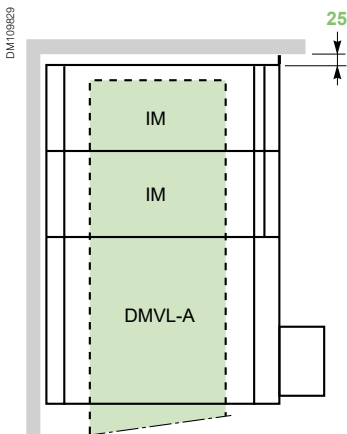
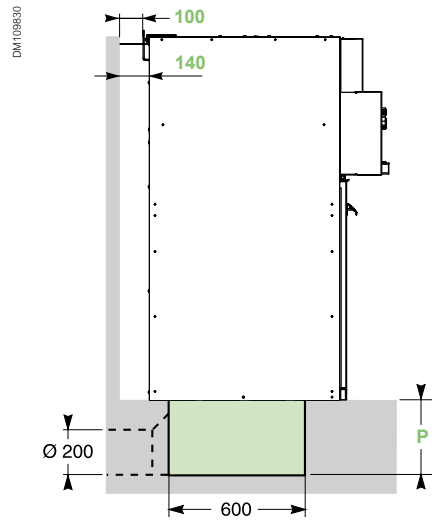

Required dimensions (mm)

For detail, please check with civil engineering guide

Dimensions and weights - Basic

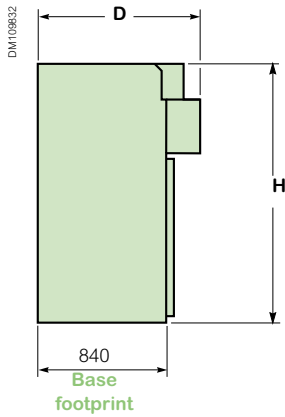

125 Wide cubicles

Unit type	Height H (mm)	Width (mm)	Depth D (mm)	Weight (kg)
GIM	1600	125	840	30

375 Wide cubicles

Unit type	Height H (mm)	Width (mm)	Depth D (mm)	Weight (kg)
IM, IMB	1600	375	1030	127
PM, QM, QMB	1600	375	1030	137
CM	1600	375	1030	197
GAM2	1600	375	1030	127
GBM	1600	375	1030	127
SM	1600	375	1030	127
TM	1600	375	1030	207

500 Wide cubicles

Unit type	Height H (mm)	Width (mm)	Depth D (mm)	Weight (kg)
IM	1600	500	1030	137
IMC	1600	500	1030	207
QM	1600	500	1030	157
CM2	1600	500	1030	217

625 Wide cubicles

Unit type	Height H (mm)	Width (mm)	Depth D (mm)	Weight (kg)
QMC	1600	625	1030	187

750 Wide cubicles

Unit type	Height H (mm)	Width (mm)	Depth D (mm)	Weight (kg)
DMVL-A/2/D/S/M	1600	750	1220	407
GBC-A, GBC-B	1600	750	1110	297
NSM-cables - NSM-busbars	2050	750	1030	267

Find more information, see installation guide.

Dimensions and weights - Advance

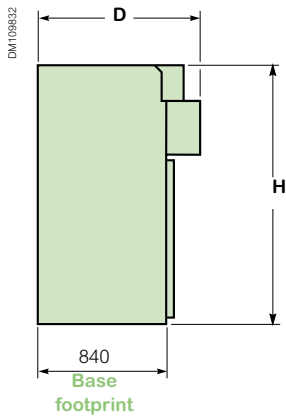

125 Wide cubicles

Unit type	Height H (mm)	Width (mm)	Depth D (mm)	Weight (kg)
GIM	1600	125	930	40

375 Wide cubicles

Unit type	Height H (mm)	Width (mm)	Depth D (mm)	Weight (kg)
IM, IMB	1600	375	1120	137
PM, QM, QMB	1600	375	1120	147
CM	1600	375	1120	207
GAM2	1600	375	1120	137
GBM	1600	375	1120	137
SM	1600	375	1120	137
TM	1600	375	1120	217

500 Wide cubicles

Unit type	Height H (mm)	Width (mm)	Depth D (mm)	Weight (kg)
IM	1600	500	1120	147
IMC	1600	500	1120	217
QM	1600	500	1120	167
CM2	1600	500	1120	227

625 Wide cubicles

Unit type	Height H (mm)	Width (mm)	Depth D (mm)	Weight (kg)
QMC	1600	625	1120	197

750 Wide cubicles

Unit type	Height H (mm)	Width (mm)	Depth D (mm)	Weight (kg)
DMVL-A/2/D/S/M	1600	750	1230	417
GBC-A, GBC-B	1600	750	1120	307
NSM-cables - NSM-busbars	2050	750	1120	277

Find more information, see installation guide.

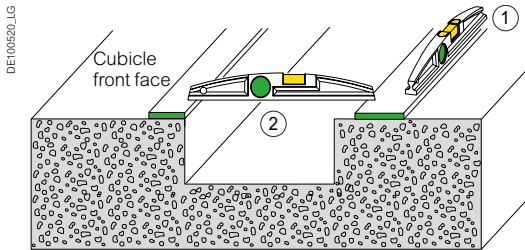

Ground preparation

To obtain the internal arc performance, ground implementation must comply with the following requirements:

- Straightness: 2 mm / 3 m (Rep.1)
- Flatness: 3 mm maximum (Rep.2)

All the elements including the evacuation of the gas (duct, casing, etc.) must be able to bear a load of 250 kg/m².

Fixing of units

With each other

The units are simply bolted together to form the MV switchboard (bolts supplied). Busbar connections are made using a torque wrench set to 28 Nm.

On the ground

- For switchboards comprising up to three units, the four corners of the switchboard must be secured to the ground using:
 - M8 bolts (not supplied) screwed into nuts set into the ground using a sealing pistol.
 - screw rods grouted into the ground.
- For switchboards comprising more than three units, each unit must be fixed to the ground.
- In circuit-breaker or contactor units, fixing devices are installed on the opposite side of the switchgear.

Position of cubicles in a substation

**Installation of a switchboard
classified IAC 12.5 kA 1s: A-FL
Conventional substation (Masonry)**

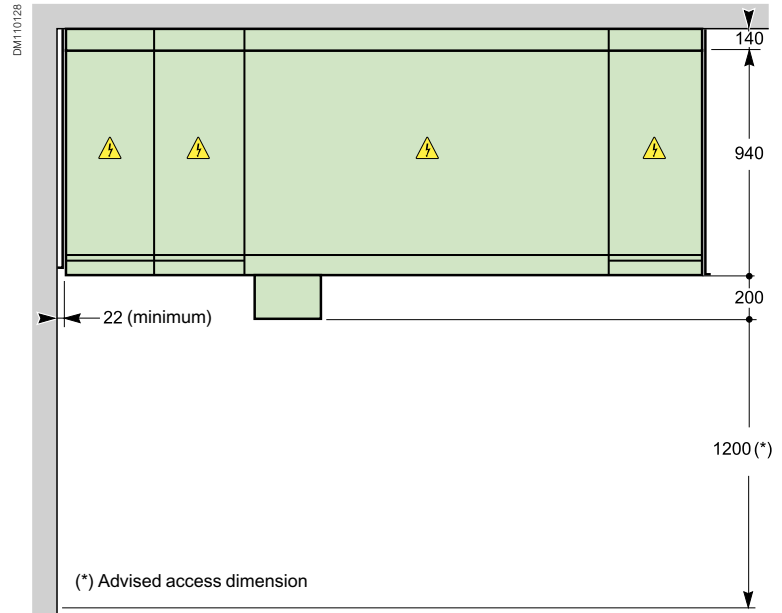

**Installation of a switchboard
classified IAC 16 kA 1s: A-FL
with downwards exhaust**

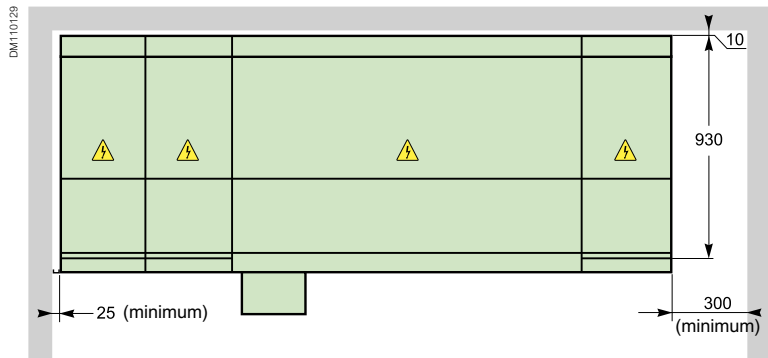

300 mm minimum required for human access for fixation of the back during installation.

**Installation of a switchboard
classified IAC 16 kA 1s: A-FLR
with downwards exhaust**

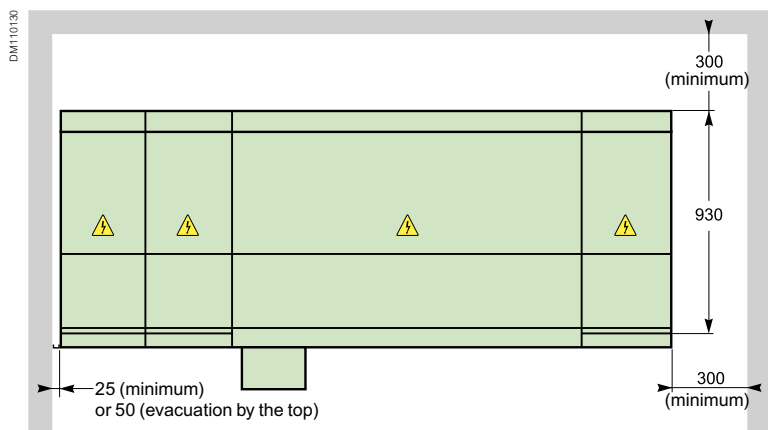

300 mm minimum required for human access for fixation of the back during installation.

Installation of a switchboard classified IAC: A-FL & A-FLR with upwards exhaust left side

(ceiling height ≥ 2150 mm)

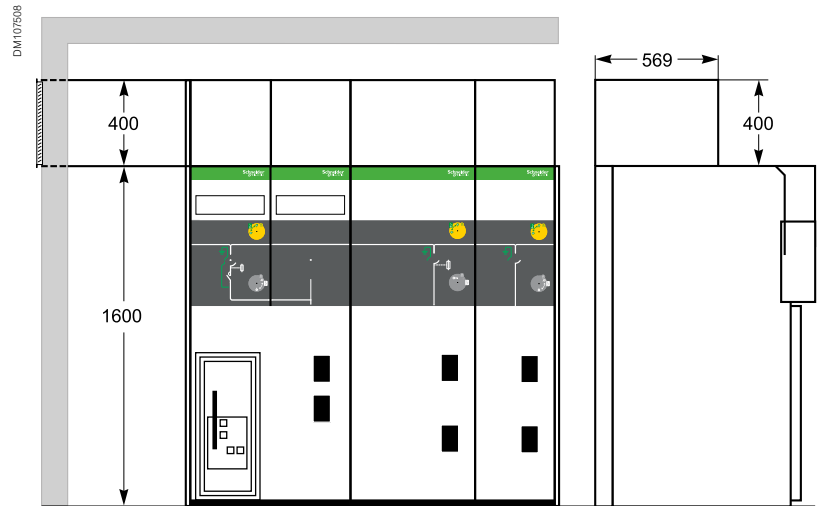

Gas exhaust duct

To enable the evacuation of gases by the top, users must install a duct fixed to the coupling flange on the right or left of the switchboard. For IP3X protection, a flap must be installed with this coupling flange on the lateral of the cubicle duct.

The end of the duct must block water, dust, moisture, and animals from entering and at the same time enable the evacuation of gases into a dedicated area through a device situated at the outer end of the duct (not supplied).

Gas exhaust duct

example:

The exhaust duct must be made of metal sheet of sufficient thickness to withstand pressure and hot gases.

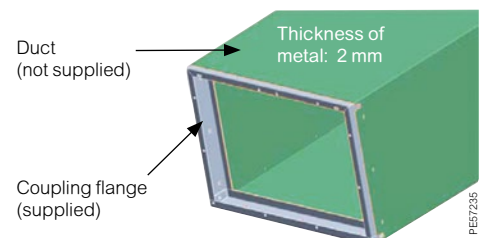

Learn more on our Medium Voltage products and technology

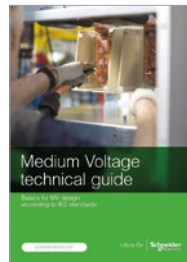

Helping you design MV products according to IEC standards

- Our talented electrical distribution experts share their industry-leading knowledge of technological developments and evolving medium-voltage standards.

[MV Technical Guide](#)

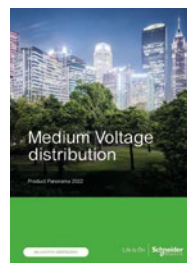

Build your MV network

- Discover Schneider Electric products and MV components for your MV network with the extensive Panorama guide.

[MV product panorama](#)



Component for MV switchgear

- A complete overview of all the components from the Schneider Electric ranges to help you to build innovative and high-quality medium-voltage switchgear.

[MV component Catalog](#)

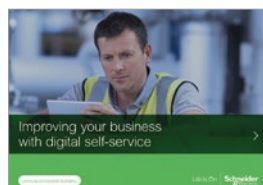

Improving your business with digital self-service

- Digital self-service helps your business improve flexibility and productivity, allowing you to quickly adapt to customer needs in changing times.

[Digital Life Cycle eGuide](#)



Learn More



How EEC Engie looks after the local ecosystem with sustainable strategy



How GreenAlp makes a city better with green innovation



How E.ON in Sweden is providing greener energy



Discover AirSeT technology



How SF₆-free and digital technologies combine for sustainability and efficiency



Renault Group's circularity on track with AirSeT

Schneider Electric

35 rue Joseph Monier
92500 Rueil-Malmaison, France
Phone: + 33 (0)1 41 29 70 00

www.se.com

Document updated 30th July 2024

©2024 Schneider Electric. All Rights Reserved. Life Is On Schneider Electric is a trademark and the property of Schneider Electric SE, its subsidiaries and affiliated companies. All other trademarks are the property of their respective owners.

NRJCAT21009EN

Life Is On

