

Panel Builders

Complete solutions for LV Panels and MV Switchgears manufacturing
2025



se.com

Life Is On



About our Company

Schneider's purpose is to create Impact by empowering all to make the most of our energy and resources, bridging progress and sustainability. At Schneider, we call this Life Is On.

Our mission is to be the trusted partner in Sustainability and Efficiency.

We are a global industrial technology leader bringing world-leading expertise in electrification, automation and digitization to smart industries, resilient infrastructure, future-proof data centers, intelligent buildings, and intuitive homes. Anchored by our deep domain expertise, we provide integrated end-to-end lifecycle AI enabled Industrial IoT solutions with connected products, automation, software and services, delivering digital twins to enable profitable growth for our customers.

We are a people company with an ecosystem of 150,000 colleagues and more than a million partners operating in over 100 countries to ensure proximity to our customers and stakeholders. We embrace diversity and inclusion in everything we do, guided by our meaningful purpose of a sustainable future for all.



Schneider Electric in figures

€36 bn
2023 revenues

150.000
employees in 100+ countries



Targets by 2025

80%
green revenue

800 million tons
of CO₂ emissions savings for our customers (since 2018)

1,000 top suppliers
to reduce CO₂ emissions by 50%

On our way to net-zero by 2030





A global program with local support:

4,500
EcoXpert Partners

80
countries

1
Worldwide Network

One program. One network. Endless opportunities. At Schneider Electric, we constantly look beyond the norm to provide innovative solutions, both in technology and in the way we do business.

That's the idea behind the EcoXpert Partner Program – a program unique in its industry, offering an esteemed partnership between Schneider Electric and a global, cross-expertise ecosystem of solution providers. Together, we deliver best-in-class automation and digital solutions for efficiency and sustainability to our customers.

Certified in EcoStruxure™ solutions, EcoXpert partners digitize and electrify our world for a more sustainable future.



Grow your business

Collaborate with Schneider Electric and the EcoXpert network for innovative solutions that win new opportunities and improve your hit rate.



Maximise your margin

Gain a competitive edge with tested, validated, and documented technologies and solutions.



Differentiate yourself

Rise above the competition with co-branding and co-marketing initiatives for business partners.



Improve employee talent

Increase retention rates and decrease the time it takes to onboard new hires through a comprehensive training and certification process.



Save time

Access the tools you need to optimize the integration of third-party systems and minimize engineering and commissioning time.



Capture new market share

Rely on the support of Schneider Electric at every turn of your expansion as a business partner.

[More information on se.com](http://se.com)

Discover the EcoXpert Certifications

Power Distribution and Management



Power Upgrade
Proven expertise in digital commissioning of connected panels and perform essential level of maintenance service.



Power Automation
Proven expertise in deploying high- and medium-voltage substation automation systems using LEDs and software tools, EPAS or Power Operation SCADA system to improve observability, controllability, and reliability of the customer's ED.



Power Distribution
Proven expertise in power distribution and motor control, manufacturing certified and smart ready, low-voltage or medium-voltage switchboards.



Power Management
Proven expertise in integration and commissioning of electrical systems to drive energy management & operational efficiency using on-premise or cloud-based solutions.



Power Services
Proven expertise in maintaining the availability and durability of electrical distribution installations with field and digital services.



Microgrid
Proven expertise in load & source management and Energy Storage management to address New Energy Landscape market needs.

Giving you more to get more done with our software and tools



Search and select



Discover our products, software and services. Select the offer that best suits you.



Explore our products for panel builders



mySchneider Panel Builder program
The program designed to help you access the resources and training you need



Find your sustainability solution



mySchneider App
Access our catalog online and offline, personalize your service and talk to our experts directly with the mySchneider app.



Schneider Electric Exchange
Find digital solutions for solving energy and automation challenges



Thermal Management - ProClima
Find the best thermal solution for your enclosure
Select and calculate your thermal management requirements according to the environment and the electrical/electronic devices installed in the enclosure.



Configure, quote and build

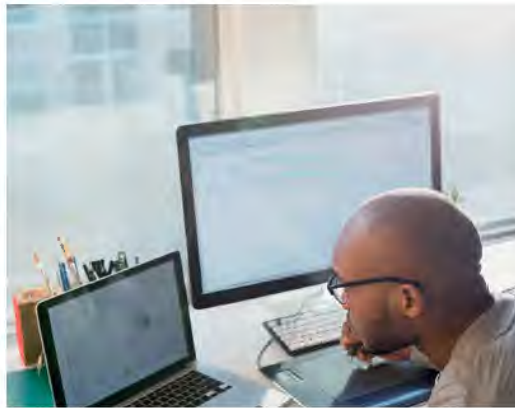

Get your quote and find your contract



SEE Electrical 3D Panel+
Design and manufacture electrical panels in 3D



EcoStruxure Power Build - Rapsody
Configuration and quotation software for PrismaSeT switchboards



EcoStruxure Power Build - Medium voltage
All-in-one online configuration and quotation software dedicated to MV switchgear



EcoStruxure Motor Control Configuration
Build your complete motor control solution for protection and control of your motors



Custom Enclosure Configurator
Get your enclosure pre-engineered for your special needs
The Custom Enclosure Configurator software gives you total autonomy to configure and quote enclosures with services (cut-outs, painting, accessory mounting) in less than 3 minutes. Custom Enclosure Configurator is designed to create orders quickly and conveniently, without any errors.



CanBrass
Design and quotation software for Canalis busbar trunking system



Where to buy ?
Find a distributor in your location



Check price and availability at mySE

Discover our program benefits, resources for your business, digital tools to help you design and build best in class equipment, and learn about our innovative offers.



Operate and maintain



Optimize



Find anything you need for the maintenance of your products



EcoStruxure Power Device app 
Single app to operate and maintain MV and LV connected devices from your mobile



EcoStruxure Power Monitoring Expert 
Power monitoring software for reliable electrical networks



EcoStruxure Energy Hub 
Software and app to help you deliver valuable services to optimize operation, comply to energy codes and monitor energy remotely in single or multi-site buildings with fast setup and end-to-end security and scale

[MORE DETAILS ON PAGE 15](#) 



EcoStruxure Power 
Discover the benefits of digitized power distribution



Facility management software 
Our comprehensive solutions to help carry out timely maintenance, manage building systems, supervise power supply systems, and optimize energy consumption.



EcoStruxure Power Advisor 
Optimize power system performance with analytics and expertise



Cybersecurity services 
Holistic cybersecurity programs to help maintain your defenses over time at your location



Improve your Engineering & Production efficiency

A dedicated software for each step

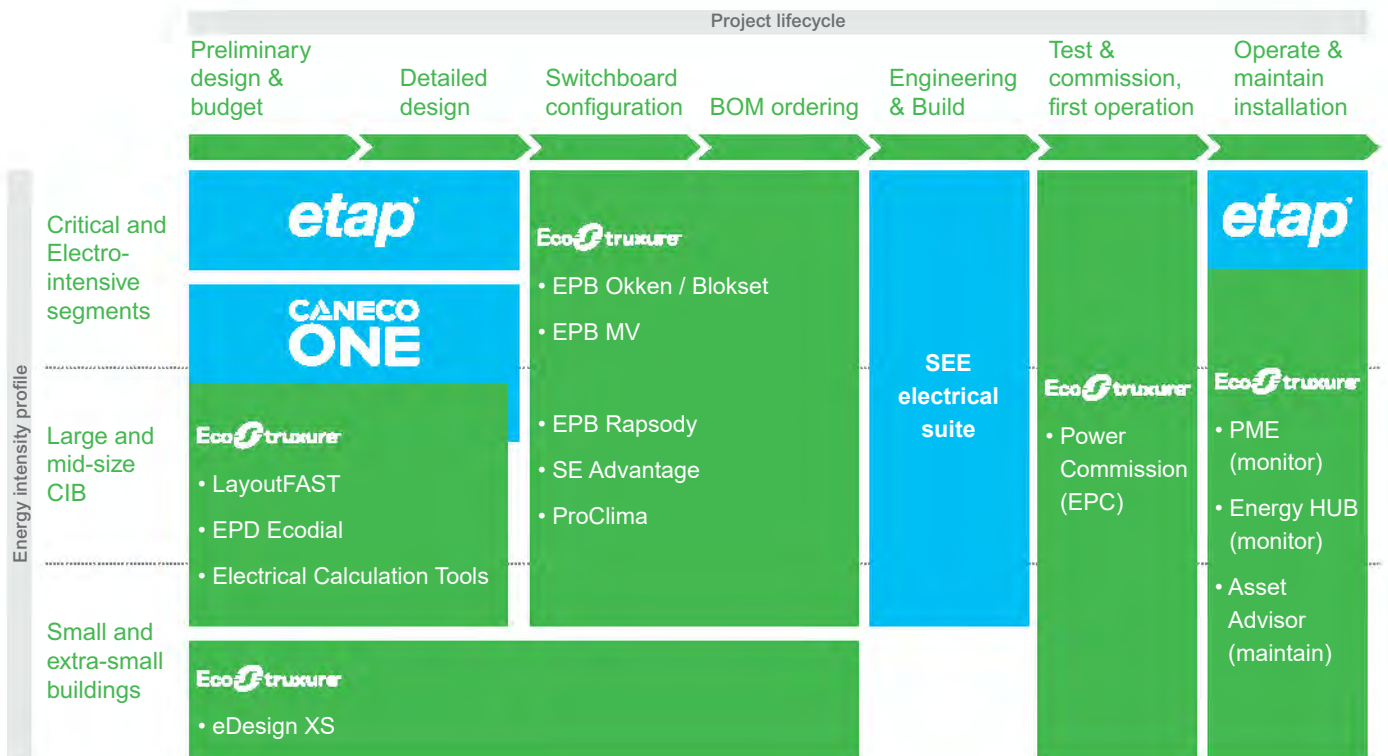

Software

Design Optimization

Caneco BT is a **software** for automated calculations, sizing, and diagrams of low voltage electrical installations.



Design optimization for Competitive alternatives

Challenge the Specs to optimize your panels and win your projects.

Service opportunities for your Customers!

Propose dimensioning Services to your customers in a hurry with a professional / Multi brand tool.

Save > 2h engineering per panel!

To transfer pre-design to your:

- Tendering Software: direct link to EPB Okken/ Blokset/MV
- Schematics/Detailed design: direct link to SEE Electrical Expert.

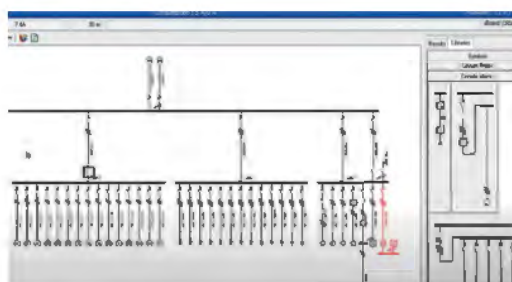
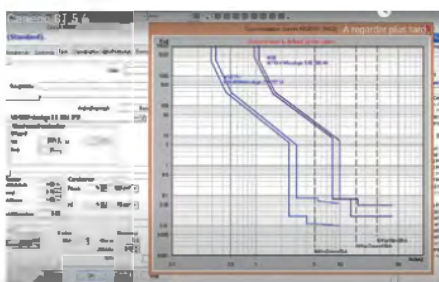

Features

Calculations and sizing

- Caneco BT performs all the calculations (Ik, du, If, ...) in compliance with the applicable standards and the electrical constraints of your installation
- It also determines the most economical equipment to protect the installation and the individuals

Discrimination and backup

- Caneco BT provides a diagnosis based on tripping curves, calculation and manufacturer tables
- It takes into account the currents, as well as the chronometrical and differential aspects to ensure discrimination that can also be reinforced by coordination

Automated diagrams

- Caneco BT automatically produces the diagrams of the electrical installation based on 3 dynamic data entry interfaces: network single-line diagram, board single-line diagram and spreadsheet

Effective data exchange

- Caneco BT allows data import/export from an Excel file
- The electrical data recovered from Revit®, is used for the automated production of the diagrams and the integration of the circuit data into Caneco BT
- Caneco BT converts the diagrams and the technical documentation of the project into a dxf file (an AutoCAD® file)



[Click here for more information](#)

Switchboard configuration and quotation Efficiency

EcoStruxure Power Build Rapsody

Configuration and quotation software for Schneider Electric LV & MV cubicles

Software supporting panel builders and electrical contractors, all across configuration and quotation of power distribution switchboard



Reduce your quotation time!

- <1h per panel thanks to intuitive interface and project libraries
- Direct links to your pricing software.

Professional tendering documents

- Realistic 2D Front/Side/Top views
- Main Electrical & Mechanical BOM.

Reduce quotation risks!

> 95% accuracy.

Save > 2h engineering per panel !

To transfer tendering data to your Schematics/ Detailed design:

- Direct link EPB MV/LV → SEE Electrical Expert.

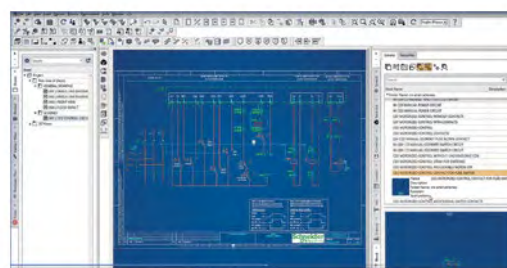

Features

You can find different version depending of the Switchboard offer or Country of commercialization as.

- EcoStruxure Power Build – Rapsody for PrismaSeT Low Voltage Switchboard in Western Europe
- EcoStruxure Power Build – MV for all Medium Voltage Switchboard
- EcoStruxure Power Build – Okken/Blokset for Okken & Blokset Low Voltage Switchboard
- EcoStruxure Power Build – easyprisma for PrismaSeT international Low Voltage Switchboards.



Click here for more information

Engineering Efficiency

SEE Electrical

Electrical CAD software for creating wiring diagrams in a few clicks

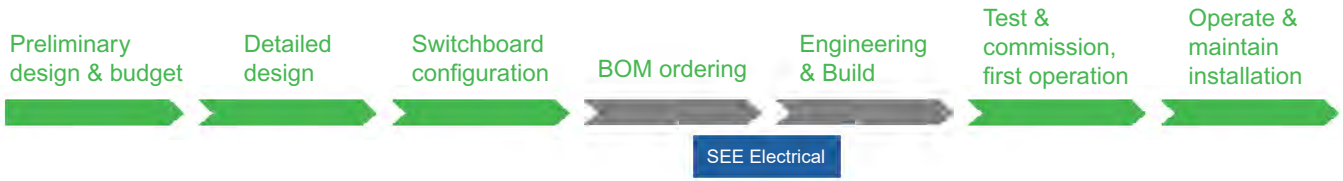

Reduce drastically your engineering time!

>50% vs mechanical CAD (AutoCAD,...) thanks to electrical functions automation (cross refs, checks,...).

Quality - Error-free design

Eliminate many of the errors caused by repetitive manual tasks.

Saving set-up time

With >1 Million Multi-brand database:

- Schneider Electric LV/MV full database with >100k articles.

Forget dedicated workers for label production!

Direct export from Schematics to printers and engraving machines

- To cancel typing errors
- To save drastically time to prepare stickers, labels, etc.



Exports to Production process made so easy!

Fully customizable reports for production available in a mouse-click

- Cables lists with connection information
- Material lists with label information
- ...

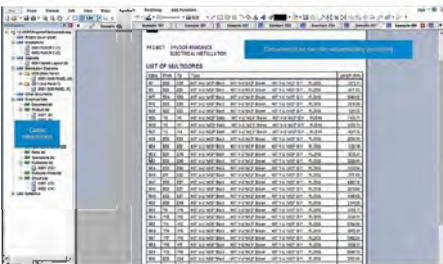

Features

- Editable hardware database (manually or via file imports) with over 1 million references
- Real-time editing of material lists
- Synchronisation of PLC card attributes in real time
- Increase the legibility and quality of your documents (generation of graphic terminal block plans, automatic wire numbering according to different formats, orientation of connections, hierarchisation of folders according to the functions and locations of your components, etc.)
- Reduction in the number of errors



[Click here for more information](#)

Software

Production Efficiency to next level

SEE Electrical 3D Panel + / SEE Electrical 3D Shop Floor

3D Panel+ bridges the gap between the schematic and the manufacturing of the electrical cabinet.

SEE Electrical 3D Shop Floor: a mounting and wiring assistant dedicated to shop floors.

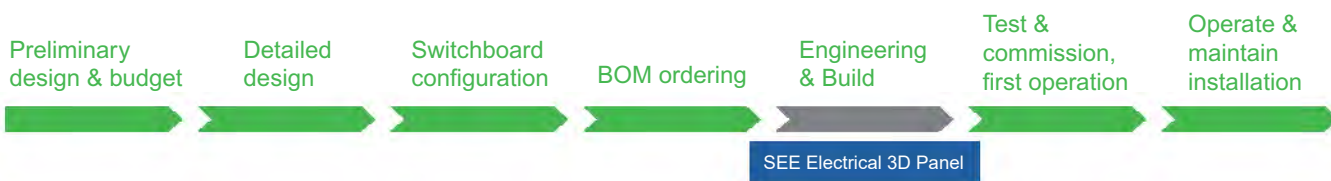

Anticipate collisions with 3D

Doors, Busbars, ..., on complex panels.

Save time & errors for doors, plates and busbars

Drillings & cuttings

- Export perfect plans to to CNC machines (Steinhauer,..).



80% cabling time reduced!

Thanks to **automatic wire routing and wire calculation** in 3D & direct import in Cable preparation machines (Komax, ...).

Mounting & wiring learned in no more than 15 min!

Fully guided step by step mounting & wiring instructions on a 3D digital twin.

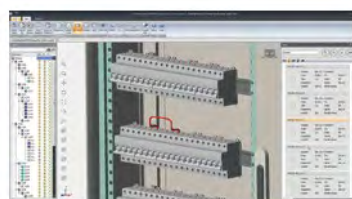
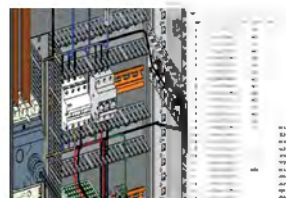

Features: 3D panel +

Electrically enabled 3D Engine

- Intelligent snapping system for components and enclosures
- Wire, net, cable routing and optimal length management algorithm
- Mechanical collision and Channel filling check
- STEP import/export with mechanical CAD software

Ready for manufacturing

- Mechanical processing data export
- Wire processing data export

Features: 3D panel Shop Floor

- Clear view on devices which need to be mounted and on their position
- Wire list provides clear information on involved devices and route to take
- Selected devices are highlighted and user can validate the mounting with a finger touch
- User can select wire in the list with mouse, finger or even by flashing barcodes engraved on wires
- Possible to filter by device, color, wire size, etc.



Click here for more information

Efficient Tests & Easy to build Digital Twin

EcoStruxure Power Commission



Reduce your Communication testing time!

Automatic devices recognition & test report generated automatically.

Service opportunities to End User through Digital Twin!

- Create your full panel document on-line in a few mouse-clicks

One tool for all devices settings!

Breakers & communication settings easily done & stored.

Easy access & update of panel technical data through a digital logbook

Easy access & update on the field for the maintenance teams.

EcoStruxure



Features

Easy setup

- Discover all the smart devices in your electrical panel
- Easily check firmware compatibility to install upgrades as required
- View communication architecture to adjust communication settings
- Get the complete list of devices in the switchboard to configure electrical settings for breakers and meters

Reliable testing

- Easily test the communication wiring, troubleshoot issues, and generate reports as part of the Factory Acceptance Tests (FAT) or Site Acceptance Tests (SAT)
- Test Low voltage circuit breakers and their trip curve behavior during installation and maintenance and generate a report (paid feature).

Fast commissioning

- Generate a comprehensive project report that lists your switchboard and related devices, firmware version, and serial numbers.
- Use batch operations feature to speed up settings configuration for several devices at the same time (paid feature)

Digital collaboration

- Create a unique QR code for your switchboard and upload relevant documentation, including important CAD drawings, user guides, bills of materials, single line diagrams, and photos, to our secure cloud repository.
- Effortlessly initiate preventive maintenance plans by simply exporting your data to the digital logbook feature in EcoStruxure Facility Expert, our cloud-based software for facility and building management.
- The digital logbook functionality simplifies the project handover, enables faster and easier access to historical information and collaboration with all project partners

 [Click here for more information](#)

Software

EcoStruxure™ Energy Hub

Cloud-based building energy management software

Achieve your business and sustainability goals with energy management software uniquely designed for buildings. Simply connect your energy systems and gain insights to conserve energy, reduce costs, and increase.

Energy management made simple

EcoStruxure Energy Hub is a cloud-based energy management software-as-a-service that is easy to implement and requires minimal up-front investment. Whether you need to monitor a single building or a portfolio of buildings, it enables you to instantly access your data from anywhere. Designed for commercial, industrial, and institutional buildings, it simplifies energy management across the operational lifecycle and helps you achieve your sustainability goals.



Benefits of EcoStruxure Energy Hub



Simple



Smart



IT-friendly



Cyber-resilient

Features



Monitor energy according to building codes

Building codes are now mandating energy usage be measured, stored, and visualized.

Use EcoStruxure Energy Hub to:

- Monitor and report on energy usage by building energy codes and standards
- Collect energy data by load type
- Store energy data for 36 months or more



Analyze energy usage and reduce waste

Gain energy awareness and analyze usage to drive building energy performance.

Use EcoStruxure Energy Hub to:

- Track usage by load type (HVAC, lighting, and plug loads)
- Aggregate and benchmark energy by site, building, floor, area, and zones
- Report energy usage monthly, daily, and hourly
- Energy usage comparison and analytics for common energy drivers (building area, period-over-period, outdoor temperature, and more)

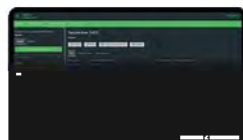

Configure and generate tenant energy bills

Compare energy usage across a portfolio of buildings and prioritize energy conservation measures.

Use EcoStruxure Energy Hub to:

- Configure simple energy rates to calculate internal energy costs
- Allocate energy usage and costs to building tenants or departments
- Generate energy bills and export to PDF for easy tenant invoicing



Monitor the status of electrical equipment

See how your electrical system is performing and get live power equipment status.

Use EcoStruxure Energy Hub to:

- View the status of the electrical network on the single-line diagram
- View, investigate and acknowledge alarms with native iOS and Android apps
- Receive alarm notifications by mobile app or email

[Learn more](#)

Zeigo™ Activate

Carbon reduction software simplified

An intuitive decarbonization solution to help you set goals, track your progress, and reduce emissions

Small and medium-sized enterprises



Track, analyze, and reduce your carbon emissions

Our carbon reduction software gives you access to resources for calculating and tracking energy-related emissions so you can put your sustainability ambitions into action. Receive a customizable decarbonization roadmap. Connect to a network of regional solution providers in energy efficiency, renewable energy, and carbon offsets.

Large corporate enterprises



Reduce Scope 3 emissions by engaging your supply chain

Resources that empower your value chain to track and reduce their carbon emissions. Tools that enable your supply chain to drive their own decarbonization program. Follow progress using Zeigo Hub, a decarbonization program designed to support supply chains in their decarbonization journey.

Measure



Calculate, measure, and analyze

Our guided setup will help you calculate, measure, and analyze your organization's emissions from all possible sources to see your current carbon footprint.

Streamline



Calculate, measure, and analyze

Our guided setup will help you calculate, measure, and analyze your organization's emissions from all possible sources to see your current carbon footprint.

Connect



Calculate, measure, and analyze

Our guided setup will help you calculate, measure, and analyze your organization's emissions from all possible sources to see your current carbon footprint.

Report

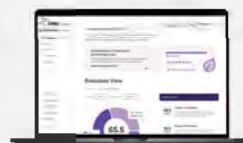

Calculate, measure, and analyze

Our guided setup will help you calculate, measure, and analyze your organization's emissions from all possible sources to see your current carbon footprint.

Software

Zeigo™ Activate

Solution providers



Join our marketplace to connect with customers in your area

Zeigo Activate is looking for solution providers, electrical contractors, system integrators, panel builders, and more to become a part of our open marketplace. When you join the Zeigo Activate marketplace, you'll receive access to potential customers who are ready to take on their next project.

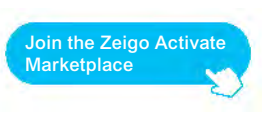

Join



Become a member of our marketplace

Get in touch with customers in your area by becoming a member of our open marketplace.

Connect



Meet with customers who are looking for experts

Find new business opportunities with potential customers who need help reaching their targets.

Share







Display your expertise

Showcase your skillset with companies looking for ways to become more efficient and reduce emissions.

About mySchneider app

Discover our new mySchneider app which offers tailored services, 24/7 self-service, and easy access to expert support and information. Download and register now to get access to recommended services and more.

✓ Top features at a glance

-  **Access the Schneider Electric catalog on your device** to see our complete range of offers, including public prices, FAQs, documents and more.
-  **Register in the app to receive real-time notifications** on updated technical documents, product news, and more.
-  **Find product information** by using the built-in barcode/QR code scanner to save time.
-  **Bypass long automated prompts:** access key contact numbers through a call menu with one, simple tap.
-  **Find the nearest distributor** to help you get Schneider Electric product right away.

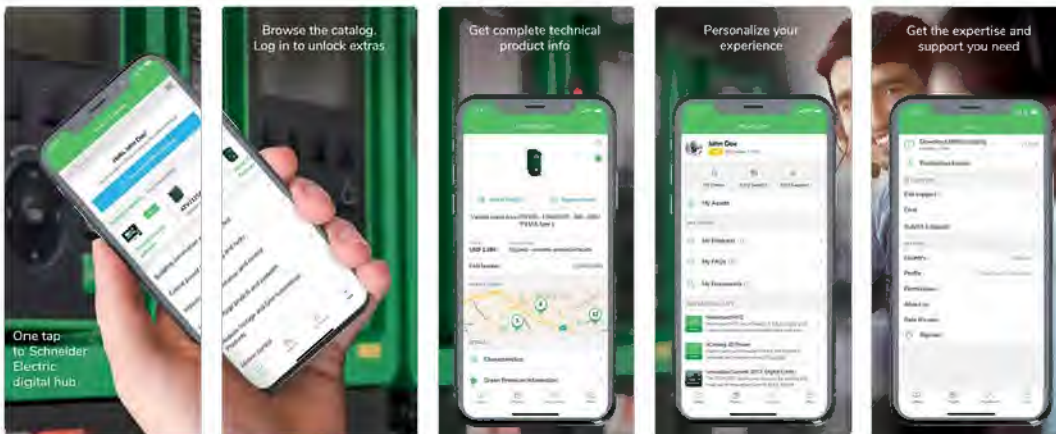

Download on the **App Store** | Get it on **Google play**

Download mySchneider for iOS > | Download mySchneider for Android >



Scan or click on QR code



Environmental Data Program

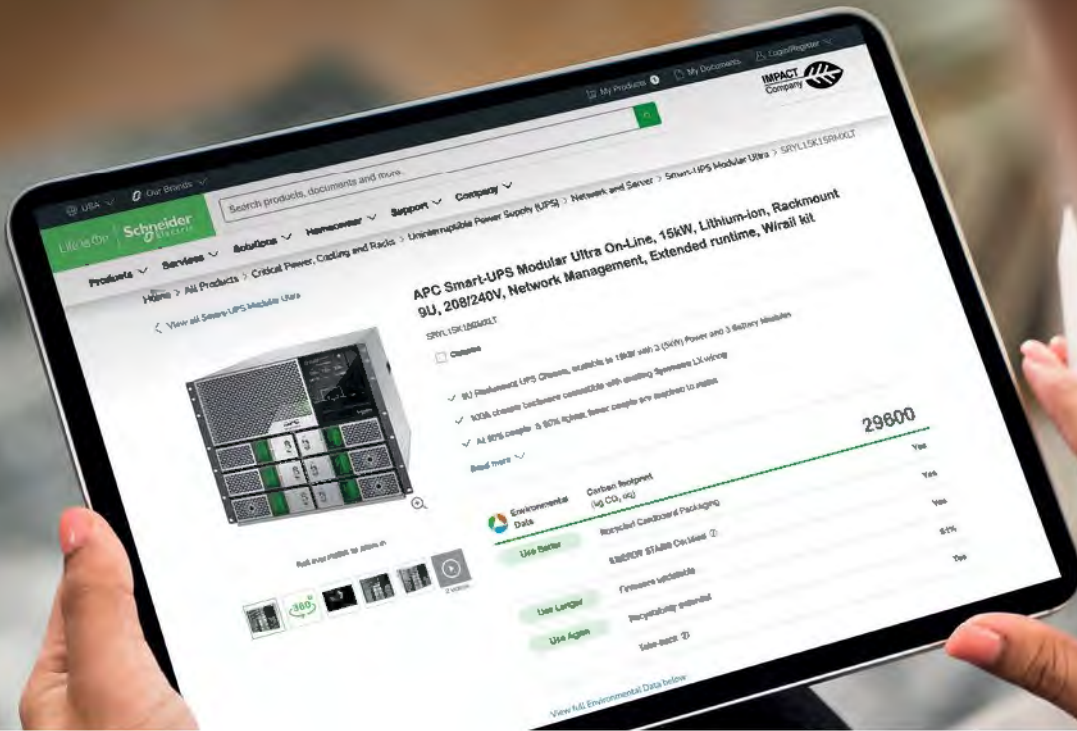

Next-level transparency for better-informed product choices

The Environmental Data Program is a framework for how we measure, categorize, and compare the environmental attributes and footprint of our products.

Using a rigorous, fact-based methodology, the program provides environmental data from across the product lifecycle.

Five data categories across the product lifecycle

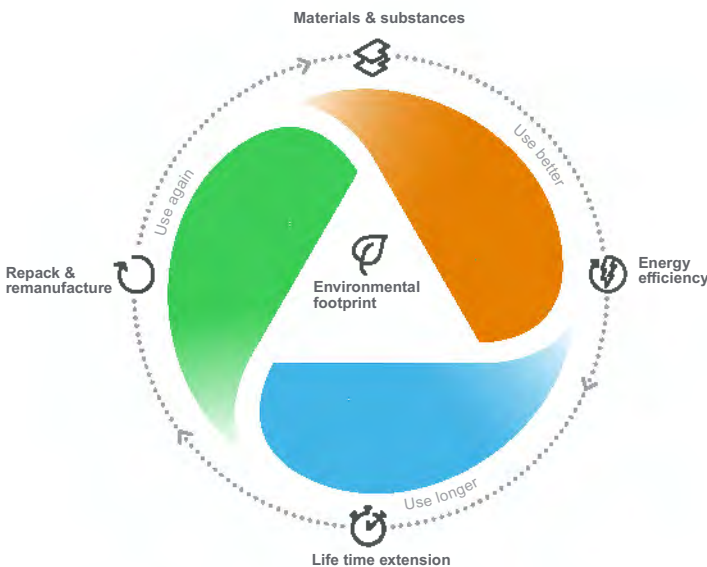

Use Better: How sustainable a product is, including environmental footprint, materials and substances, packaging, and energy efficiency.

Use Longer: How a product's life time can be effectively extended in terms of reparability and updatibility.

Use Again: How a product can be reused, from dismantling and remanufacturing to recyclability and manufacturer take back.

With this transparent, verified data, customers and partners are empowered to make conscious environmental choices and accurately evaluate and report on sustainability performance.

All our hardware offers have an associated environmental data available on se.com product pages.



Learn more about the **Environmental Data Program**

A

Switchboards and Enclosures



Okken

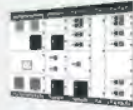

Okken Lean



BlokSeT



BlokSeT Lean



PrismaSeT G & P



PrismaSeT XS & S



PrismaSeT I



Universal enclosures and Thermal Management

B

Power circuit breakers and switches



MasterPact MTZ & Active



ComPact NS, NSX & NSXm



ComPact INS & INV



ComPact NSX DC EP



TransferPact



EasyPact MVS



EasyPact MVS New Energy



EasyPact EZC & CVS



EasyPact Solar MCCB

C

Power monitoring and power quality



PowerLogic™ range



Panel Server



HeatTag



EasyLogic Power Meters



EasyLogic PFC



EasyLogic™ APF



Vigilohm

D

Motor control



Tesy Power



Tesy Control



Tesy Protect



Tesy Active



Easy Tesys

E

Variable speed drives and soft starters



Altivar 12



Altivar ATV320



Altivar ATV340



Altivar 212



Altivar ATV600



Altivar ATV900



Altivar Soft Starter ATS480



Altistart 22



Altistart 01

F

Control and signaling, Automation relays & Power supply



Push buttons



Cam switches



Tower lights



Control and time relays



Modicon Power supply



Linergy-TR

G Electrical protection and control



H Critical Power

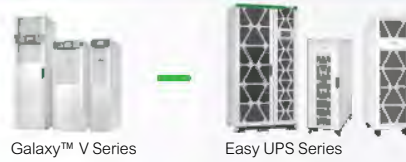

I Medium Voltage Switchgears components



J Incoming Protection



Switchboards and Enclosures

A

Okken	
General overview	A-24
General characteristics.....	A-31
Okken Lean	
General overview	A-34
General characteristics.....	A-42
Blok SeT	
General overview	A-44
General characteristics.....	A-50
Blok SeT Lean	
General overview	A-52
General characteristics.....	A-60
Prisma SeT G and P	
General overview	A-62
Technical characteristics - PrismaSeT G.....	A-68
Technical characteristics - PrismaSeT P	A-70
Prisma SeT XS & S	
General overview - PrismaSeT XS	A-75
General overview - PrismaSeT S.....	A-77
Prisma SeT I	
General overview	A-80
Technical characteristics	A-85
Universal enclosures	
General overview	A-88
Smart Panel	
General overview	A-98

A

B

C

D

E

F

G

H

I

J



Okken: intelligent switchboard solutions

With safety and reliability within reach, why settle for less?

Embodying decades of expertise, Okken™ solutions are complete and customized low-voltage (LV) power distribution, motor control, and integrated power control centres. Okken switchboards contribute to answer the need for operational safety in today's high-performance LV power applications. Versatile and durable, Okken switchboards have the comprehensive capabilities and intelligence you need to keep your business competitive.

Industry-leading features, design, and support make implementation and operation quick, easy, and reliable, so you can lower costs and realize a faster return on investment.

Okken solutions combine high level of safety and reliability with an optimized footprint, modular architecture, and smart devices.

A global player with local capabilities

Schneider Electric is present in more than 100 countries, delivering reliable products and solutions around the world. Our global reach helps us ensure high quality and local project and service capabilities, no matter your location.

Smart grid ready

Our broad expertise in electrical network management makes us a partner who knows what the smart grid means for your business, and how best to keep you at the forefront of technology.

15%

Okken solutions can provide up to 15% energy savings^[1]

200 k

More than 200,000 cubicles installed. Customers worldwide trust Okken LV switchboard solutions

[1] Based on previous data, 2015. This is not a guarantee of future performance or performance in your particular circumstances.

Electrical safety for personnel

Tested and certified by independent ASEFA and LOVAG labs

With Okken, protection is never left to chance

With high modularity and total insulation, safety is engineered into every Okken switchboard, from conception, through design, installation, and everyday operation.

Network management applications

Full type tests as per IEC 61439-1&2 confirm high level of electrical installation and operational safety. Insulation and provided screening of all live parts enhance service life and provide outstanding protection.

- Forms of internal separation up to 4b
- Embedded interlock systems to secure on-load disconnection
- Live-part protection up to IPxxD
- Fully insulated busbars
- Padlockable with three different locks
- Protection with optional doors and accessories
- Closed door racking drawers for extra operator protection in all drawer positions, particularly in case of internal short-circuit or arc event, and even during connecting and disconnecting.

Internal arc withstand and short-circuit protection

- Fully type tested in compliance with IEC TR 61641 edition 3
- Internal arc withstand up to 100 kA/0.5 s
- Arc-free zone with encapsulated active parts in the whole switchboard: incomer, horizontal busbar, withdrawable cubicle
- Active optical arc-flash detection with VAMP system
- Operator protection at three levels:
 - Horizontal and vertical busbars
 - Functional units on all three positions of withdrawable drawers
 - Outgoing cable connections
- Internal arc risk reduction thanks to our unique Polyfast™ system
- Partitioned terminals for electrical insulation between the upstream circuit breaker and the double contact clamps on the main busbar
- Rated conditional short-circuit current (Isc) up to 150 kA.



Note: In working environment, full operator safety measures should always be adopted.



Okken

Reliability and continuity of service

A

An "install-and-forget" level of dependability

The Okken design is based on a robust and type-tested architecture, standardized modules, and Schneider Electric devices. This allows functionality, continuity of supply, and installation reliability, even in very difficult environments

- All components and devices are designed by Schneider Electric and manufactured to rigorous quality standards
- Tested and validated compatibility between switchboards, functional units, and built-in devices
- Outstanding electrical and mechanical consistency and electromagnetic compatibility (EMC) of all Schneider Electric™ components.

B

C

D

E

F

G

H

I

J

Tough enough for Oil & Gas applications

- Okken switchboards are DEP Shell approved for demanding needs of Oil & Gas facilities
- Total™, Chevron™, British Petroleum™, Air Liquide™, and others place their trust in Okken intelligent switchboard solutions.

Thermal monitoring

- Permanent temperature monitoring with sensors on critical parts (Exertherm system)
- Predictive maintenance to increase the reliability of your switchboard.



Resistance to corrosive environment

- Tin, nickel, or silver busbar coating on copper conductive parts for H₂S and SO₂ atmosphere withstand
- Anticorrosion surface treatments on metallic sheets
- Okken switchboards provide a variety of protection levels (up to IP54).

Optimized for marine installations

- Okken switchboards satisfy the requirements of marine, offshore, and floating production storage and offloading applications
- They are DNV (Det Norske Veritas) and RINA (Registro Italiano Navale Group) certified for high vibration and saline environments.

Durability for seismic areas

- Okken 2.7G and 5G provide mechanical resistance and robust installation in seismic zones in compliance with the most demanding local and international standards: IBC 2006/ AC 156, IEC 68-3-3, AS1170, EAK-2000, ENDESA-1986, GOST 17516.1-90, IEEE 693-1997, EDF CRT 91 C 112 00 (on Okken 5G)
- 5G versions are specifically engineered for high-demanding nuclear and industrial applications.

Customized solutions for any application and severe environment





Oil & Gas



Offshore Platforms



Mining, Metals, Minerals



Marine



Nuclear



Water and Wastewater Treatment



Healthcare



Data Centres

- A
- B
- C
- D
- E
- F
- G
- H
- I
- J

Okken

High performance and superior efficiency

Compact, modular design - the right fit for your organization

A

Industry-leading capabilities

- Maximum busbar rating up to 7300 A
- Maximum rating of Power Control Centre (PCC), up to 6300 A
- Maximum rating of Motor Control Centre (MCC), up to 250 kW
- Smart communicating devices for connected switchboards
- Compact design for higher stacking density and optimized footprint
- Upgradeable energized equipment.

A disconnectable design for power distribution

The Polyfast system reinforces the electrical isolation of power distribution switchboard.

Power distribution

PCC including protection and power factor correction:

- Main busbar up to 7300 A
- Incomers up to 6300 A (Masterpact™ circuit breakers)
- Feeders up to 6300 A (Masterpact circuit breakers), and up to 630 A (Compact™ circuit breakers)
- Power factor correction up to 540 kVAR.

> Electrical distribution up to 7300 A.

> Incomer and feeder up to 6300 A.

> Motor control up to 250 kW.

A flexible, withdrawable design for motor control and power distribution

Compact and powerful Okken switchboards answer the needs of the most demanding motor control and power distribution applications. Combining continuity of supply and performant operational services.

Motor control

MCC including protection, starters, and drives:

- Conventional starters up to 250 kW
- Soft starters up to 315 kW
- Drives up to 160 kW.



Improved versatility and flexibility

24/7 visibility of energy use and power quality

A compact and modular design for every function

Okken is a simple and modular solution that is easy to choose, intuitive to use, cost effective, and simple to install or upgrade.

Fast, easy installation, upgrading, and maintenance

Single front or double front access thanks to back-to-back configuration, top or bottom direct power connections, rear or side power connections for easy installation. Plus, standardized dimensions and an optimized footprint save time and money during installation.

- Fixed, disconnectable, or withdrawable functional units
- Withdrawable drawer size optimization: full and half-widths, different heights from 100 to 600 mm
- Direct power plug connection to the vertical busbar (50 mm pitch)
- Drawer position indicators on front faces and drawer stop
- Withdrawable Masterpact and plug-in
- Compact circuit breaker modules
- Current transformers inside.

Upgrade Okken while under load

Easily modify and upgrade your Okken solution and add new functions as your needs change: scalability while under load, equipping of additional slots in reserved spaces, association of cubicles, fast interchangeability without special tools.

- Degree of protection up to IPxxD on busbar with automatic shutters, and on connections on busbar by plug-in clamps
- Customer connection separate from the functional unit (form up to 4b).



General overview

Okken

A iPMCC by Okken: built-in intelligence

Our digital solution for power distribution and motor control

The intelligent Power and Motor Control Centre (iPMCC) by Okken is a highly capable and advanced smart solution for application fault prevention, protection, and automatic restart in continuous and critical processes. It helps you boost productivity and optimize the energy management and efficiency of your assets while enhancing continuity of service, and reducing downtime.

B

C Energy savings up to 15%

- Integration of all your equipment to lower electrical energy consumption
- Synchronizing motors to loads with progressive starters and variable speed drives and reducing peak consumption by 50% or more¹
- Managing reactive power compensation (capacitors) and thermal withstand control to reduce costs and increase energy availability.

D

E Enhanced control and monitoring

- Better traceability and control
- Local or remote real-time information access
- Motor operating status and time monitoring (alarms and tripping)
- Parameter monitoring and management of status, measurements, diagnostics, trends, and energy consumption.

F

G Optimized motor performance

- Motor monitoring and protection in accordance with IEC/EN 60947-7-1
- Motor and protection device configuration accessible at all times
- Associated with TeSys T, iPMCC by Okken enables the detection of electrical loads faults like no-load running, shaft bearing seizure, abnormal starting or heating, pump cavitations, and pulsating torque.

H

I Smart-grid integration











- Pretested communication architectures offering leading industry protocols engineered to optimize asset energy efficiency (Ethernet/IP, Profibus[®]-DP, Modbus, TCP/IP)
- Seamless integration with energy management and control systems and process automation management systems
- Complete range of design assistance tools.



A complete range to match your toughest needs

For power distribution and motor control including variable speed drives, motor starters, power factor correction, and harmonic filtering

Enhanced efficiency and productivity

PCC ^[1]		230 Very high-power incomers and feeders up to 6300 A	PCC/MCC		115/70-2 Mixed incomers and feeders
		115 High-power incomers and feeders up to 4000 A		MCC and PCC	
		Single Masterpact MTZ-NW Single incomer or feeder (width 650 mm)			70-2 Polyfast plug-in feeders Disconnectable mounting plate
		Single Masterpact MTZ-NT-NS Single incomer or feeder (width 450 mm)	MCC ^[2]		
		70-F Fixed feeders		PFC ^[4]	
		185 Fixed feeders			

[1] PCC = Power Control Centre
 [2] MCC = Motor Control Centre
 [3] VSD = Variable Speed Drive
 [4] PFC = Power Factor Correction and harmonic filtering



Okken

Okken intelligent switchboard specifications

A

General data

Applications	Power distribution, motor control
MCC (Motor Control Centre)	Up to 250 kW
VSD (Variable Speed Drive)	Up to 160 kW
PCC (Power Control Centre)	Incomer & feeder up to 6300 A
PFC (Power Factor Correction)	Up to 690 kVAR
Standards	IEC 61439-1 & 2, IEC TR 61641, IEC 60529
Certifications	EAC (Gost), CCC, AS

B

C

D

E

Electrical data

Voltage	Up to 690 V AC (50/60 Hz)	
Main busbar rating	Up to 7300 A	
Distribution busbar rating	Up to 2100 A	
Rated short-time current (Icw)	Horizontal main busbar	Up to 150 kA rms - 1 s (peak current Ipk up to 330 kA)
	Vertical distribution busbar	Up to 100 kA rms - 1 s (peak current Ipk up to 220 kA)
Conditional short-circuit current (Isc)	Up to 150 kA	
Internal arc withstand current	100 kA – 0.5 s (IEC TR 61641 edition 3)	
Earthing system	TT-IT-TNS-TNC	

F

Communication

Protocols	Ethernet/IP, Modbus, TCP/IP, Profibus DP
-----------	--

G

H

Mechanical data

Form	2b/3b/4a/4b
Withdrawability	FFF/WFD/WFW/WWW
Seismic withstand	IBC 2006/AC 156 (site class B-C-D, floor level only), IEC68-3-3 (equivalent to Richter scale up to level 9), AS1170, EAK-2000, ENDESA-1986, GOST 17516.1-90 (civil market, all seismic intensity, up to installation level 2), IEEE 693-1997, EDF CRT 91 C 112 00 (Okken 5G only for nuclear applications)
Installation	Indoor environment type 2
Degree of protection	IP20, IP31, IP41, IP54
Operating temperature	-5°C to 35°C/50°C

I

J



Learn more about Okken range here



Scan or click on QR code

Offer

If you need more details about product references and availability, please check your local Schneider Electric contact <https://www.se.com/ww/en/work/support/country-selector/contact-us.jsp>

- A
- B
- C
- D
- E
- F
- G
- H
- I
- J

A

B

C

D

E

F

G

H

I

J



Innovative & Sustainable LV Switchboard

Okken LV Switchboards

More than 200 000 cubicles installed

Trusted by customers worldwide



Innovative Architecture in Low-voltage switchboard

- Main busbar at the rear middle low position, can provide max. flexibility for customer connection
- Single run of main busbar up to 6600 A thanks to unique architecture
- Flexible shipping unit single or multi columns

Innovative design of Busbar support and fishplate connection

Provide customer easier connection/access from the front side, minimize the labor cost from installation/maintenance time saving.

- HBB ends inside cubicle and two cubicle connection by fishplates
- Fishplate for Easy connection/access from the front side

Enhanced safety and reliability within your reach

Embodying decades of expertise, Okken Lean solutions are engineered to be complete and personalized low voltage switchboards for power distribution. Okken Lean switchboards answer the need for superior operational safety in today's high performance LV power applications.

Versatile and durable, Okken Lean switchboards have the comprehensive capabilities and intelligence you need to keep your business competitive.

Greater reliability, flexibility, and intelligence

Okken Lean solutions combine industry-leading features and designs with Schneider Electric™ support to make implementation and operation quicker and more reliable so that you can lower costs and realize a faster return on your investment. A fully functional switchboard with built-in intelligence for energy efficiency, Okken Lean is a simple and modular solution. It is easy to choose, intuitive to use, cost effective and simple to install and upgrade.

Decarbonization

Schneider Electric™ is helping our customers and partners to decarbonize is at the core of Energy Management strategy. Okken Lean provides the fastest path to Net Zero and we need more experts who understand the complexities and best practices of decarbonization to help our customers reach their sustainability ambitions faster.



Decarbonization

Up to **30%** CO₂ reduction
Material saving & power loss reduction



Material saving & Power loss reduction

Okken Lean reduce carbon and frame footprints, help you to meet the sustainability goals. The product is also simplified and streamline power distribution system, making you easier to install, commission, and maintain. Additionally, the real-time thermal monitoring solution, advanced wireless connection, and predictive maintenance features ensure the reliable and efficient operation of power distribution systems, minimizing energy waste and reducing emissions.

Investing in sustainable Okken Lean solution can also help future-proof operations by ensuring that power distribution systems can adapt to changes in energy efficiency regulations, energy costs, and other factors that may affect operations.

Okken Lean is promising solutions for the low-carbon future of LV power distribution. As more companies prioritize sustainability, these products can help to a more sustainable and environmentally responsible future. By adopting lowcarbon power distribution solutions, these industries can reduce their carbon footprint, improve their operational efficiency, and enhance the reputation as environmentally responsible companies.



Okken Lean

A

Compact design

Horizontal busbar system

Okken Lean is redesigned the architecture with innovation. The horizontal busbar system is arranged in the rear middle low position of the switchboard. This compact design brings the benefits for framework and total footprint of a sets of switchboards.

No additional holes are required for connection, make manufacturing and assembly simplify.

The innovation main busbar system reserved the maximum space between the operators and the busbar for easy installation and maintenance.

Incomers Air Circuit Breakers up to 6300 A

High design quality provides high performance, the rated current of ACB provide up to 6300 A performance.

Vertical busbar system

Optimized Vertical busbar system & link bar system, no need additional space for VBB arrangement. Okken Lean offer more size of vertical busbar options.



Compact Design

Up to **30%** footprint reduction thanks to new busbar architecture



B

C

D

E

F

G

H

I

J

230 Lean 6300/5000 A

Front View

Side View



1150 mm

600/1000 mm

115 Lean Breaker up to 4000A

Front View

Side View



650 mm

1000 mm

70F / 115 Lean Breaker up to 3200A

Front View

Side View



650 mm

1000 mm

From preventive to predictive maintenance

Minimize downtime, increase reliability

How much does an hour of downtime cost? At a stock exchange, lost transactions total €6 million. A petrochemical plant will forfeit €100,000 in productivity. And for hospitals, the cost is human lives.



Predictive Maintenance

24/7

Minimize downtime through thermal risk detection via real time monitoring

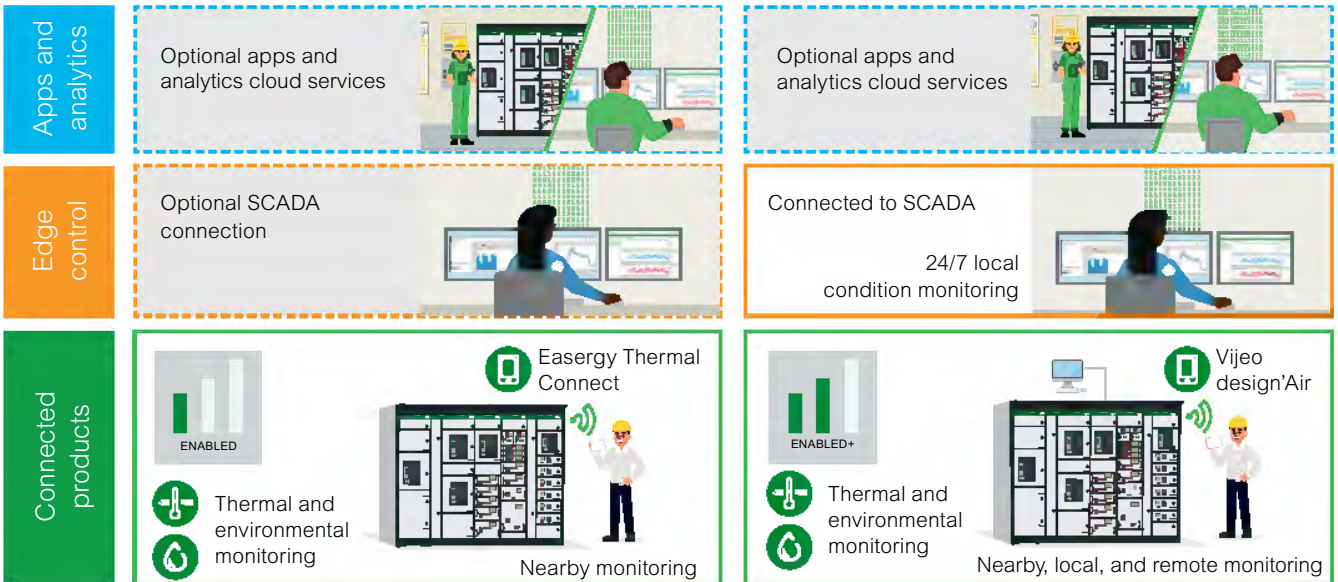

A

Wireless Okken Lean thermal monitoring solution

B

C

D

E

F

G

H

I

J

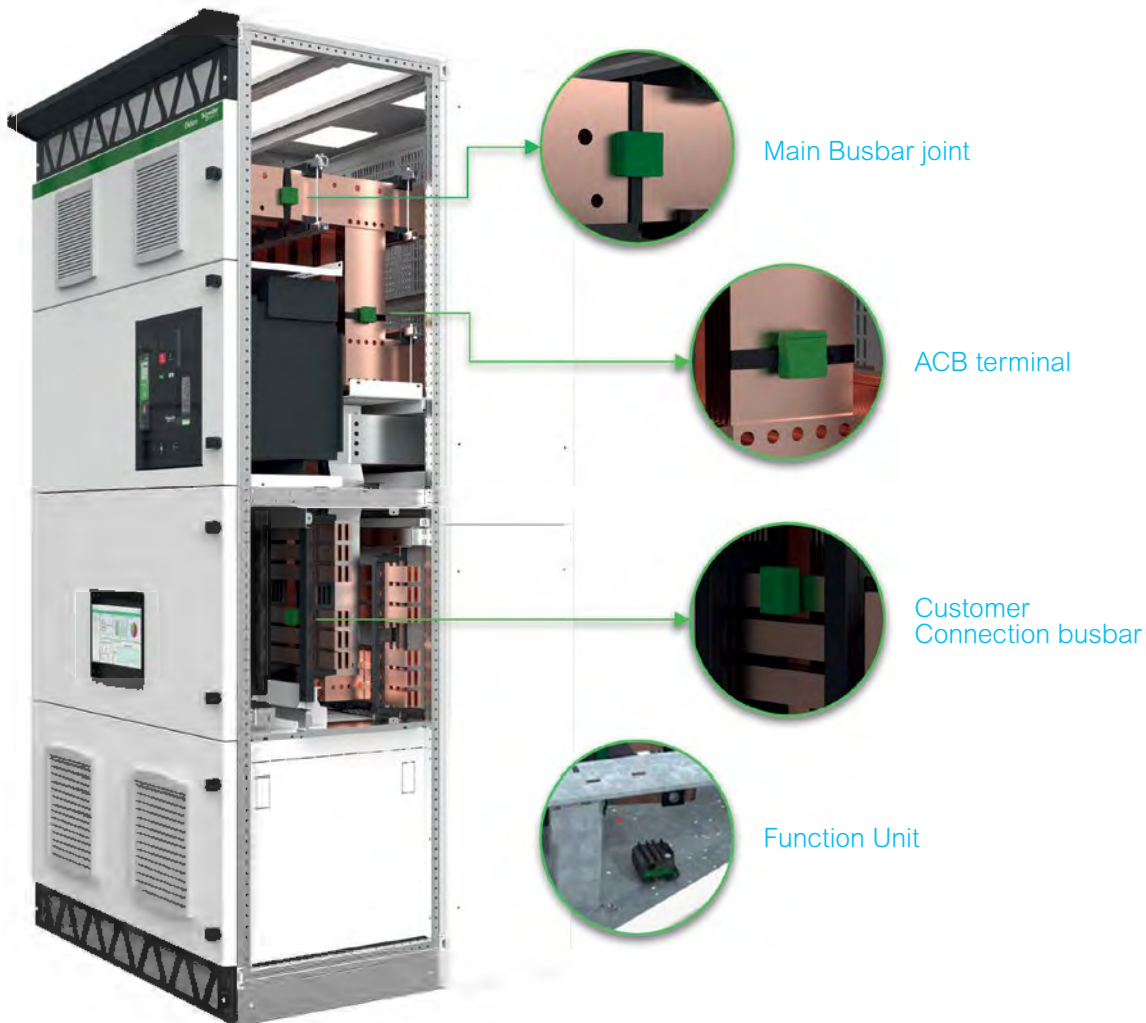

Okken Lean thermal monitoring minimizes downtime and increase safety while reducing insurance premiums related to fire risks. To keep critical equipment up and running is a priority in Data centers and Semiconductors worldwide.

The objectives are three-fold:

- Maintain operational uptime and business continuity
- Reduce operational expenses and total cost of ownership
- Protect building occupants and electrical distribution equipment

The Okken Lean Thermal Monitoring design combines a robust and proven architecture, standardized modules, and Schneider Electric devices.

Permanently installed sensors on busbar connections, cable Environmental sensor compartments, and breaker contacts provide continuous monitoring perform predictive maintenance. While IR inspections may miss critical conditions that happen between scheduled scans.

Okken Lean Thermal Monitoring not only detects potential hazards but immediately sends alerts to operations and maintenance teams, allowing them to respond before any unsafe or damaging conditions occur.



Easergy TH110
Wireless Thermal sensor

- Temperature



Easergy CL110
Wireless Environmental sensor

- Temperature
- Humidity

- A
- B
- C
- D
- E
- F
- G
- H
- I
- J

Okken Lean

A

The future of electrical solutions incorporating the **Sustainable, digital proficiency, innovative compact design**, and with **predictive maintenance** products and systems from **Schneider Electric™**.

B

Innovative horizontal busbar architecture

- Main busbar at the rear middle low position
- Provide maximum flexibility for customer connection
- Easy manufacturing, and easy installation
- Access from the front side possible.



IEC 61439-1/2
IEC TR 61641 edition 3

C

D

Fishplate

- Innovation design of fishplate connection
- Easy connection/access from the front side.

E

VBB

- VBB in the same column as Functional Unit saving the footprint.

F

G

Integrated horizontal busbar support

- l_{cw} up to 100 kA/1 s
- Simplified installation thus reducing labor time.

H

High performance

- Single run of main busbar up to 6600 A thanks to the unique architecture.

I

J

Flexible transportation

- Single or multi columns are available for shipping.



Safety

- Ingress protection up to IP54
- Forms of internal separation up to 4b
- Operator protection at horizontal & vertical busbars.

Internal arc containment 100 kA/0.5 s

- High internal arc withstand performance
- Certified on the 7 criteria as per standard requirement (IEC TR 61641 edition 3)
- Arc Flash Monitoring with VAMP.

Wireless LV thermal monitoring

- Predictive maintenance to increase the reliability of switchboard
- Nearby or remote monitoring
- 24/7 access.

Full compliance with IEC standards

- Type test campaign carried out according to IEC 61439-1/2
- Certificated by ASTA, tested by recognized laboratories.

Designed for difficult environment

- Severe earthquake conditions 2.7G, Zone 4 (Richter scale level 9)

Flexibility

- Cable connections from rear side, to optimize the switchboard length footprint
- Cable connections from front side, to limit rear area at backside of switchboard
- Cable connections from top or bottom, according to application needs.

An 'install-and-forget' level of dependability

- All components and devices are designed by Schneider Electric and manufactured to rigorous quality standards
- Tested and validated compatibility between switchboards, functional units, and built-in devices
- Outstanding electrical and mechanical consistency and electromagnetic compatibility (EMC) of all Schneider Electric components



A

B

C

D

E

F

G

H

I

J

A

Technical specifications

B

General data

Applications	Power distribution
PCC (Power Control Centre)	Incomer & feeder up to 6300 A
Standards	IEC 61439-1 & 2, IEC TR 61641, IEC 60529, IEC60947-1&2
Certification	ASTA

C

Electrical data

Voltage	Up to 480 Vac (50/60 Hz)	
Main busbar rating	Up to 6600 A	
Distribution busbar rating	Up to 2100 A	
Rated short-time current (I _{cw})	Horizontal main busbar	Up to 100 kA rms - 1s (peak current I _{pk} up to 220 kA)
	Vertical distribution busbar	Up to 100 kA rms - 1s (peak current I _{pk} up to 220 kA)
Conditional short-circuit current (I _{sc})	Up to 100 kA	
Internal arc withstand current	100 kA – 0.5 s (IEC TR 61641 edition 3)	
Earthing system	TT-IT-TNS-TNC	

D

E

Communication

Protocols	Ethernet/IP, ModBus TCP/IP, Profibus DP
-----------	---

F

Mechanical data

Form	2b/3b/4a/4b
Seismic withstand	Up to 2.7G
Installation	Indoor environment type 2
Degree of protection	IP20, IP31, IP41, IP54
Operating temperature	- 5 °C to 50 °C

G

H

I

J



Okken
Low voltage switchboards for power distribution
motor control up to 7300 A
metal-enclosed
High dependability low voltage switchboards for power distribution

Learn more about
Okken Lean
range here



Scan or
click on
QR code

Offer

If you need more details about product references and availability, please check your local Schneider Electric contact
<https://www.se.com/ww/en/work/support/country-selector/contact-us.jsp>

- A
- B
- C
- D
- E
- F
- G
- H
- I
- J

A

B

C

D

E

F

G

H

I

J



BlokSeT, the switchboard solution

Enhanced safety and reliability within your reach

Embodying decades of expertise, BlokSeT™ solutions are engineered to be complete and personalized low-voltage (LV) switchboards for power distribution and motor control.

BlokSeT switchboards answer the need for operational safety in today's high performance LV power applications. Versatile and durable, BlokSeT switchboards have the comprehensive capabilities and intelligence you need to keep your business competitive.

Greater reliability, flexibility, and intelligence

BlokSeT solutions combine industry-leading features and designs with Schneider Electric™ support to make implementation and operation quick and reliable so that you can lower costs and realize a faster return on your investment. A fully functional switchboard with built-in intelligence for energy efficiency, BlokSeT is a simple and modular solution. It is easy to choose, intuitive to use, cost effective, and simple to install and upgrade.

Benefits at a glance

- High quality design for safety and performance
- High continuity of supply, even in severe environments
- Smart solutions for energy savings and optimized operation
- Pre-engineered modular architecture for easy implementation
- Quick return on investment
- Localized support and services for ease of ownership.

1 M

More than 1 million cubicles installed. BlokSeT LV switchboards are trusted by customers worldwide



SEE THE VIDEO



Electrical safety for personnel

Tested and certified by independent ASEFA, ASTA, DEKRA recognized labs

Type-tested for high electrical installation and operational safety

With IEC 61439-1&2 and full type-testing by independent ASEFA, ASTA, DEKRA certified laboratories, you can have the peace of mind that safety is engineered into every BlokSeT switchboard.

With BlokSeT, protection is never left to chance

From conception through design, installation, and everyday operation, you can count on our commitment to maximize safety

Withdrawable drawers have three interlocked positions - connected, test, and disconnected, plus drawer stop - to improve operator safety when connecting and testing.

Smart engineering and user-friendly operation

- Built-in intelligence for energy efficiency and continuity of service
- Smart-grid ready for enhanced control and monitoring
- Fully interoperable switchboards, functional units, and devices
- Compact footprint allows more equipment and functions
- Withdrawable functional units for high availability and continuous processes
- Fixed functional units for economical applications.



Note: In working environment, full operator safety measures should always be adopted.

Improved safety measures

- Forms of internal separation up to 4b
- Embedded interlock systems to secure on-load disconnection
- Live-part protection up to IP xxB
- Fully insulated bus bars (optional)
- Padlockable with three different locks
- Protection with optional doors and accessories.

Internal arc withstand

- Fully type-tested in compliance with IEC 61641 (internal arc) to increase safety for personnel and equipment
- Internal arc containment up to 100 kA/0.5 s
- Operator protection at three levels:
 - Horizontal and vertical busbars
 - Functional units, including withdrawable drawers
 - Outgoing cable connections.

BlokSeT

A

Superior reliability and high performance

B

Outstanding safety and personalized solutions for diverse applications

Trusted worldwide for diverse industrial and infrastructural applications, BlokSeT solutions are personalized to fully satisfy different performance and harsh environmental requirements.

C

Durability in difficult environments

- Anti-corrosion: surface treatments on metallic sheets against corrosion and salt-spray
- Tin or nickel busbar coating on copper conductive parts for H2S and SO2 atmosphere withstand
- 2G version for seismic or high vibration environment.

D

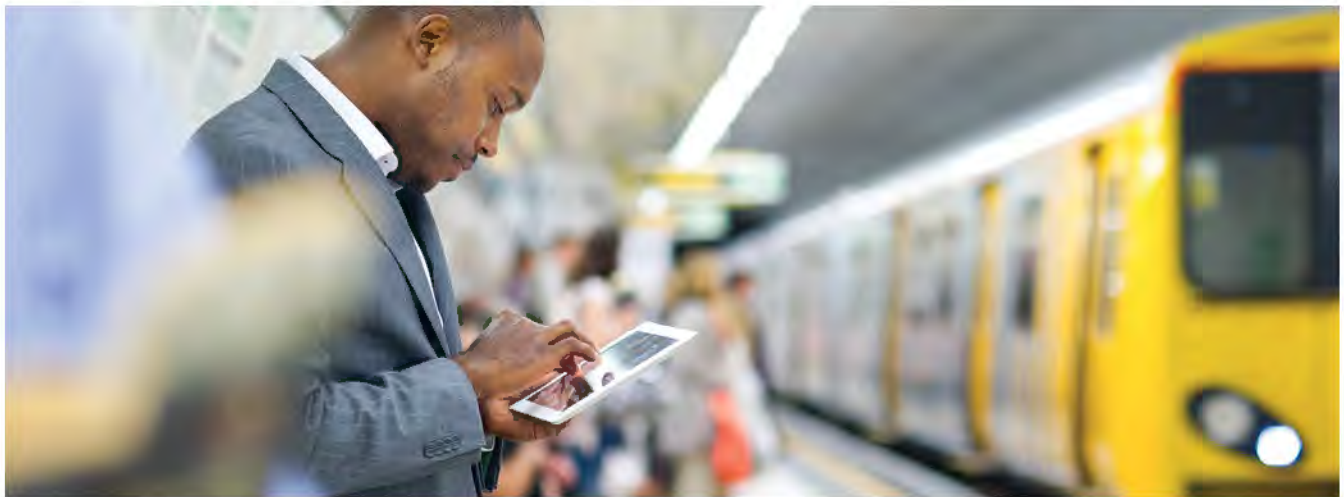

Subway and railway systems

E

F

G



Mining, metals and minerals industry

H

I

J

Schneider Electric inside: quality and compatibility

A robust architecture, type-tested, standardized modules devices work together to improve functionality, safety, continuity of supply and installation reliability even in the most difficult conditions.

- All components and accessories are designed by Schneider Electric and manufactured to rigorous quality standards
- Compatibility between switchboards, functional units, and built-in devices is tested and validated
- Schneider Electric components have outstanding electrical and mechanical consistency and electromagnetic compatibility (EMC).



Mining, metals, minerals industry



Petrochemicals



Airport



Data centers



Healthcare facilities

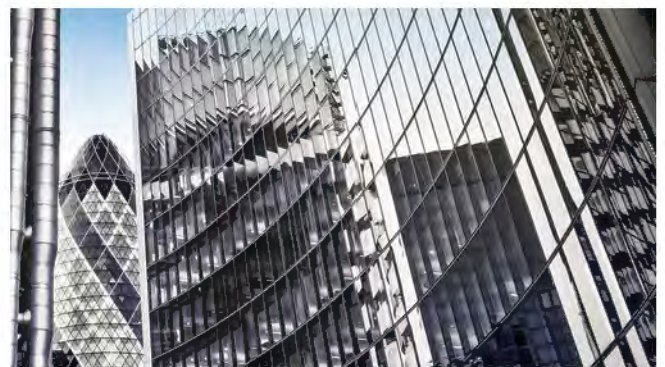

Commercial buildings

A

B

C

D

E

F

G

H

I

J

General overview

BlokSeT

A

High performance and superior efficiency

Compact, modular design - the right fit for your organization

B

Industry-leading capabilities

- Maximum busbar rating up to 7000 A
- Maximum rating of Power Control Center (PCC) up to 6300 A
- Maximum rating of Motor Control Center (MCC) up to 315 kW
- Smart communicating devices for connected switchboards
- Compact design for higher stacking density and optimized footprint
- Upgradeable energized equipment.

C

A disconnectable design for power distribution

The high-security power distribution switchboard offers maximum reinforced electrical isolation.

D

E

Power distribution

Power Control Center (PCC) including protection and power factor correction:

- Incomers up to 6300 A (MastePact™ circuit breakers)
- Feeders up to 6300 A (MasterPact™ circuit breakers) and 630 A (ComPacT™ circuit breakers)
- Power factor correction up to 646 kVAR.

F

G

H

7000 A

Electrical distribution up to 7000 A

6300 A

Incomer and feeder up to 6300 A

315 kW

Motor control up to 315 kW

I

J

A flexible, withdrawable design for motor control and power distribution

Compact and powerful switchboards answer the needs of the very demanding motor control and power distribution applications. Combining continuity of supply and reliable operational services.

Motor control

Motor Control Center (MCC) including protection, starters, and drives:

- Conventional starters up to 250 kW
- Soft starters up to 250 kW
- Drives up to 315 kW.



iPMCC by BlokSeT

Smart panel - built-in intelligence for efficient control and monitoring

Greater efficiency and enhanced productivity

iPMCC (intelligent Power and Motor Control Center) is a highly capable and advanced smart solution for fault prevention, protection, and automatic restart. It helps improve energy efficiency and reduce down time for continuous and critical processes.

Optimize motor performance

Motor monitoring and protection with failure activities in accordance with IEC/EN 60947-7-1

- Motor and protection device configuration accessible at all times
- Associated with TeSys T, iPMCC by BlokSeT enables the detection of faults like no-load running, shaft bearing seizure, abnormal starting or heating, pump cavitations, and pulsating torque.

Enhance control and monitoring

Easy access to real-time information

- Better traceability and control
- Local or remote real-time information access
- Motor operating status and time monitoring (alarms and tripping)
- Parameter monitoring and management of status, measurements, diagnostics, trends, and energy consumption.

Boost smart-grid integration

Pretested communication architectures offering leading industry protocols engineered to optimize asset energy efficiency (Ethernet TCP/IP, Ethernet/IP, Profibus®-DP, DeviceNet™, Modbus, CANopen®, etc.)

- Seamless integration with energy management and control systems, and process automation management systems
- Complete range of design assistance tools.

A

B

C

D

E

F

G

H

I

J

BlokSeT

A

A complete range for diverse applications

For power distribution and motor control including variable speed drives, motor starters, power factor correction, and harmonic filtering

B

C

D

E

F

G

H

I

J

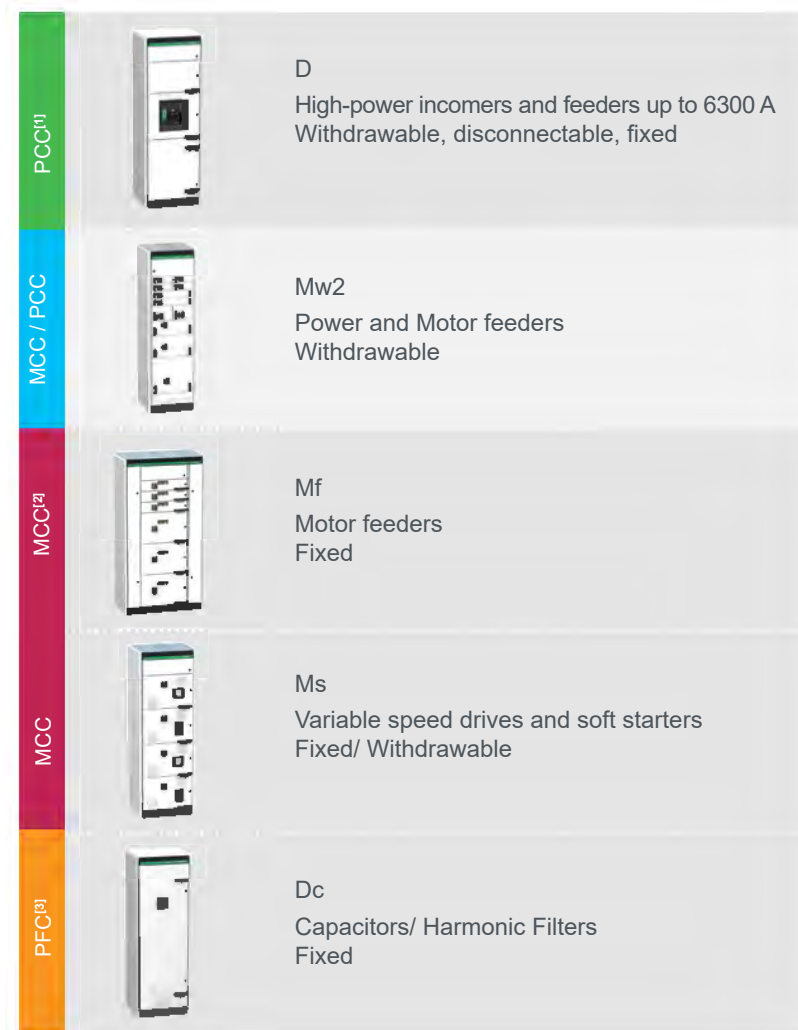

[1] PCC = Power Control Centre

[2] MCC = Motor Control Centre

[3] PFC = Power Factor Correction and harmonic filtering

BlokSeT switchboard specifications

General data	
Standards	IEC 61439-1/-2, IEC 61921, IEC TR 61641, IEC 60529, IEC 60068-2-11, IEC 60721-3-3 & IEC 61000-x-x
Certificate	Certified by recognized certification bodies ASEFA, ASTA, Dekra, and tested by independent laboratories
Electrical data	
Rated insulation voltage Ui	1000 V 3~
Rated operating voltage Ue	690 V 3~
Rated impulse withstand voltage Uimp	Up to 12 kV
Overtoltage category	Up to IV
Degree of pollution	3
Rated frequency	50/60 Hz
Main Busbar:	
Rated current Ie	Up to 7000 A
Rated peak withstand current Ipk	Up to 220 kA
Rated short-time withstand current Icw	Up to 100 kA rms - 1 s ^[1]
Distribution busbar:	
Rated current Ie	Up to 3200 A
Rated peak withstand current Ipk	Up to 220 kA
Rated short-time withstand current Icw	Up to 100 kA rms - 1 s ^[2]
Arc fault containment:	
Prospective short-circuit current	Up to 100 kA
Duration	0.5 s
Criteria (IEC TR 61641)	1 to 7
Earthing system	TT-IT-TNS-TNC
Mechanical data	
Form of separation	Up to Form 4b
Withdrawability	FFF/WWW
Seismic	UBC 97, IBC 2006 / AC 156 (site class B-C-D, floor level only), IEC 68-3-3 (equivalent to Richter scale up to level 9) / IEEE 693, GOST 17516.1-90 (civil market, all seismic intensity, up to installation level 2) 2G, zone 4
Installation	Indoor - environment type 2, EMC – Type A as per IEC 61439
Degree of protection	Up to IP54
Operating temperature	-5°C to 50°C
Vibration	IACS E10 0.7G
Corrosive atmosphere	H2S and SO2 (IEC 60721-3-3)

[1] For Main Busbar Icw = 150 kA rms - 1S and 86 kA rms - 3 s contact Schneider Electric

[2] For VBB Icw = 65 kA rms - 3 s contact Schneider Electric



Learn more about
BlokSeT
 range here



Scan or
 click on
 QR code

Offer

If you need more details about product references and availability, please check your local Schneider Electric contact
<https://www.se.com/ww/en/work/support/country-selector/contact-us.jsp>



A

B

C

D

E

F

G

H





I

J



Innovative & Sustainable LV Switchboard

Benefits at an glance

-  **Sustainable:** saving material and reducing power loss by innovative busbar architecture
-  **Reliable:** Minimize downtime through 24/7 thermal-risk detection by Predictive Maintenance
-  **Safe:** Up to form 4 separation, up to IP54 and internal arc compliance
-  **High Performance:** Full in-panel rating, and low up to 100kA/1s
-  **Compliant:** IEC 61439 -1/2 & IEC TR 61641 & IEC 60068-3-3

In addition to our overall offering and expertise, Schneider Electric is a trusted advisor. Our capabilities include designing and delivering high quality, end-to-end solutions for excellent power quality and energy efficiency, continuous availability of equipment and utilities, increased power availability of tools and utilities, and environmental compliance.



[SEE THE VIDEO](#)

Discover the future of electrical solutions with BlokSeT Lean

Innovation on BlokSeT Lean



Innovative Architecture in Low-voltage switchboard

- Main busbar at the rear middle low/high position, can provide maximum flexibility for customer connection
- Single run of main busbar up to 5000 A thanks to unique architecture
- Flexible shipping unit single or multi columns.

Innovative design of Busbar support and fishplate connection

Provide customer easier connection/access from the front side, minimize the labor cost from installation/maintenance time saving

- HBB ends inside cubicle and two cubicle connection by fishplates
- Fishplate for Easy connection/access from the front side.

Enhanced safety and reliability within your reach

Embodying decades of expertise, BlokSeT Lean solutions are engineered to be complete and personalized low voltage switchboards for power distribution. BlokSeT Lean switchboards answer the need for superior operational safety in today's high performance LV power applications.

Versatile and durable, BlokSeT Lean switchboards have the comprehensive capabilities and intelligence you need to keep your business competitive.

Greater reliability, flexibility, and intelligence

BlokSeT Lean solutions combine industry-leading features and designs with Schneider Electric™ support to make implementation and operation quicker and more reliable so that you can lower costs and realize a faster return on your investment. A fully functional switchboard with built-in intelligence for energy efficiency, BlokSeT Lean is a simple and modular solution. It is easy to choose, intuitive to use, cost effective and simple to install and upgrade.

A

Decarbonization

Schneider Electric™ is helping our customers and partners to decarbonize is at the core of Energy Management strategy. BlokSeT Lean provides the fastest path to Net Zero and we need more experts who understand the complexities and best practices of decarbonization to help our customers reach their sustainability ambitions faster.



Decarbonization

Up to **30%** CO₂ reduction
 Material saving & power loss reduction

B

C



Material saving & Power loss reduction

BlokSeT Lean reduce carbon and frame footprints, help you to meet the sustainability goals. The product is also simplified and streamline power distribution system, making you easier to install, commission, and maintain.

Additionally, the real-time thermal monitoring solution, advanced wireless connection, and predictive maintenance features ensure the reliable and efficient operation of power distribution systems, minimizing energy waste and reducing emissions.

Investing in sustainable BlokSeT Lean solution can also help future-proof operations by ensuring that power distribution systems can adapt to changes in energy efficiency regulations, energy costs, and other factors that may affect operations.

D

E

BlokSeT Lean is promising solutions for the low-carbon future of LV power distribution. As more companies prioritize sustainability, these products can help to a more sustainable and environmentally responsible future. By adopting lowcarbon power distribution solutions, these industries can reduce their carbon footprint, improve their operational efficiency, and enhance the reputation as environmentally responsible companies.

F

G

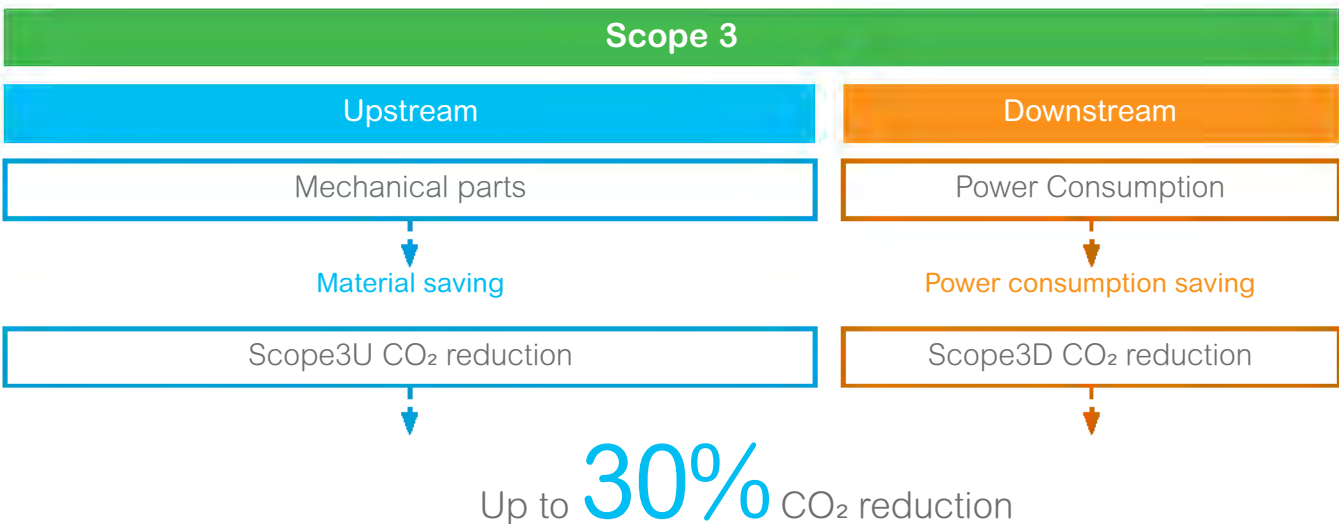

H

I

J

Compact design

Horizontal busbar system

BlokSeT Lean is redesigned the architecture with innovation. The horizontal busbar system is arranged in the rear middle low/high positions of the switchboard. This compact design brings the benefits for framework and total footprint of a sets of switchboards.

No additional holes are required for connection, make manufacturing and assembly simplify.

The innovation main busbar system reserved the maximum space between the operators and the busbar for easy installation and maintenance.

Incomers Air Circuit Breakers up to 5000 A

High design quality provides high performance, the rated current of ACB provide up to 5000 A performance.

Vertical busbar system

Optimized Vertical busbar system & link bar system, no need additional space for VBB arrangement.



Compact Design

Up to **30%** footprint reduction thanks to new busbar architecture

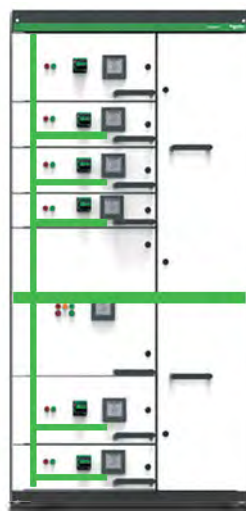
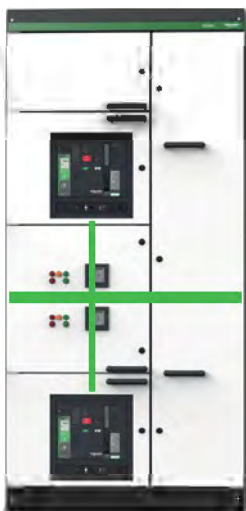
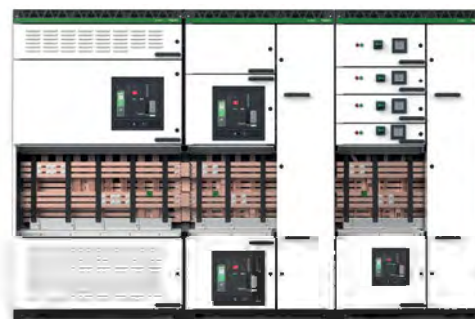

- A
- B
- C
- D
- E
- F
- G
- H
- I
- J

A

From preventive to predictive maintenance



Predictive Maintenance

Minimize downtime, increase reliability

How much does an hour of downtime cost? At a stock exchange, lost transactions total €6 million. A petrochemical plant will forfeit €100,000 in productivity. And for hospitals, the cost is human lives.

Minimize downtime through **24/7** thermal risk detection via real time monitoring

B

C

D

E

F

G

H

I

J

<p>Apps and analytics</p>	<p>Optional apps and analytics cloud services</p>	<p>Optional apps and analytics cloud services</p>
<p>Edge control</p>	<p>Optional SCADA connection</p>	<p>Connected to SCADA</p> <p>24/7 local condition monitoring</p>
<p>Connected products</p>	<p>ENABLED</p> <p>Easergy Thermal Connect</p> <p>Thermal and environmental monitoring</p> <p>Nearby monitoring</p>	<p>ENABLED+</p> <p>Vijeo design'Air</p> <p>Thermal and environmental monitoring</p> <p>Nearby, local, and remote monitoring</p>



Wireless BlokSeT Lean thermal monitoring solution

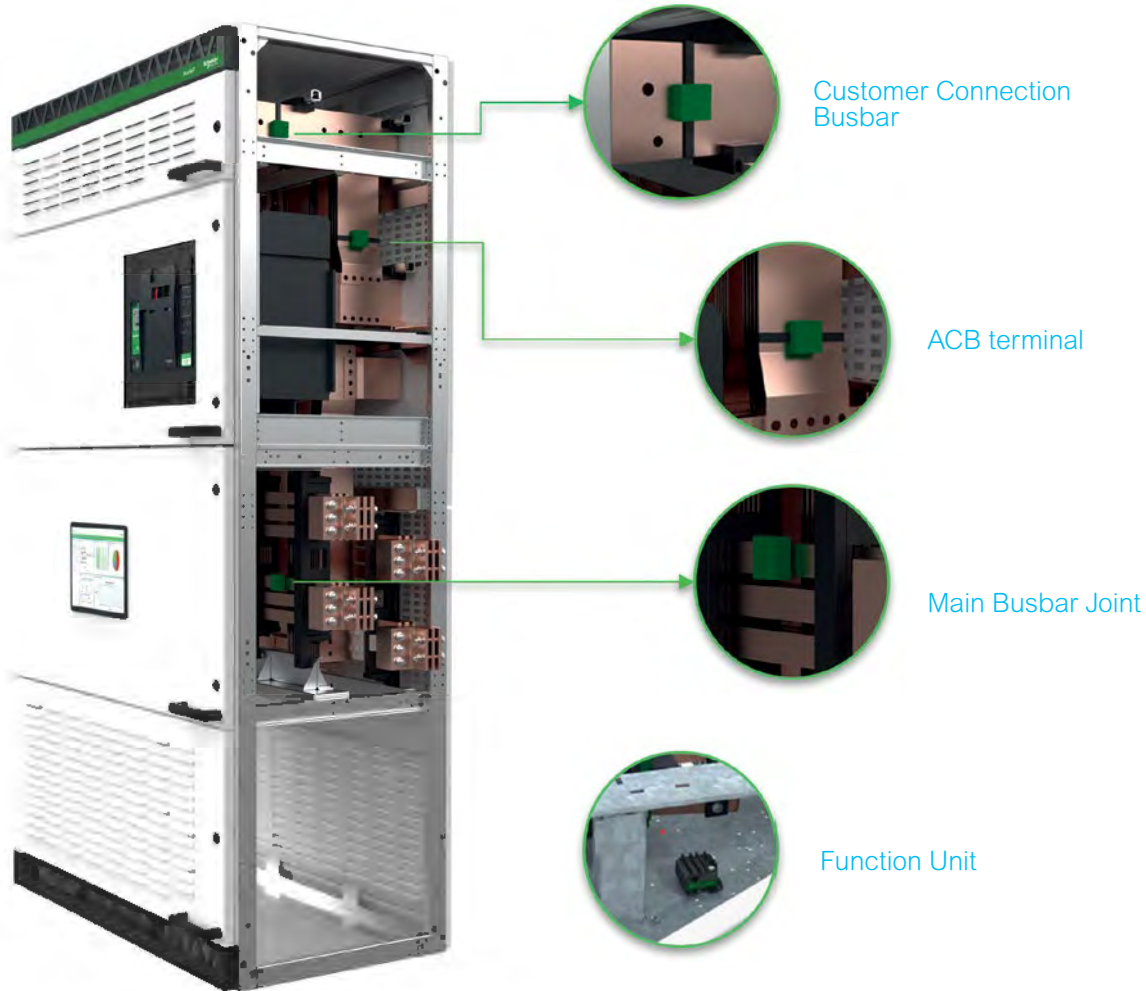

BlokSeT lean thermal monitoring minimizes downtime and increase safety while reducing insurance premiums related to fire risks. To keep critical equipment up and running is a priority in Data centers and Semiconductors worldwide.

The objectives are three-fold:

- Maintain operational uptime and business continuity
- Reduce operational expenses and total cost of ownership
- Protect building occupants and electrical distribution equipment

The BlokSeT Lean Thermal Monitoring design combines a robust and proven architecture, standardized modules, and Schneider Electric devices. Permanently installed sensors on busbar connections, cable Environmental sensor compartments, and breaker contacts provide continuous monitoring perform predictive maintenance. While IR inspections may miss critical conditions that happen between scheduled scans.

BlokSeT Lean Thermal Monitoring not only detects potential hazards but immediately sends alerts to operations and maintenance teams, allowing them to respond before any unsafe or damaging conditions occur.



Easergy TH110
Wireless Thermal sensor
• Temperature



Easergy CL110
Wireless Environmental sensor
• Temperature
• Humidity



A

The future of electrical solutions incorporating the **Sustainable, digital proficiency, innovative compact design**, and with **predictive maintenance** products and systems from **Schneider Electric™**.

B

Innovative horizontal busbar architecture

- Main busbar at the rear middle low/high position
- Provide maximum flexibility for customer connection
- Easy manufacturing, and easy installation
- Access from the front side possible
- Integrated horizontal busbar support
- Icw up to 100 kA/1 s.

C

D

E

Fishplate

- Innovation design of fishplate connection
- Easy connection/access from the front side.

F

G

Link bar

- Optimize the route of ACB connection
- Simplify installation thus reducing labor time.

H

High performance

- Single run of main busbar up to 5000 A thanks to the unique architecture
- Single or multi columns are available for shipping

I

J



IEC 61439-1/2
IEC TR 61641 edition 3

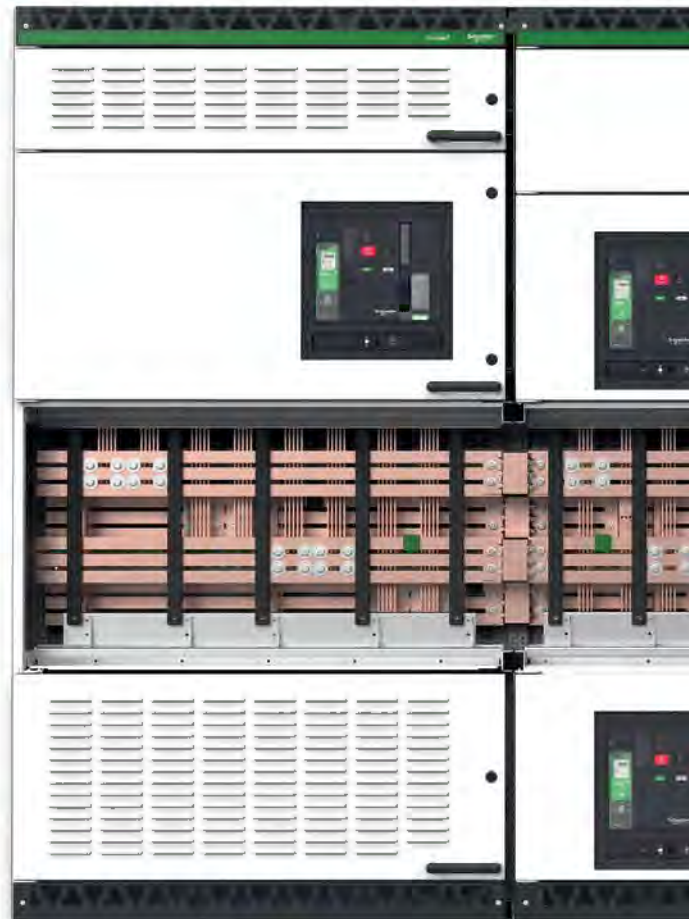

Safety

- Ingress protection up to IP 54
- Forms of internal separation up to 4b
- Operator protection at horizontal & vertical busbars

Internal arc containment 100 kA/0.5 s

- High internal arc withstand performance
- Certified on the 7 criteria as per standard requirement (IEC TR 61641 edition 3)
- Arc Flash monitoring with VAMP.

Wireless LV thermal monitoring

- Predictive maintenance
- Nearby or remote monitoring
- 24/7 access.

Full compliance with IEC standards

- Type test campaign carried out according to IEC 61439-1/2
- Certificated by ASTA, tested by recognized laboratories.

Designed for harsh environment

- H2S/SO2 chemical atmospheres
- Severe earthquake conditions 2G, Zone 4 (Richter scale level 9)

Flexibility

- Cable connections from rear side, to optimize the switchboard length footprint
- Cable connections from front side for limited area at backside of switchboard.
- Cable connections from top or bottom, according to application needs

Schneider Electric inside

- Best-in-class power distribution with connected devices
- Designed, tested, and manufactured to rigorous quality standards

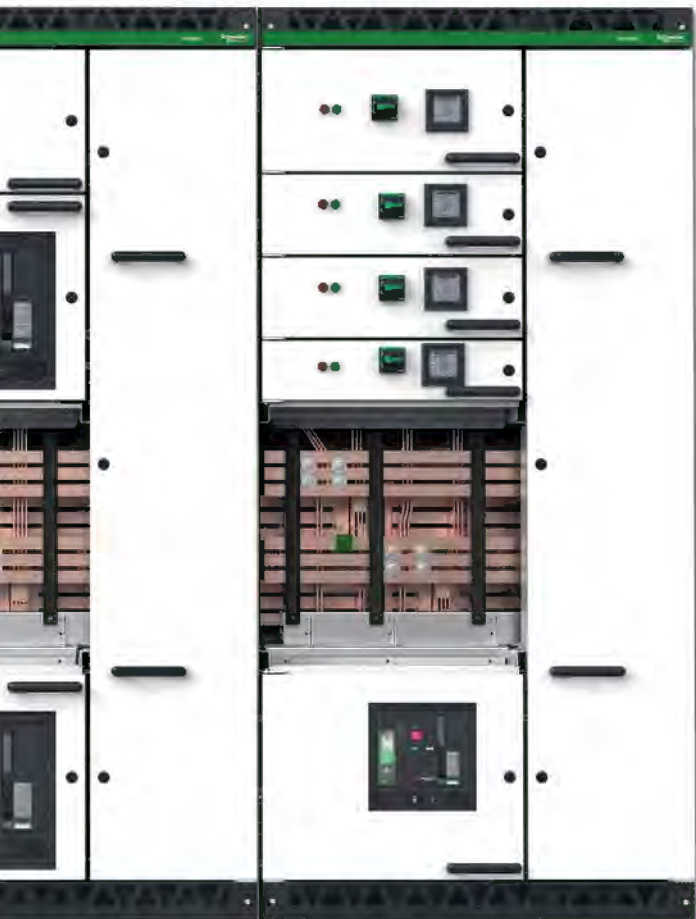

A

B

C

D

E

F

G

H

I

J

A

General data

Rating	Incomer & feeder up to 5000 A
Standards	IEC 61439-1 & 2, IEC TR 61641, IEC 60529
Certification	ASTA

B

Electrical data

Voltage	Up to 480 V AC (50/60 Hz)	
Main busbar rating	Up to 5000 A	
Distribution busbar rating	Up to 1900 A	
Rated short-time current (I _{cw})	Horizontal main busbar	Up to 100 kA rms - 1 s (peak current I _{pk} up to 220 kA)
	Vertical distribution busbar	Up to 100 kA rms - 1 s (peak current I _{pk} up to 220 kA)
Conditional short-circuit current (I _{sc})	Up to 100 kA	
Internal arc withstand current	100 kA – 0.5 s (IEC TR 61641 edition 3)	
Earthing system	TT-IT-TNS-TNC	

C

Mechanical data

Form	2b/3b/4a/4b
Seismic withstand	IBC 2006/AC 156 (site class B-C-D, floor level only), IEC68-3-3 (equivalent to Richter scale up to level 9), AS1170, EAK-2000, ENDESA-1986, GOST 17516.1-90 (civil market, all seismic intensity, up to installation level 2), IEEE 693-1997, EDF CRT 91 C 112 00 (2G)
Installation	Indoor environment type 2
Degree of protection	IP20, IP31, IP42, IP54
Operating temperature	-5°C to 50°C

D

E

F

G

H

I

J



Learn more about
BlokSeT Lean
range here



Scan or
click on
QR code

Offer

If you need more details about product references and availability, please check your local Schneider Electric contact <https://www.se.com/ww/en/work/support/country-selector/contact-us.jsp>



A



B

C

D

E

Panel building system for power distribution switchboards, up to 4000 A



PrismaSeT G

F

To respond to increasing building requirements



PrismaSeT P

G



H



I



J



Improve the continuity of service



Ensure the safety of life and property



Control deadlines and costs

PrismaSeT:

the optimised, tested and IEC compliant solution,
for low voltage electrical distribution and control switchboards.



PrismaSeT, a comprehensive range of enclosures and cubicles

- A solution based on more than **30 years of experience** in low voltage switchboards.
- Integrating Schneider Electric switchgear offerings and ensuring electrical, mechanical and communication **functions complete consistency**.
- Quality production, **certified ISO 9001** and manufactured in Montmélian (France).

A

B

C

D

E

F

G

H

I

J

PrismaSeT G and P

Develop your business efficiency

A



Switchboards that are safe...

With PrismaSeT you can be sure to build 100% Schneider Electric switchboards that are safe, optimised:

- All components (switchgear, distribution blocks, prefabricated connections, etc.) are perfectly rated and coordinated to work together.
- All switchboard configurations, even the most demanding ones, have been tested.

You can prove that your switchboard meets the current standards, at any time.

You can be sure to build a reliable electrical installation and give your customers full satisfaction in terms of dependability and safety for people and the installation.



Tested low voltage switchboard, IEC 61439-1&2 compliant.

B

C

D

E

F

G

H

I

J

-
- +**
- > Available power.
 - > Safety of people and property.
 - > Controlled costs and delivery times.
 - > Upgradeability.
-

With our functional LV systems

...optimised and upgradeable

With PrismaSeT you can build just the right switchboard for your customer, sized precisely to fit costs and needs. With this complete, prefabricated and tested system, it's easy to upgrade your installation and still maintain the original performance levels.

- The cubicles combine easily with switchboards already in service.
- Devices can be replaced or added at any time.

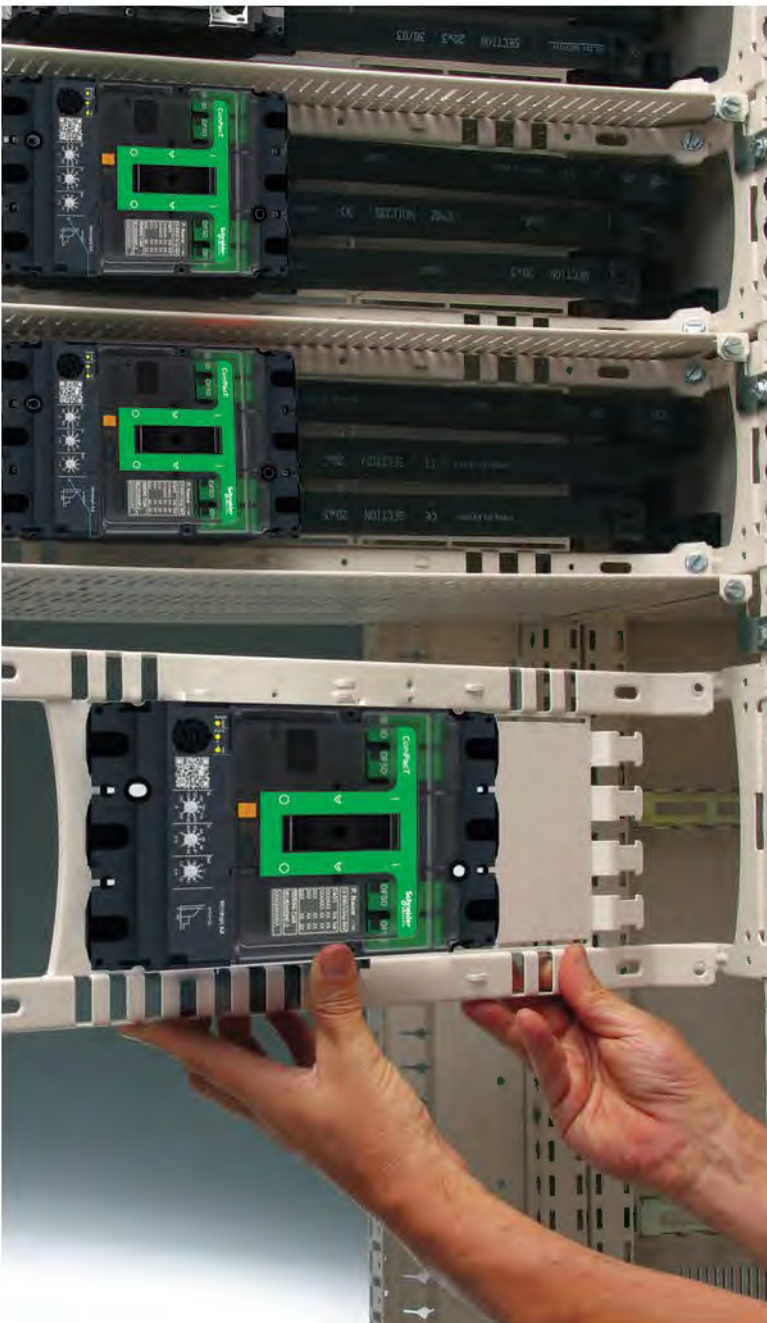

Straightforward organisation to make your job easier

The switchboard is structured by zones dedicated to switchgear, busbars, cables, etc.

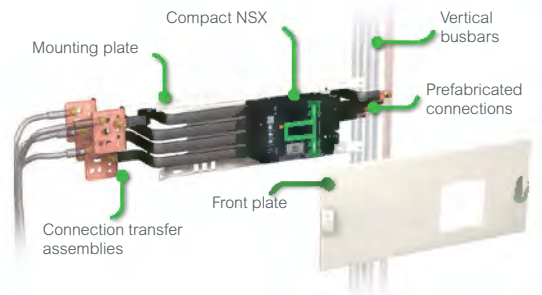

The functional units are naturally stacking in the switchboard.

Each configuration is tested for improved safety.



Temperature rise test in laboratory.

Readily available close by

The kit concept makes handling and transport easier and you get to benefit from Schneider Electric's efficient international logistics. Your distributor, selected by Schneider Electric, can give you the very best advice.



PrismaSeT G and P

A

PrismaSeT Pack 250 A enclosures

PrismaSeT G enclosures

IP30 / IP4X, IP55, up to 630 A

B

C

D

E

F

G

H

I

J



160 A

250 A

630 A

- Schools
- Small shops
- Hotels, etc.

Pack



- Small companies
- Buildings
- Offices
- Laboratories
- Healthcare centres
- Hotels
- Supermarkets
- Malls, etc.

PrismaSeT G



PrismaSeT P cubicles up to 4000 A IP30, IP31, IP55

The optimised, tested and IEC compliant solution, for low voltage electrical distribution and control switchboards.



- Hospitals
- Data centres
- Logistics centres
- Shopping centres
- Offices buildings
- Medium industrial solutions

PrismaSeT P



Energy management has never been simpler

Smart Panels connect you to energy savings in three steps.

1. Measure

Embedded and stand-alone metering & control capabilities

- Embedded and stand-alone metering
- Control capabilities

2. Connect

- Integrated communication interfaces
- Ready to connect to energy management platforms

3. Act

- Data-driven energy efficiency actions
- Real time monitoring and control
- Access to energy and site information through on-line services



Tested, Validated,
Documented Smart Panels architecture
Smart Panels have been certified via
Schneider Electric's "TVDA" quality process
Tested in performance labs by experts, in the most
common configuration
Validated full functional compatibility of devices
Documented, with user guide, predefined CAD
panel designs & wiring diagrams



PrismaSeT G

Electrical switchboards up to 630 A

A

The PrismaSeT G functional system can be used for all types of low voltage distribution switchboards up to 630 A, in commercial and industrial environments.

B

C

D

E



F



Switchboard design is very simple

1. A metal structure

The switchboard is made up of one or more enclosures, combined width-wise and/or height-wise, with a choice of doors (plain or transparent).

2. A distribution system

A complete offer of centralised or row distribution blocks, with busbars in duct or on rear of enclosure, provides current distribution over the full height of the switchboard.

3. Complete functional units

Built around each device, the functional unit includes:

- a dedicated mounting plate for device installation
- a front plate to block direct access to live parts
- prefabricated busbar connections to connect devices to the busbar
- cable-running accessories can be clipped onto the back of double-profile modular rails.

Each functional unit contributes to a function in the switchboard.

The system includes everything required for functional unit mounting, supply and connection.

The PrismaSeT G and functional unit components, in particular, have been designed and tested according to device characteristics.

This design approach ensures a high degree of reliability in system operation and optimum safety.

G

H

I

J



Assets of PrismaSeT switchboards

1. A dependable electrical installation

The total compatibility of Schneider Electric devices with the PrismaSeT enclosure is a key advantage in ensuring a high level of installation dependability.

2. An upgradeable electrical installation

Thanks to modular design, PrismaSeT switchboards can be easily modified to integrate new functional units as needed.

Maintenance operations, carried out with the switchboard de-energised, are fast and straight-forward due to easy access to devices.

3. Total safety for personnel

Work in a switchboard must be carried out by authorised persons in compliance with all applicable safety regulations.

To increase the safety of personnel, devices are installed behind protective front plates; only the operating handles are accessible. Additional internal protection (partitions, barriers) is available to protect against direct contact with live parts.

Terminal shields are mandatory for installing ComPacT NSX and INS/INV devices in PrismaSeT for even more personnel safety.

PrismaSeT G

Electrical switchboards up to 630 A

System design has been validated by type tests as per standard IEC 61439-1 & 2 and benefits from the combined experience of Schneider Electric over many years.

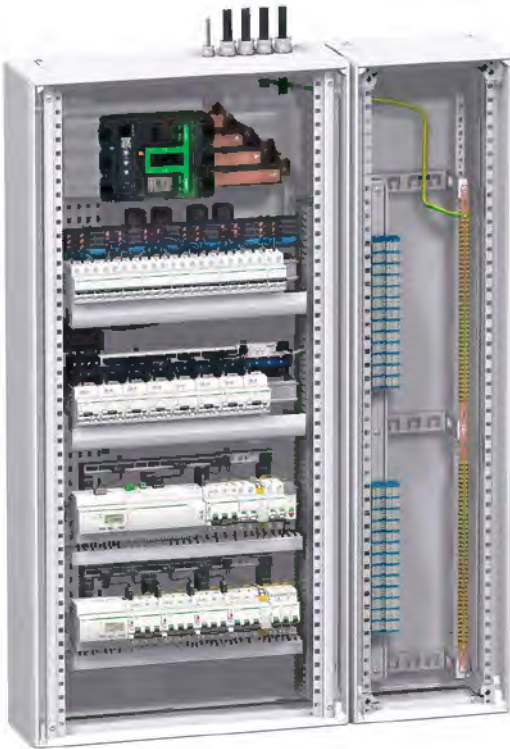

Electrical characteristics

Comply with IEC 62208 and EN 62208 standards:

- rated insulation of main busbars at rear of enclosure: 1000 V
- InA: 630 A
- rated peak withstand current Ipk: 53 kA
- short-circuit current Icc: 50 kA
- frequency: 50/60 Hz.



Mechanical characteristics

- Steel sheet metal.
- Electrophoresis treatment + hot-polymerised polyester epoxy powder, white colour RAL 9003.
- Enclosures supplied in kit form, totally dismantlable, designed to be assembled and wired horizontally on a work station.
- Can be combined side by side and one on top of another.
- Degree of protection:
 - IP30: without door
 - IP40: with door
 - IP41: with door + canopy
 - IP43: with door + gasket + canopy
 - IP55: IP55 PrismaSeT G offer, supplied in kit form.
- degree of protection against mechanical impacts:
 - IK07: without door
 - IK08: with door (transparent)
 - IK10: with plain door
 - IK10: for PrismaSeT G IP55.
- Seismic characteristics: 2.5G without accessories.
- Enclosure dimensions:
 - 3 widths:
 - W = 300: ducts
10 modules width
 - W = 600: Wall-mounted and floor-standing enclosures,
24 modules width
 - W = 850: Floor-standing enclosures
36 modules width
 - depth with door:
 - enclosures G IP30: 250 mm
 - enclosures G IP55: 260 mm
 - heights:
 - PrismaSeT G IP30: 12 heights: 330 mm to 1980 mm
 - PrismaSeT G IP55: 7 heights: 450 mm to 1750 mm.
- Inside switchboards.



Readily available close by

The kit concept makes handling and transport easier and you get to benefit from Schneider Electric's efficient international logistics.

Your distributor, hand-picked by Schneider Electric, can give you the very best advice.



Electrical switchboards built using the PrismaSeT functional system and Schneider Electric recommendations fully comply with international standard IEC 61439-1&2.

A

B

C

D

E

F

G

H

I

J

PrismaSeT P - Reliable, Easily connected





The new Prisma**SeT** P switchboard is the market forerunner with built-in cloud connectivity, allowing instant access to smart alarm system, energy usage analysis, trends, and preventative maintenance plans. Built-in cloud connectivity allows users to be notified of the round-the-clock electrical distribution as well as voltage loss if any. This maximizes efficiency and power availability, while creating the basis for future innovations. The Prisma**SeT** P switchboard also allows easy wireless integration of sensors.

Offer values

-  **Simplicity**
 - Deliver connectivity without any complexity
-  **Easy installation**
 - Simple-to-install connected solution
-  **Robustness and Design**
 - New design with new structure color, increased frame and door robustness
-  **Win more business**
 - Increase the service business opportunities while offering an affordable connected panel
-  **Protection**
 - Deliver greater peace of mind



Digital journey

-  **Peace of mind on the Cloud**
 - Electrical Fire Prevention
 - Power availability at no cost
 - Energy awareness
-  **Built-in connectivity**
 - Voltage loss alert free of charge
 - Connection to cloud in less than 5 min without any IT skill
-  **Easy-to-install 100% wireless communication solutions**
 - User friendly installation instructions
 - Independent from customer IT
-  **Easy installation and commissioning**
 - Less than 30 minutes for setting up the communication devices

PrismaSeT P - Reliable, Easily connected

New design with sustainable packaging

Enhance buildings with in-built connectivity and efficient design

The new design of PrismaSeT P increases the robustness of the panels, helps to gain efficiency on every level and provides peace of mind to the panel builders, electrical contractors and facility managers.

In addition, the new 100% green packaging decreases the quantity of waste and its disposal cost by using only cartons.

Green Packaging

- Progressive cancellation of plastic and polystyrene of packaging.
- 100% recyclable cardboards.
- Time & money saving to sort waste.
- New cross beam in cardboard for a more robust packaging.



Reinforced Frame

- Easier transportation and perception during assembly.
- Reinforcement on the lower angle levels using additional accessories.

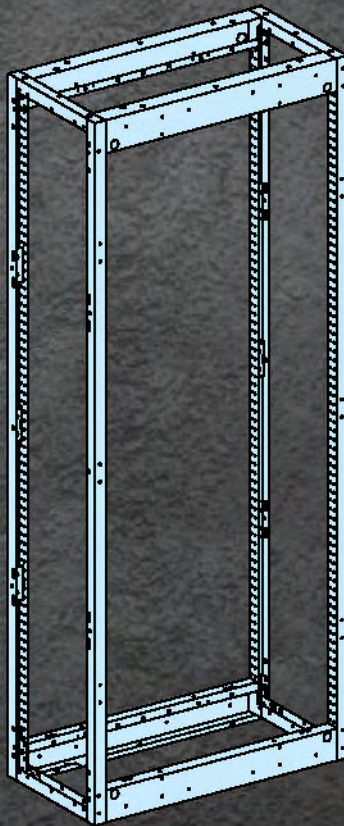

Reinforced Plain Door

- 3 hinges
- Sheet metal thickness 1.5 mm
- 20 x 20 bar reinforcement

IP 30/31 Plain Door

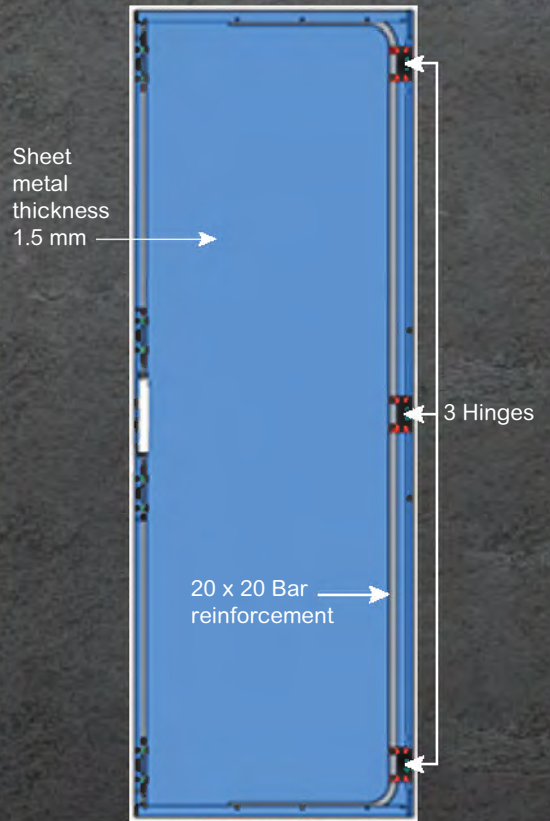

New Improved Handle

- More robust handle.
- Keyless entry door.
- Ergonomic and Aesthetically handle design.



Digital Instruction Sheets

- Cancellation of systematic printed instruction in each packaging.
- 1 printed 'Super Leaflet' with all instructions (available to order once).
- 1 systematic QR code to link to the right instruction sheets.

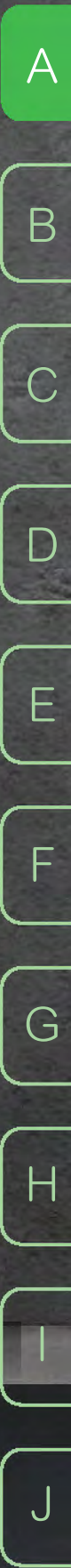

PrismaSeT P

Electrical switchboards up to 4000 A

The PrismaSeT P functional system can be used for all types of low-voltage distribution switchboards (main, subdistribution and final) up to 4000 A, in commercial and industrial environments.

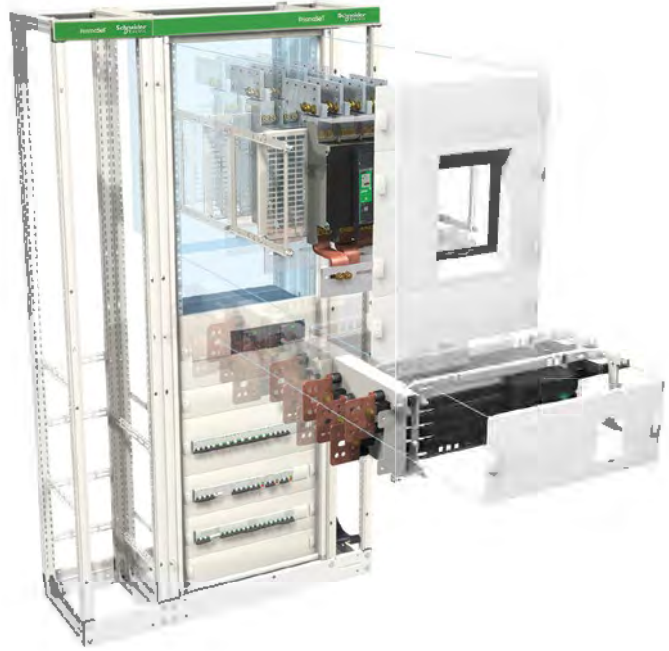

Switchboard design is very simple

1. A metal structure

The switchboard is made up of one or more frameworks combined side-by-side or back-to-back, on which a complete selection of cover panels and doors can be mounted.

2. A distribution system

Horizontal busbars or vertical busbars positioned in a lateral compartment or at the rear of the cubicle are used to distribute electricity throughout the switchboard.

3. Complete functional units

- a dedicated mounting plate for device installation
- a front plate to block direct access to live parts
- prefabricated busbar connections
- devices for on-site connections.

Each functional unit contributes to a function in the switchboard.

The functional units are modular and are arranged rationally.

The system includes everything required for functional unit mounting, supply and onsite connection.

The components of the PrismaSeT P and those of the functional units in particular have been designed and tested taking into account device characteristics.

This design approach ensures a high degree of reliability in system operation and optimum safety for personnel.



Assets of PrismaSeT P switchboards

1. A dependable electrical installation

The total compatibility of Schneider Electric devices with the PrismaSeT P is a key advantage in ensuring a high level of installation dependability.

2. An upgradeable electrical installation

Thanks to modular design, PrismaSeT P switchboards can be modified easily to integrate new functional units as needed. Maintenance operations, carried out with the switchboard de-energised, are fast and straight-forward due to easy access to devices.

3. Total safety for personnel

Work in a switchboard must be carried out by authorised persons in compliance with all applicable safety regulations.

To increase the safety of personnel, devices are installed behind protective front plates; only the operating handles are accessible. Additional internal protection (partitions, barriers) is available to create form 2, 3 or 4 separation to protect against direct contacts with live parts.

Terminal shields are mandatory for installation of ComPacT NSX and INS/INV devices in PrismaSeT P enclosures.

4. Connected solution

- Fire prevention
- Power availability
- Energy Management.

PrismaSeT P

Electrical switchboards up to 4000 A

System design has been validated by type tests as per standards IEC 61439-1 and 2 and benefits from the combined experience of Schneider Electric customers over many years.



Electrical characteristics

- Complying with standards IEC 62208 and EN 62208:
- rated insulation level of main busbars: 1000 V
- InA: 4000 A
- rated peak withstand current I_{pk}: 220 kA
- rated short-time withstand current I_{cw}: 100 kA rms / 1 second
- frequency: 50/60 Hz
- voltage U_e = 690 V under conditions.



Mechanical characteristics

- Steel sheet metal.
- Cathaphoresis treatment + hot-polymerised polyester epoxy powder, white colour RAL 9003.
- Can be dismantled.
- Can be combined side-by-side and back-to-back.
- Degree of protection:
 - IP30: with IP30 cover panels including a door or a cover frame
 - IP31: with IP30 cover panels including a door + gasket
 - IP55: with IP55 cover panels.
- Degree of protection against mechanical impacts:
 - IK07: with cover frame
 - IK08: with IP30 door
 - IK10: with IP55 door.
- Framework dimensions:
 - four widths:
 - W = 300: cable compartment
 - W = 400: cable compartment or device compartment
 - W = 650: device compartment or cable compartment
 - W = 800: device compartment with busbar compartment or cable compartment
 - two depths: 400, 600 mm
 - height: 2000 mm.
- Indoor cubicles.



See "How to assemble an electrical switchboard"
Guide DESW043EN



Electrical switchboards built using the PrismaSeT P functional system and Schneider Electric recommendations fully comply with international standards IEC 61439-1 and 2.

Learn more about PrismaSeT range here



PrismaSeT P offer



PrismaSeT G offer



Catalogue PrismaSeT P



Catalogue PrismaSeT G

Scan or click on QR code

If you need more details about product references and availability, please check your local Schneider Electric contact <https://www.se.com/ww/en/work/support/country-selector/contact-us.jsp>



PrismaSeT XS & S

A

B

C

D

E

F

G

H

I

J



PrismaSeT XS & S: New enclosures for small commercial & residential applications up to 125 A and 160 A

Schneider Electric has always prioritized accompanying our customers with their businesses and adapting efficiently to new opportunities in commercial buildings. We prioritize quality and innovation in digital energy management and electrical distribution solutions. Our customers' satisfaction and loyalty give us the privilege of being a leader in commercial business for electricians.



Facility Expert for Small Business

A connected solution that minimizes downtime, assures business continuity & reduces the risk of financial loss.



System Configurator

Simple & free tools to configure and quote for your electrical panels.

The easy choice made for your peace of mind up to 125 A

Ergonomy

PrismaSeT XS brings the comfort of cabling for Electricians & Panel Builders

- Removable chassis for all sizes and DIN rail in 24M
- Adjustable DIN rail interaxes 125, 150, 175 mm
- Large space for wiring and accessories included in 24M
- Terminal block easy disconnection due to non-aligned holes
- Removable entry plate on top and bottom of the enclosure.

Full Plastic Enclosures' Range

- From 1 to 6 Rows, available in 13, 18, and 24 modules
- Available in Surface and Flush Mounted variants
- Several types of Doors available:
 - Transparent for 24M
 - Smoked for 13 & 18M
 - Plain for 13, 18 & 24M
- Class 2 for all PrismaSeT XS enclosures

Vertical distribution on 24 modules

- Fast and simplified distribution, thanks to direct and frontal access to the head of groups and groups of devices
- Side installation for space release on the DIN rail
- High reliability of cabling thanks to screwless connections
- Push-in technology for tool-less connections
- Fast connection up to 16 mm



A

B

C

D

E

F

G

H

I

J

A

We provide you with a complete system for residential and XS building architecture

B

Main incomer Acti9 NG125

Acti9 NG125 is the DIN Rail Modular circuit breaker up to 125 A that expertly combines simplicity with reliability.

C

D

E

F

PowerTag

PowerTag Energy is a compact and easy-to-install Class 1 Wireless communication energy sensor that monitors and measures energy and power in real time. It also sends alerts in the event of an electrical anomaly so business owners can count on PowerTag Energy for operational efficiency and uptime.

G

H

I

Acti9 iC40

New Acti9 iC40 18 mm Phase Neutral modular system for final distribution provides unmatched performance when it comes to simplifying installation, speed, space-saving as well as ease of maintenance and upgradation.

J

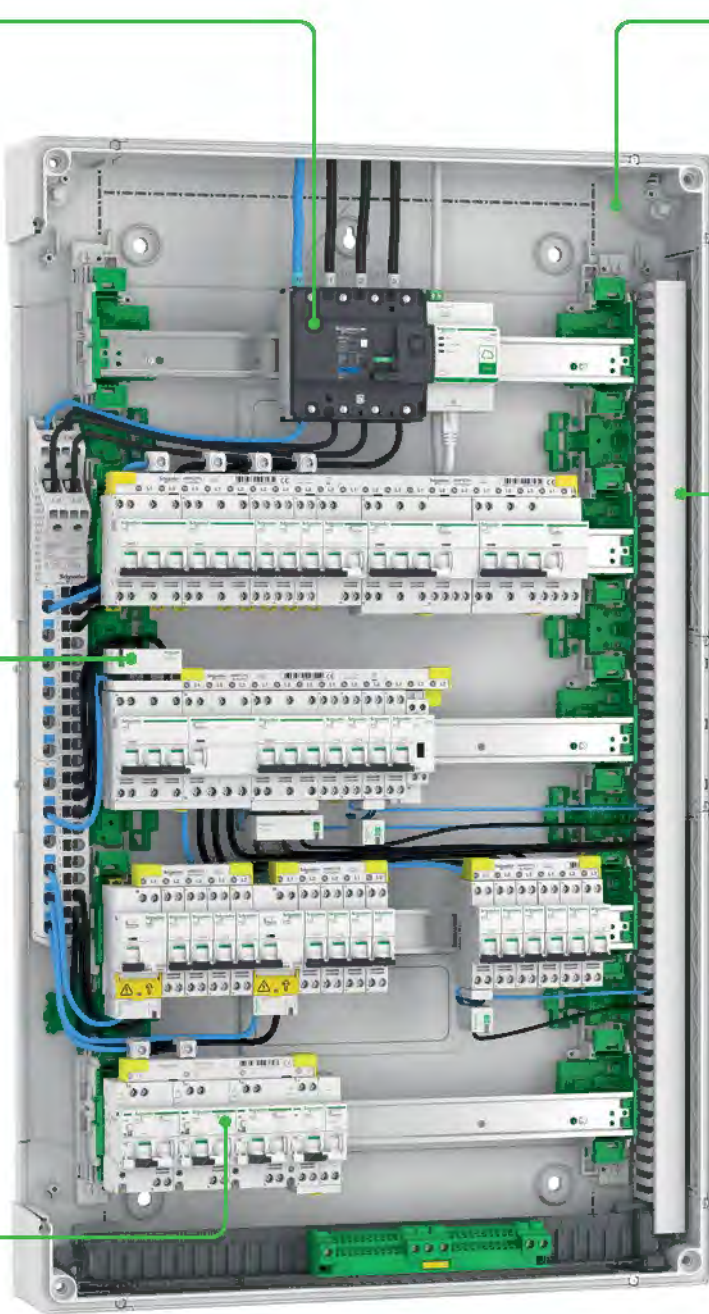

PrismaSeT XS:

PrismaSeT XS enclosures and solutions offering up to 125 A, allow electricians to find the more adapted solution for any installation on an XS building with maximum space for cabling and ease of installation.

Technical Data

- Conformity to IEC 61439-1, 2 & 3
- White RAL 9003
- IP30 & IK08 without door and IP41 & IK09 with door
- Metal and plastic material Class 2 enclosure
- Flush version available for concrete and hollow wall installation

A complete system easy to choose for a full peace of mind **up to 160 A**

Ergonomy

PrismaSeT S is bringing cabling comfort for Electricians & Panel Builders

- All sides removable for the best accessibility
- Removable Din Rails with adjustable interaxis
- Terminal Block for SPD cabling
- Cable ring included

Vertical distribution

The new VDIS 160 allows easiness for connecting main incomer (like NSXm) thanks to the flexible cables 160 A delivered with the product.

It ensures a fast & simple distribution, thanks to a direct and frontal access to head of groups/groups of devices.

Lateral Duct

PrismaSeT S can be delivered with a preassembled & reversible lateral duct, available from 6 to 8 rows.

The vertical load terminal block dissociates the panel's cabling & loads, and optimizes space inside the panel.

The main incomer can be installed in the lateral duct.



- A
- B
- C
- D
- E
- F
- G
- H
- I
- J

General overview

PrismaSeT S

A

We provide you with a complete system for S building architecture

B

Main incomer: Compact NSXm

The ComPact NSXm is the optimized MCCB Head of group with up to 160 A. It can be mounted at your convenience for better flexibility and directly connected to VDIS thanks to the flexible cable.

C

PowerTag

PowerTag Energy is a compact and easy-to-install Class 1 Wireless communication energy sensor that monitors and measures energy and power in real time. It also sends alerts in the event of an electrical anomaly so business owners can count on PowerTag Energy for operational efficiency and uptime.

D

E

F

G

Acti9 iC40

New Acti9 iC40 18 mm Phase Neutral modular system for final distribution provides unmatched performance when it comes to simplifying installation, speed, space-saving as well as ease of maintenance and upgradation.

H

I

J

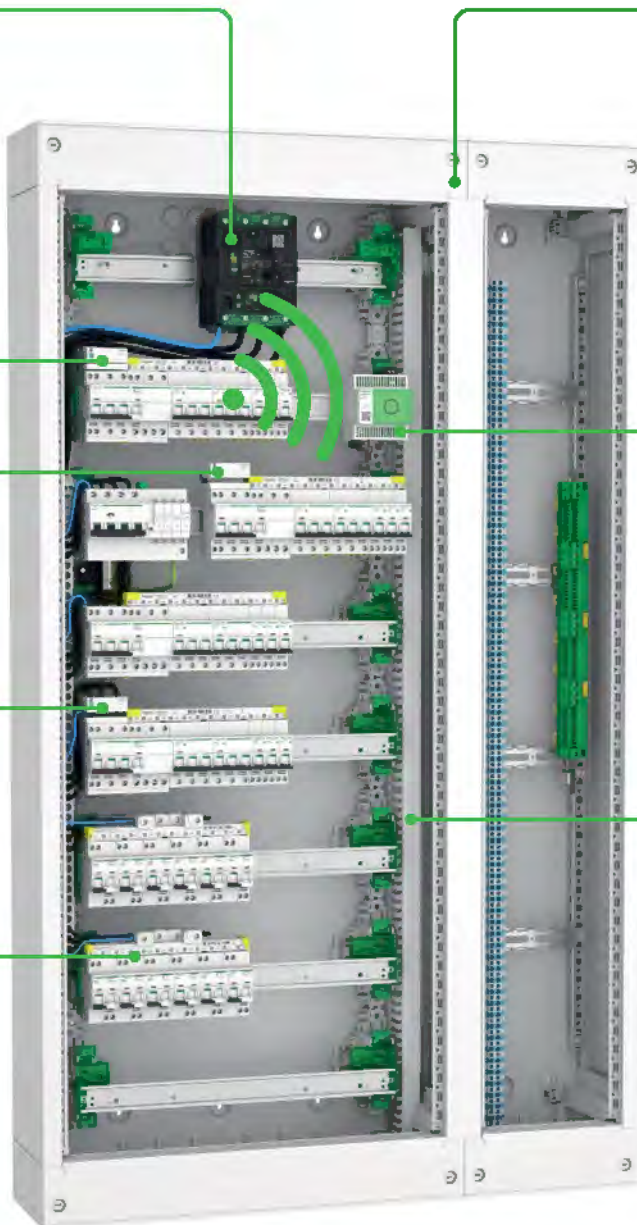

PrismaSeT S:

PrismaSeT S enclosures and related solutions up to 160 A, enable electricians' autonomy to set the electrical distribution in commercial and industrial buildings, making its installation similar to that of residential buildings.

Digital connected solution

Is the new emergency light, connected wirelessly to the Panel Server.

Technical Data

- Conformity to IEC 61439-1, 2 & 3
- White RAL 9003
- IP30 & IK08 Without door & IP41 & IK09 with door
- Metal and plastic material Class 2 enclosure



Learn more about PrismaSeT range here



PrismaSeT XS offer



PrismaSeT S offer

Scan or click on QR code

If you need more details about product references and availability, please check your local Schneider Electric contact <https://www.se.com/ww/en/work/support/country-selector/contact-us.jsp>

- A
- B
- C
- D
- E
- F
- G
- H
- I
- J

A

B

C

D

E

F

G

H

I

J



PrismaSeT I: IEC 61439 Certified, Floor Standing and Wall Mounted Switchboards

Robust by Nature, Refined by Design

Driving Potential Across the Value Chain

An innovative solution based on the experience, expertise, and switchgear offerings of a global specialist in energy management. The perfect solution for tested and IEC-compliant low voltage switchboards.



Improve continuity
of service



Secure infrastructure
& personnel



Control deadlines
& costs

Furthering a Global Legacy of Reliability

The PrismaSeT has set new benchmarks of quality and innovation for over 40 years. This journey of evolution is powered by a committed vision to drive value for partners and end users across the world.

Global Offer - An international influence

PrismaSeT complies with the IEC 61439-1 & 2 standards: an international dimension.



PrismaSeT I

Accelerate your Business with Confidence

A



Design & Customise Faster

PrismaSeT I solutions correspond seamlessly to building needs, enabling you to design faster and implement better.

- Organisation by functional units, each corresponding to an application in the building.
- Organisation by dedicated physical zones for functional units, distribution and connection.

B

C



Make Tasks Easier

Straightforward organisation empowers you to drive efficiency in your process and deliver with speed and accuracy.

- Zone-wise structuring of components.
- Convenient connections for easy upgrades.

D

E

F

G

H

I

J



Optimize Costs & Deadlines

Cutting-edge tools to standardize component selection and drive faster processes help you stay ahead of deadlines and manage costs.

- Design switchboards using tested architectures to meet stringent specifications.
- Optimize selection of components for faster design processes.



Upgrade Without Compromise

A prefabricated system that's rigorously tested and easy to upgrade allows you to build the design and build the right switchboard for your customers.

- Cubicles combine easily with switchboards already in service.
- Devices can be replaced or added at any time.

Powerfully Built, Perfectly Crafted

Low voltage power distribution switchboard system for up to 4000 A

The new PrismaSeT I range boasts new robust designs that maximize power availability, safety against arc faults and environmental damage, efficiency, and performance. Stringently tested to rigorous global standards, the comprehensive range offers a power distribution solution that meets the needs of all electrical installations up to 4000 A.

All power distribution needs covered

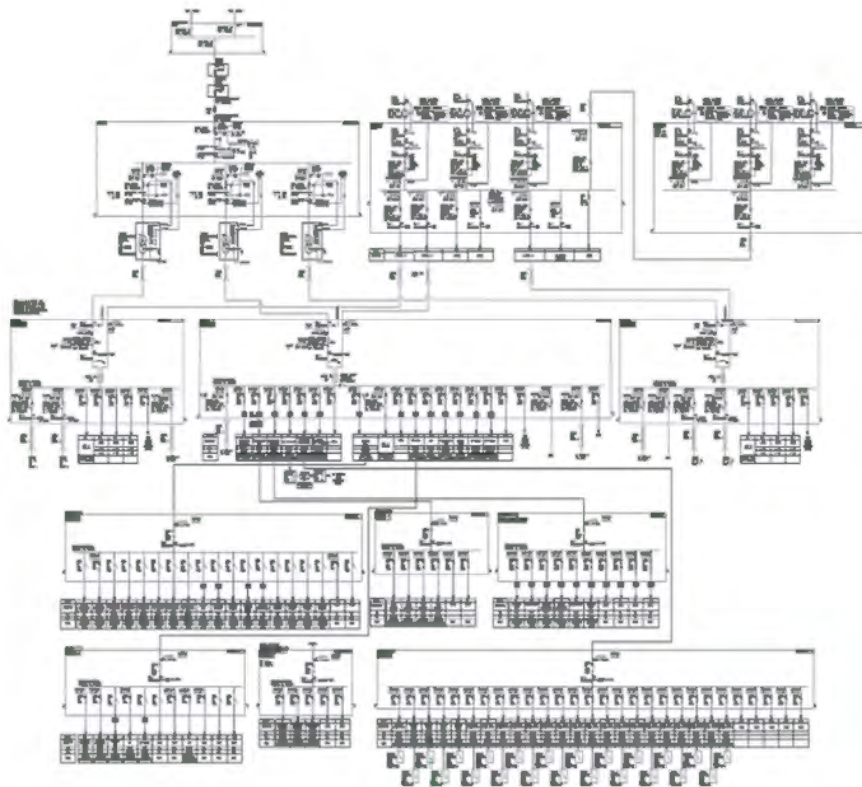

PCC	MCC	Wall Mount	APFC	Advanced Solution
High-power incomers, feeders and source transfer solutions up to 4000 A	Tested configuration up to 110 kW DOL, VFD and SS	Up to 630 A	<ul style="list-style-type: none"> - Up to 500 kVAR per column (without detuned reactor) - Up to 300 kVAR per column (with detuned reactor) - Tested configuration in accordance with IEC 61921 	Scalable architectures for intuitive Switchboard health monitoring, power and energy management

- A
- B
- C
- D
- E
- F
- G
- H
- I
- J

PrismaSeT I

A

Fostering Safety, Efficiency and Reliability



Safe

- Best solutions for protection & metering
- Fire prevention with HeatTag
- Tested for impact IK10, seismic level 2g
- IP20 protection with the door open

Reliable

- Global offer
- Design-quote-build journey made easy with EasyPrisma software
- Prefabricated kits



B

C

D

E



Compliant

- 100% certified by global certification agency
- Internal Arc withstand as per IEC 61641 TR
- Seismic withstand as per IEEE693
- Tested for APFC bank as per IEC 61921
- Green Premium Certified

Future-Ready

- Digital connectivity
- Elegant design with glass door
- Scalability



F

G

H

I

J

Indoor floor standing system



Electrical characteristics

Rated insulation voltage U_i (V AC)	1000
Rated operation voltage (V AC)	Up to 415
Rated impulse withstand voltage (kV)	12
Frequency (Hz)	50/60
Main busbar rated current max. I_e (A)	4000
Rated short-time withstand current (kA/1 s.)	50 kA for up to 2500 A, 65 kA above 2500 A
Rated peak withstand current I_{pk} (kA)	105 kA for up to 2500 A, 143 kA above 2500 A
Neutral network	TNC <input checked="" type="checkbox"/> TNS <input checked="" type="checkbox"/> IT <input checked="" type="checkbox"/> TT <input checked="" type="checkbox"/>
Internal Arc Containment	50 kA for 0.3 Sec
	Arcing Class C
	Tested for I_p & I_{pc} Arc
	Tested on HBB - VBB - Outgoing cable chamber
	IP42 & IP54

Indoor wall mounted system



Electrical characteristics

Nominal rated current (A)	630
Rated insulation voltage U_i (V AC)	1000
Rated operation voltage (V AC)	415
Rated impulse withstand voltage (KV)	8
Frequency (Hz)	50/60
Main busbar rated current max. I_e (A)	630
Rated short-time withstand current (kA/1 s.)	36
Rated peak withstand current I_{pk} (kA)	75.6
Neutral network	TNC <input checked="" type="checkbox"/> TNS <input checked="" type="checkbox"/> IT <input checked="" type="checkbox"/> TT <input checked="" type="checkbox"/>

Technical Characteristics

PrismaSeT I

Copper

Indoor floor standing system



Electrical characteristics

Rated insulation voltage U_i (V AC)	1000
Rated operation voltage (V AC)	Up to 415
Rated impulse withstand voltage (kV)	12
Frequency (Hz)	50/60
Main busbar rated current max. I_e (A)	3200/4000/4280
Rated short-time withstand current (kA/1 s.):	
without Linergy (kA/1 s.)	85
with Linergy (kA/1 s.)	100
Rated peak withstand current I_{pk} (kA)	220
Neutral network	TNC <input checked="" type="checkbox"/> TNS <input checked="" type="checkbox"/> IT <input checked="" type="checkbox"/> TT <input checked="" type="checkbox"/>
Internal Arc Containment	65 kA for 0.5 Sec Arcing Class C Tested for I_p & I_{pc} Arc Tested on HBB - VBB - Outgoing cable chamber IP42 & IP54

Indoor wall mounted system



Electrical characteristics

Nominal rated current (A)	630
Rated insulation voltage U_i (V AC)	1000
Rated operation voltage (V AC)	415
Rated impulse withstand voltage (KV)	8
Frequency (Hz)	50/60
Main busbar rated current max. I_e (A)	630
Rated short-time withstand current I_{sc} (kA/1 s.)	25
Rated peak withstand current I_{pk} (kA)	53
Neutral network	TNC <input checked="" type="checkbox"/> TNS <input checked="" type="checkbox"/> IT <input checked="" type="checkbox"/> TT <input checked="" type="checkbox"/>



Learn more about
PrismaSeT I
range here



Scan or
click on
QR code

Offer

If you need more details about product references and availability, please check your local Schneider Electric contact
<https://www.se.com/ww/en/work/support/country-selector/contact-us.jsp>

- A
- B
- C
- D
- E
- F
- G
- H
- I
- J

A

B

C

D

E

F

G

H

I

J



PanelSeT, ClimaSys

Electrical enclosures for demanding environments

Shelter your electrical equipment in controlled, secured, qualitative, and protected operating conditions. From small boxes to large floor-standing cabinets, PanelSeT electrical enclosures suit all applications in industry or infrastructures. In addition, ClimaSys thermal solutions keep inside temperature and humidity under control to maximize lifespan of all electrical and electronic components.

[se.com/enclosures](https://www.se.com/enclosures)



Sustainability

Made from recycled material and renewable energy sources, delivered with sustainable packaging, the PanelSeT enclosures contribute to reduce CO2 emissions.



Protection

Keep people, controls, and electronic components protected in all environments.



Flexible solutions

Wide range of products and accessories, customisation services to fit any need, easy-to-install system.



Thermal management

Process reliability and operating efficiency thanks to control over temperature and humidity inside automation and control panels.

How to define an enclosure solution?

Invariables

Switchgear and Controlgear are the cornerstone of any electrical system - in industry, infrastructure, building, energy, transport or any other segment. The correct enclosure and thermal management selection is crucial to guarantee the targeted performance. Safeguards of equipment installed inside ensure service continuity.

Correct selection of enclosure and thermal solution

Many influences must be considered when defining an enclosure system. Three groups may be distinguished:

- Protection (equipment and people)
- Thermal management
- Solution profitability.

Ambient conditions and enclosure

The table below is only indicative and not binding. It shows, in a general concept, the optimized performance of the ranges of Universal Enclosures according to the ambient conditions, taking into account technical and commercial criteria:

- ■ ■ Highly recommended
- ■ Recommended
- Not suitable

Ambient condition	Steel	Steel Heavy-Duty	Stainless-steel 304L	Stainless-steel 316L	Stainless-steel 316L Paint	Polyester	Polyester Heavy-Duty
Indoor clean environment ^[1]	■ ■ ■	■	■	■	■	■	■
Difficult cleaning process ^[2]	-	-	■ ■ ■	■ ■ ■	-	-	-
Outdoor (no public access)	-	■ ■ ■	■	■	■	■ ■ ■	■ ■ ■
Outdoor (public access)	-	■	■	■	■	■	■ ■ ■
Harsh chemicals	-	■	■ ■ ■	■ ■ ■	■ ■ ■	■ ■ ■	■ ■ ■
Solar radiation	-	■ ■ ■	-	■ ^[4]	■ ^[4]	■ ■ ■	■ ■ ■
Sand storms	-	-	■ ■ ■	■ ■ ■	-	■	■
Temperature > 40 °C ^[3]	■ ■ ■	■ ■ ■	■ ■ ■	■ ■ ■	■ ■ ■	■ ■ ■	■ ■ ■
Temperature < 5 °C ^[3]	■ ■ ■	■ ■ ■	■ ■ ■	■ ■ ■	■ ■ ■	■ ■ ■	■ ■ ■
Salty environment	-	-	-	■ ■ ■	■ ■ ■	■ ■ ■	■ ■ ■
Sea water splashes	-	-	-	■ ■ ■	■ ■ ■	■ ■ ■	■ ■ ■
Humidity > 70% ^[3]	-	■ ■ ■	■ ■ ■	■ ■ ■	■ ■ ■	■ ■ ■	■ ■ ■
Impact	■ ■ ■	■ ■ ■	■ ■ ■	■ ■ ■	■ ■ ■	■ ■ ■	■ ■ ■
Vandalism	-	■ ■ ■	■	■	■	■	■ ■ ■
Burglary	-	■ ■ ■	■	■	■	■	■ ■ ■
Strong pollution	■	■ ■ ■	■ ■ ■	■ ■ ■	■ ■ ■	■ ■ ■	■ ■ ■
Vibration (marine application)	■ ■ ■	-	■ ■ ■	■ ■ ■	■ ■ ■	■ ■ ■	-
Seismic activity	■ ■ ■	-	-	-	-	-	-
Electro-magnetic interference	■ ■ ■	-	-	-	-	-	-

[1] Not considering F&B process.
[2] e.g. F&B process.

[3] Always using ClimaSys solutions.
[4] Marine solar plants.

Thermal management

The thermal management system must ensure the temperature and humidity control inside the enclosure.

The correct solution must be based on a robust process starting with the diagnosis of the ambient conditions, going to the parameters calculations and defining the best architecture (enclosures + equipment installed + thermal solution).

ProClima is the calculation tool to design the optimal ClimaSys thermal management solutions.



Universal enclosures

Material Matters: Choosing the Right Enclosure for Your Needs

We offer a comprehensive range of enclosures designed to meet diverse industrial and commercial needs. Our enclosures are available in three primary materials - steel, stainless steel, and plastic - each offering unique benefits tailored to specific environments and applications.

A

Steel

Robust Protection and Durability for Industrial Environments

Steel provides high resistance to mechanical stress and corrosion, making it well-suited for use in demanding mechanical plants, particularly for safeguarding electric and electronic components from dust, oil splashes, and impacts.

Thanks to their robustness, durability and ability to protect sensitive equipment from harsh environmental conditions, steel enclosures are commonly used in:

- Manufacturing and Industrial Facilities,
- Power Generation and Distribution,
- Oil and Gas Industry,
- Transportation and Infrastructure.

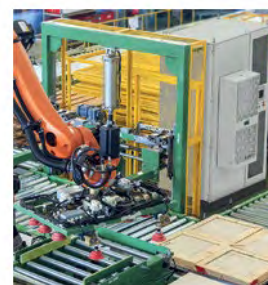

B

C

D

Delving into Low-Carbon Steel: we are making a gradual shift towards utilizing low-carbon steel for our enclosures, following the pioneering example of the PanelSeT SFN cabinet. Crafted from 50% recycled steel in an electric arc furnace powered with 100% renewable electricity, this initiative has significantly reduced the carbon footprint by up to 34% compared to its previous version, while retaining the robustness and durability properties.

E

Stainless-Steel

Hygiene and corrosion-resistance

Stainless-steel provides superior corrosion resistance, making it suitable for use in highly corrosive environments, such as marine, chemical, and food processing industries. It's also known for its hygienic properties, making it suitable for applications requiring strict cleanliness standards. Stainless-steel enclosures

are particularly recommended in the following industries:

- Food and beverage
- Pharmaceuticals
- Petrochemicals
- Infrastructure



F

G

H

Plastic (Polycarbonate, Polyester, ABS)

Rugged Reliability for Outdoor and Harsh Environments

These insulating materials offer lightweight and cost-effective solutions for indoor and outdoor applications where non-corrosive, non-conductive, and easy-to-install enclosures are needed. It is suitable for protecting electrical installations exposed to direct sunlight, rain, saline mist, extreme temperatures, oil splashes, chemical or corrosive agents, and public contact. It's often used in industries such as:

- Power Generation and Grid including Photovoltaic applications,
- Telecommunications,
- Automotive and eMobility,
- Residential applications.



I

J

Our Product Ranges

Discover our universal enclosure solutions, versatile ranges of cabinets and thermal management equipment offering robust protection for electrical and electronic equipment, ensuring safety and reliability. With a variety of sizes, materials, accessories and customization options, we offer flexible solutions for your specific applications.

Steel

PanelSeT



From small boxes to large suitable floor-standing enclosures, PanelSeT steel ranges offer a fit for indoor clean industry and extensive options and easy-to-use accessories to help saving time.

PrismaSeT for Industry



Panel building system for power distribution switchboard dedicated for harsh environments, distributing up to 4000 A (PrismaSeT HD) or up to 6300 A (PrismaSeT 6300).

Actassi



Wall-mounting enclosures for IT applications (voice, data and image), hosting switches and servers in 19-inch racks, for commercial buildings and micro data centers.



[SEE THE VIDEO](#)

Stainless-Steel

PanelSeT



Our stainless-steel boxes, wall-mounting or floor-standing enclosure ranges offer the optimal solution for cleanliness-sensitive or highly corrosive environments.

Available in two grades:

- 304L stainless-steel commonly used in food production settings,
- 316L stainless steel (marine-grade) for saline or chlorinated environments.

Thermal Management



[SEE THE VIDEO](#)

ClimaSys



Maintaining the right temperature inside your enclosure is vital for maximizing the lifetime of your installed devices.

Our ClimaSys range offers you the right solution: airing, connected cooling or heating, including control units for temperature, humidity and many other parameters.

Plastic

PanelSeT



Select the most suitable insulating material and pick customizable enclosures that will serve your business effectively:

- Polyester and polycarbonate modular boxes,
- ABS recycled-content industrial boxes,
- Fiberglass reinforced polyester enclosures to overcome outdoor installation challenges.



[SEE THE VIDEO](#)



Universal enclosures









PanelSeT Enclosures - Standard Applications

Previously Spacial and Thalassa ranges

	Floor-standing	Wall-mounted	Box
A Steel Indoor industrial environments	 SFN - Low-carbon Emission Steel Modular	 SM - Monobloc	 S3D
		 CRN	 SDB - Junction Box
			 SBM - Industrial Box
B Stainless-Steel Hygiene and corrosion-resistance	 SFX - Modular	 SMX - Monobloc	 S3X - Wall-Mounted
			 SBX - Box
C Insulating Material Outdoor infrastructure and industry	 PLA - GRP	 PLM - GRP	 PLS GRP
			 TBS Recycled ABS
			 TBP Polycarbonate

PanelSeT Enclosures - Specific Applications











Previously Spacial and Thalassa ranges

	Floor-standing	Wall-mounted
D Electrical Distribution	 PrismaSeT HD and 6300 Power Distribution Switchboards up to 6300 A	 S3DM - For Modular Switchgear
		 S3DB - For Terminal Blocks
E Motor Control Center	 SFN MCC - Compartmentalized Enclosure	
F Human Machine Interface	 SFN PC - Suitable Control PC Rack	 SD - Control Desk
		 S3CM - Control Enclosure with Suspension System
G Network and Server	 SFN IT - Procured in Kit	 Wall-mounted Racks
		 Actassi OPB and KDB For commercial building
H Severe Outdoor	 PHD - GRP	 SFN HD
		 S3HD
I Seismic Environments	 SFN 3G/6G	 S3D 6G
J Explosive Atmosphere		 S3DEX
Electro Magnetic Compatibility	 SFN HF	 S3HF

General overview

Universal enclosures















ClimaSys - Thermal Management

Cooling	 Natural Airing  Smart Ventilation System  Forced Ventilation  Air-to-Water Exchangers  Air-to-Air Exchangers  Cooling Units
Heating	 Resistance Heaters  Aluminum PTC Heater  Ultra Thin Resistance Heater
Controlling	 Smart Thermal Controllers  Thermal Controllers

ProClima Web
 Designing the suitable thermal solution for your control panels.
 Fully integrated into SEE Electrical from ETAP





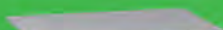

Accessories and Spare parts

Installation Enclosures composition and installation	 Canopy and Roofs  Panels - Side, Partition, Coupling  Floor Accessories  Fixing Accessories  Lifting
Cable Management Outside and inside the enclosure	 Cable Entries  Cable Holding
Mounting For components assembly	 Assembly - Mounting Plates, Cross Rails, Uprights, Chassis...  Electrical Distribution Modular Chassis Busbar...  Door - Door Switch, Internal Doors Hinge and Closing...  Maintenance Paint, Lighting
Spare Part	 Cable Gland Plate  DOORS - Doors + Accessories  Fixing Devices  Roof Accessories

Online Product Selector
 Find accessories that suit your enclosure



PanelSet Customization Services

Customization Services	 Machining Drilling, Milling, Deburring  Painting Finishing  Accessories Fitting  Expert Support for Advanced Projects
<p>Custom Enclosure Configurator Online customization, price quote and delivery lead time</p> 	

General overview

Universal enclosures

Quickly select the right product, its components and accessories, or configure your enclosure solutions to suit your specific needs with our easy-to-use and free digital tools.

A

Product Selector



Save time by finding the exact product references of a selected range and its compatible components and accessories.

No need to log in, enjoy easy and error-free compatibility selection in just a few clicks.



Access our full catalogue of Universal Enclosures and Thermal Management ranges directly from www.se.com website:

- Library of product data sheets, technical documentations, catalogues and brochures
- Product Certificates
- 2D and 3D drawings
- FAQ, technical and Commercial Support



B

C

D

E

ProClima Web



Design the optimal thermal management solution for your control panels and keep up the health of electric and electronic devices inside your enclosures.

ProClima web tool features:

- 2 advanced algorithms for indoor and outdoor calculations
- Thermal databases with >10.000 weathering outdoor stations
- Mechanical compatibility between thermal solutions and enclosure
- Enclosure drawings to preview panel design
- Fully integrated into SEE Electrical from ETAP



Discover ProClima



SEE THE VIDEO



F

G

H

Custom Enclosure Configurator (CEC)

Custom Enclosure Configurator (CEC) allows to adjust enclosures to your specifications in a couple of minutes, instantly returning price quotation and delivery lead times.

It's a convenient, simple-to-use tool that gives you a wide variety of options to choose from, from different cutout shapes to paint colors and accessory fittings.

Available in France, Spain, Germany, Netherland and UK since 2023.



Custom
Enclosure
Configurator
(CEC)



SEE THE VIDEO



Customization Services



Enclosure preparation takes precious time away from actual panel building

Preparing your enclosure can take a significant amount of time and manual labor. Not only that: achieving a high-quality final result can be challenging.

This work can make you lose time on tasks such as:

- Drilling cut-outs for push-buttons, light indicators and cable entries
- Adding device fitting plates and cable glands
- Milling
- Deburring
- Painting

That's where Schneider Electric's PanelSeT enclosure customization services fit in. We can insource the low-value customization work and get it done quickly for you. That way, your enclosures are ready for wiring when they arrive, saving your time and reducing costs, whilst improving the quality of your panels.

To Define your Basic Customization Projects, Choose the Custom Enclosure Configurator (CEC)

Specify settings and get a quote in a single tool, then email your order in

For basic customization work (see next page for advanced customization), the Custom Enclosure Configurator allows you to adjust the enclosure to your specifications in a couple of minutes. And it provides you with a price quote and delivery lead time.

It's a convenient, simple-to-use tool that gives you a wide variety of options to choose from, from different cut-out shapes to paint colors and accessory fittings.

To Define Complex Customization Projects, Contact our Experts

For complex projects requiring advanced customization, a dedicated team of Schneider Electric experts will guide you through the process

Here's an outline of our advanced customization process:

- Provide your specifications
- Get a feasibility study and quotation
- Confirm and place your order
- Manufacturing starts
- A quality assessment is performed
- Your product is delivered

For more information, consult the Customization Services Guide



Universal enclosures

Customization Solutions in a Nutshell

A



Time Savings

Delivered with cut-outs and painting: no waste of time



Logistics

- Flexible management of your logistics option (scheduled delivery service for on-going orders)
- Special packaging

B

C



Simplified Installation

Enclosures delivered with cut-outs: no special tools required



Ergonomic Design

Customized project dedicated to your personal requirements

D

E



Increased Life-Time

- Cut-outs made before painting ensure corrosion protection and reliable sealing
- Painting service for better protection



Improved Quality

- No burrs on edges of cut-outs
- Help guarantee manufacturing tolerances

F

G



Aesthetics

- Large choice of colors
- No scratches in external surfaces



Higher Performance

- Adapted thermal management
- Higher-grade stainless-steel

H

For any information, refer to the Customization Services Guide
 Ref : UEMKUG002EN



I

J



Learn about more Universal enclosures range here



Offer



Catalogue

Scan or click on QR code

If you need more details about product references and availability, please check your local Schneider Electric contact <https://www.se.com/ww/en/work/support/country-selector/contact-us.jsp>



Smart Panel assembly guide

A

B

C

D

E

F



An Assembly Guide for Panel Digitalization for Commercial and Industrial Buildings

Connected Products make the base layer of EcoStruxure solutions and are essential to make your panel a Smart Panel (also known as a connected panel or digital panel).

To get the benefits from EcoStruxure Power, it is essential to add connectivity to your panel.

There are several ways to connect a panel, and keep in mind that only what is measured can be managed. Connectivity can range from a simple I/O module to connecting multiple sophisticated products with communication via wireless and/or wired communication. Thus, the benefits of EcoStruxure Power will depend on how the panel is connected, including which products are used, how the information is transferred to the two top layers of EcoStruxure (Edge Control and Apps, Analytics and Services), and finally which software solution is used as well as how it is set up.

As an example, an Indication Auxiliary (OF/SD) in a ComPacT™ NSX circuit breaker can give you the status of your circuit breaker, but not information regarding recent events, energy measurements or information on the power quality.

Connectivity can be added in a new panel (Greenfield) or a preexisting panel (Brownfield).

Adding connectivity in an existing panel can sometimes be complicated, as there could be additional space restrictions, as well as an impact if downtime is needed to work on the panel.

Nevertheless, there are solutions that make it easier to add connectivity in these types of panels.

For more information, consult the assembly guide

Ref : ESXP1G003EN



Circuit breakers and switches

MasterPact MTZ	
General overview	B-100
Select your circuit breakers	B-104
Select your MicroLogic X control unit.....	B-106
Usefull links.....	B-108
MasterPact MTZ Active	
General overview	B-110
Select your circuit breakers	B-116
Select a MicroLogic Active Control Unit.....	B-118
ComPact NS	
General overview	B-120
ComPact NSX & NSXm	
General overview	B-128
General characteristics.....	B-132
Usefull links.....	B-134
ComPact INS & INV	
General overview	B-136
Selection guide	B-140
ComPact NSX DC EP	
General overview	B-142
TransferPact	
General overview	B-144
EasyPact MVS	
General overview	B-150
General characteristics.....	B-154
EasyPact MVS New Energy	
General overview	B-156
General characteristics.....	B-161
EasyPact EZC	
General overview	B-162
General characteristics.....	B-164
Usefull links.....	B-166
EasyPact CVS	
General overview	B-168
General characteristics.....	B-173
Usefull links.....	B-175
EasyPact Solar MCCB	
General overview	B-176
General characteristics.....	B-181



NOW, YOU'RE READY...

Built on the legendary performance and reliability of the MasterPact range

MasterPact MTZ circuit breakers prepare you for the future of power distribution with smart connectivity, remote monitoring, and easy customization via digital modules.

- Intuitive EcoStruxure™ Power Device App smartphone app for easy operation and maintenance
- Precise Class 1 power meter built in for energy-saving capabilities
- Easy customization with digital modules.
- Intuitive MicroLogic™ X control unit
- Easy installation using established architectures
- Seamless integration with building and energy management systems with EcoStruxure™ architectures
- Designed and tested to applicable standards for ANSI, UL, and IEC
- Low migration cost from MasterPact NT/NW to MasterPact MTZ.



With MasterPact MTZ breakers, enhanced performance and connectivity equip you for the future of power distribution.

Available from 630 A to 6300 A.



SEE THE VIDEO

...FUTURE READY

With MasterPact MTZ air circuit breakers, you're ready for all the ways power distribution is changing. Smart connectivity gives you real-time data to help avoid downtime. Digital modules allow you to customize the circuit breaker to your specific needs. And proven durability gives you the assurance that you're placing your power distribution on a reliable foundation.

MasterPact MTZ circuit breakers are available in three sizes:

MTZ1

From 630 to 1600 A



MTZ2

From 800 to 4000 A



MTZ3

From 4000 to 6300 A



Now featuring digital modules to customize MicroLogic X control units

2.0 X (LI) | 5.0 X (LSI) | 6.0 X (LSIG) | 7.0 X (LSIV)

Downloadable digital modules provide enhanced:

- Protection: Energy Reduction Maintenance Settings, Ground-fault alarm, Under/Over voltage protection, Under/Over frequency protection, Reverse active power protection, IDTML overcurrent protection, Directional overcurrent protection
- Measurement: Energy per phase, Individual harmonics analysis
- Maintenance & Diagnostics: Power restoration assistant, MasterPact operation assistant, Wave form capture on trip event, Modbus legacy dataset, IEC 61850 for MasterPact MTZ.



MasterPact MTZ

A

Innovation at every level

Whether you're a panel builder or a contractor, Master**Pact** MTZ circuit breakers offer the innovative features you need to streamline system design, construction, and operation.

B

I build



Install and retrofit easily

The transition from MasterPact NT/NW to Master**Pact** MTZ air circuit breakers merges installation ready design with future ready evolutions in smart connectivity, remote monitoring and easy customization. It doesn't require switchboard modification or IEC 61439-1 and -2 recertification.

Commission quickly

With EcoStruxure™ Power Commission software, you can integrate smart devices, commission connected switchboards, and generate comprehensive reports as part of factory and site acceptance tests.

Provide better service

Our partner programs offer tools, software, support, and loyalty awards to help you grow your business and meet your customers' needs with high-quality pre- and post-sale services.

C

D

E

F

I operate



Improve customer loyalty

Master**Pact** MTZ circuit breakers allow you to provide commissioning and maintenance reports to demonstrate your reliability and value to your customers or employer.

Make maintenance easier

Master**Pact** MTZ circuit breakers send alerts to your smartphone, helping you to diagnose problems quickly and avoid downtime. In case of a power outage, the Power Restoration Assistant digital module guides you to the root cause and helps you restore power quickly.

Increase safety

Because Master**Pact** MTZ circuit breakers can be operated remotely via Bluetooth, operations can occur outside of the arc flash zone. Plus, NFC allows access to stored breaker data even when the power is off.

G

H

I

J

The MasterPact MTZ range covers your protection needs.

Masterpact

Five performance levels
N1 | H1 | H2 | H3 | L1

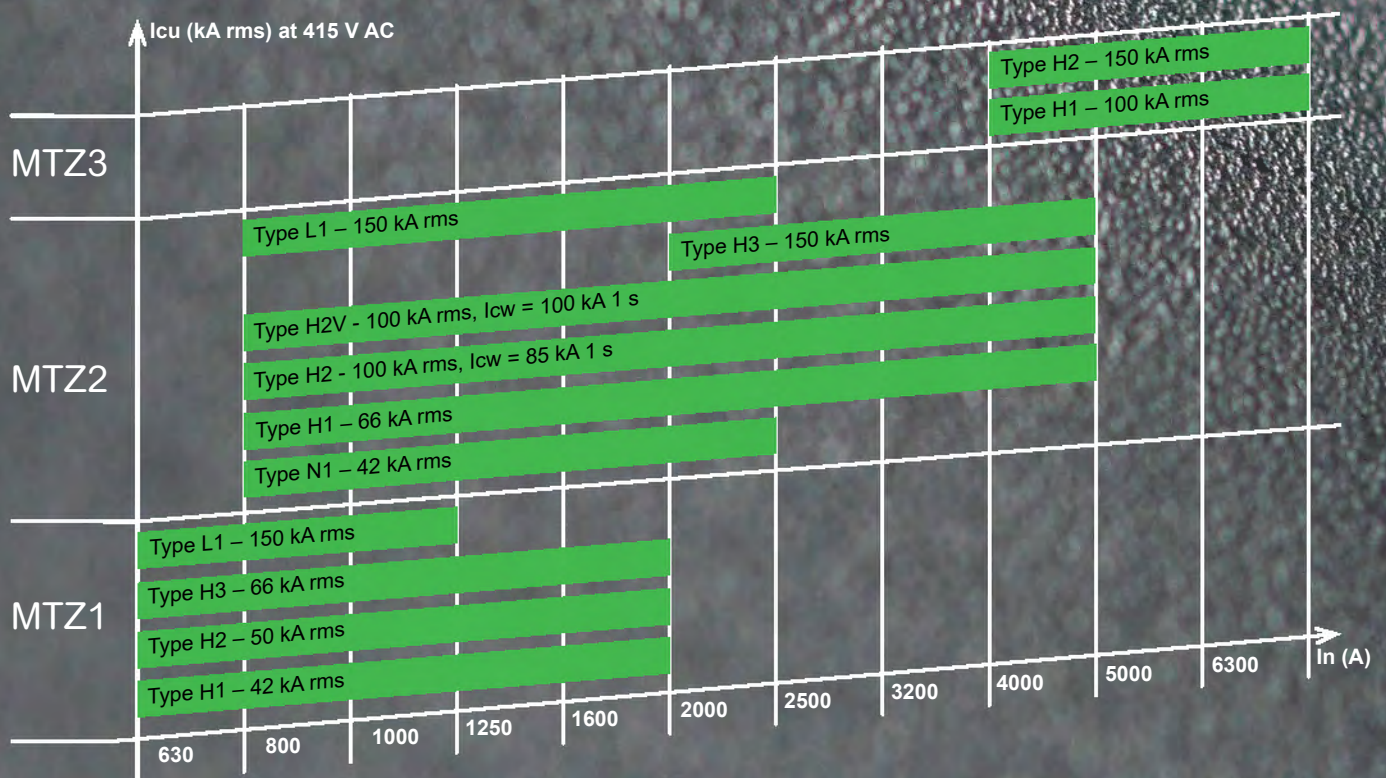

MasterPact MTZ

Circuit breakers

Selection criteria

MasterPact MTZ front face provides reinforced insulation (Class 2) according to IEC 60664-1. It allows Class 2 installation with breaker control from outside.



MasterPact **MTZ1**
From 630 to 1600 A

Safety of operation

Type	H1	H2	H3 ^[8]	L1
Rated current (A) at 40/50°C ^[1]				
MTZ1 06	630	630	630	630
MTZ1 08	800	800	800	800
MTZ1 10	1000	1000	1000	1000
MTZ1 12	1250	1250	1250	
MTZ1 16	1600	1600	1600	

Selectivity category ^[2]

			B	B	B	A
Ultimate breaking capacity V AC 50/60 Hz	I _{cu} (kA rms)	At 440 V	42	50	66	130
		At 1150 V	-	-	-	-
Rated service breaking capacity	I _{cs} (kA rms)	At 440 V	42	50	50	130
		At 1150 V	-	-	-	-
Rated short-time withstand current V AC 50/60 Hz	I _{cw} (kA rms)	0.5 s	42	42	50	10
		1 s	42	42	50	-
		3 s	24	24	30	-
Compliant with IEC/EN 60947-2 Annex H			Yes	Yes	Yes	Yes
Position of neutral (Left: L, Right: R)			L	L	L	L
Type of control unit: MicroLogic X						

Installation characteristics

Type	H1	H2	H3	L1
Connection				
Drawout, front				
Drawout, rear				
Fixed, front				
Fixed, rear				
Dimensions (mm) H x W x D				
Drawout 3P	322 x 288 x 291			
Drawout 4P	322 x 358 x 291			
Fixed 3P	301 x 276 x 209			
Fixed 4P	301 x 346 x 209			
Weight (kg) approximate				
Drawout 3P/4P	30/39			
Fixed 3P/4P	14/18			

[1] 50°C for rear vertical connected only, refer to temperature derating tables for other connection types.

[2] For details on selectivity category A and B, see MTZ Catalogue reference LVPED216026EN.

[3] No front connection for 4000 A.

[4] No horizontal rear connection for 6300 A.

[5] To be specified when ordering.

[6] MTZ2-H10 dedicated to 1250 V systems.

[7] For MasterPact MTZ2-H10 circuit breaker the MicroLogic X control unit cannot be directly connected to the internal voltage pick-up on the downstream terminal. The external voltage pick-up option PTE associated with external voltage transformer shall be used, see MTZ Catalogue reference LVPED216026EN.

[8] For MasterPact MTZ1 H3 and MTZ2 H2V the rated operational voltage is limited to 440 V AC - 50/60 Hz.

Selection guide

MasterPact MTZ

Circuit breakers



MasterPact **MTZ2**
From 800 to 4000 A



MasterPact **MTZ3**
From 4000 to 6300 A

Type	N1	H1		H2		H2V ^[6]		H3	L1	H10 ^[6]	
MTZ2 08	800	800		800		800		800	800	800	
MTZ2 10	1000	1000		1000		1000		1000	1000	1000	
MTZ2 12	1250	1250		1250		1250		1250	1250	1250	
MTZ2 16	1600	1600		1600		1600		1600	1600	1600	
MTZ2 20	2000	2000			2000	2000	2000	2000	2000	2000	
MTZ2 25			2500		2500	2500	2500	2500		2500	
MTZ2 32			3200		3200	3200	3200	3200		3200	
MTZ2 40			4000		4000	4000	4000	4000		4000	
	B	B		B		B		B	B		B
	42	66		100		100		150	150	-	100 150
	-	-		-		-		-	-	50	- -
	42	66		100		100		150	150	-	100 150
	-	-		-		-		-	-	50	- -
	42	66	66	85	85	100	65	30	50	50	100 100
	42	66	66	85	85	100	65	30	50	50	100 100
	22	36	66	50	75	75	65	30	50	50	100 100
	Yes	Yes		Yes		Yes	Yes	Yes	No		Yes Yes
	L	L or R ^[5]		L or R ^[5]		L or R ^[5]	L	L	L		L or R ^[5] L or R ^[5]

N1	H1		H2		H2V	H3	L1	H10	H1	H2

439 x 441 x 403	479 x 786 x 403
439 x 556 x 403	479 x 1016 x 403
352 x 422 x 300	352 x 767 x 300
352 x 537 x 300	352 x 997 x 300
90/120	225/300
50/65	120/160



Select your MicroLogic X control unit

MasterPact MTZ

Overview of functions

A

Measurement

Energy management is the challenge of present & future generations.

To meet this requirement MicroLogic X incorporates all the measuring functions of a power meter including **Energy Class 1 accuracy** third-party certified.

B

C

D

Protection

Improvement of the reliability of MicroLogic X, dual settings and additional facilities **increase the performance and the flexibility** of low voltage systems of protection.

E

F

G

14 Optional 24/7 downloadable digital modules dedicated to upgrading MicroLogic X

- Undervoltage and overvoltage
- Underfrequency and overfrequency
- Reverse active power
- IDMTL overcurrent protection
- Directional overcurrent
- Ground-fault alarm
- Energy Reduction Maintenance Settings
- Energy per phase
- Individual harmonics analysis
- Power restoration assistant
- MasterPact operation assistant
- Waveform capture on trip event
- IEC 61850 for MasterPact MTZ
- Modbus legacy dataset.

H

I

J

Maintenance & Diagnostics

Optimal continuity of services as well as extended life of equipment is one of customers main concerns.

For that purpose **MicroLogic X integrates new extended diagnosis** and assistance to maintenance.



Communication

- It is now common practice to make available most of the information processed by a Protection Control Unit, locally for network operation and maintenance, as well as remotely for higher functions of control, monitoring, energy efficiency and assets management
- To comply with this requirement, MicroLogic X control units **incorporate several channels of communication, including Ethernet, Modbus SL and wireless communication facilities.**

MasterPact MTZ

Overview of functions

> Protection for ...

... MicroLogic 2.0 X

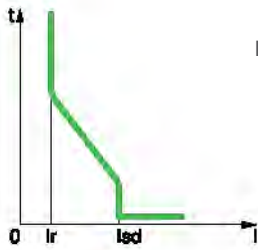

LI: Long-time
+ Instantaneous



... MicroLogic 5.0 X

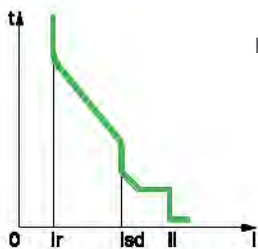

LSI: Long-time
+ Short-time
+ Instantaneous



... MicroLogic 6.0 X

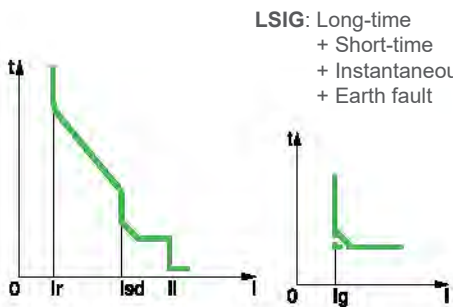

LSIG: Long-time
+ Short-time
+ Instantaneous
+ Earth fault



... MicroLogic 7.0 X

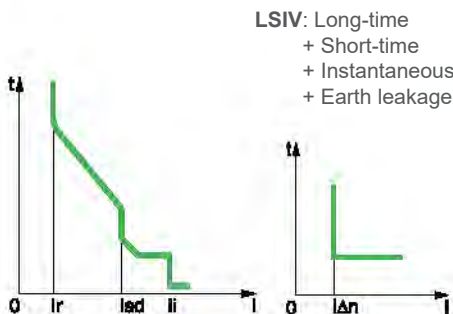

LSIV: Long-time
+ Short-time
+ Instantaneous
+ Earth leakage



> Additional features of protections

Along with the LSIGV protections, new additional features and facilities allow to improve the protection performance of a system when difficulties are met such as low values of the short-circuit current or the need to limit the thermal constraints to the equipment: dual settings, fine settings, zone selective interlock, tripping mode (Standard/Fast).

> Measurement

MicroLogic X measures all electrical parameters of an electrical network: currents, voltages, frequency, power, energy, power factor, current and power demand.

Min/Max and average values are calculated for most of the parameters.

Optional digital modules allow the measurement of energy per phase, and to perform Waveform capture.

> Maintenance & Diagnostics

Diagnostic features are intended to limit the risk of power interruptions and to re-energize the installation as quickly as possible after a trip.

They provide alarms and messages to help the user in scheduling both preventive and predictive maintenance, and device replacement.

> Communication

New generation MicroLogic X control units incorporate wireless technology (Bluetooth and NFC) that allows the transfer of a wide selection of critical information (protection, measurements, Maintenance & diagnostics) to your mobile device, by means of Ecostruxure Power Device App app. Alternatively, MasterPact MTZ can be equipped with ETHERNET communication through either the IFE module or the new embedded EIFE that includes webpages. Modbus SL communication is available through the IFM interface module.

> Optional digital modules

Optional digital modules can be purchased and downloaded to extend the performance of MicroLogic X control units. They are dedicated to Protection, Measurement, and Maintenance & diagnostics, and are available through Go Digital on the Schneider Electric website, open 24/7.

A

B

C

D

E

F

G

H

I

J

MasterPact MTZ

- A
- B**
- C
- D
- E
- F
- G
- H
- I
- J



Learn about more MasterPact MTZ range here



Offer



Catalogue

Scan or click on QR code



If you need more details about product references and availability, please check your local Schneider Electric contact <https://www.se.com/ww/en/work/support/country-selector/contact-us.jsp>

- A
- B**
- C
- D
- E
- F
- G
- H
- I
- J

MasterPact MTZ Active

- A
- B**
- C
- D
- E
- F
- G
- H
- I
- J



MasterPact MTZ™ with MicroLogic Active

Air circuit breakers Ready to Act

With the emergence of Electricity 4.0 and a world that is increasingly digital and electric, customers face complex day-to-day challenges, including 24/7 uptime demands, spiraling energy costs, urgent calls for sustainable practices, and the integration of renewables.

MasterPact MTZ with MicroLogic Active are ready to act to meet these challenges and more.

A legacy of innovation

For 35+ years, the MasterPact name has been synonymous with circuit breaker innovation and performance.

After pioneering digital breakers more than a decade ago, MasterPact continues to lead the way today by offering a new, intuitive control unit with innovative digital features that allow customers to achieve a new benchmark for safety and resiliency while ensuring business continuity.

Energy demands are escalating

40%

Amount of available energy consumed by buildings worldwide

+50%

Level of increase in global industry energy demand by 2050

50 billion

Number of smart, connected devices by 2020

100%

Expected uptime for buildings worldwide

The MasterPact MTZ range covers your protection needs

Five Performance Levels

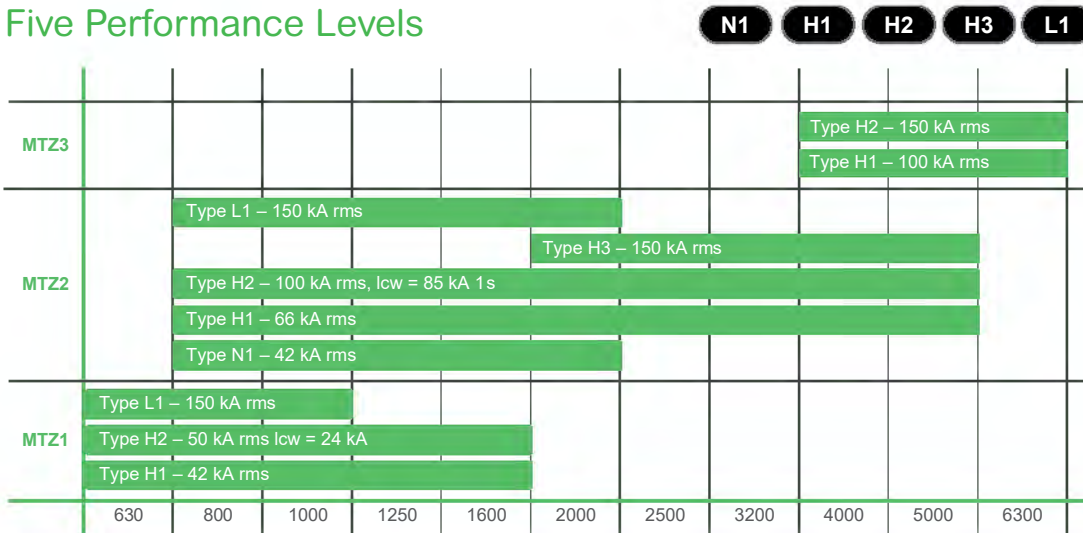

Responding to customer challenges



Companies across industries demand power 24/7. So when an outage occurs, they need to determine the cause quickly. Was it an overload? Short circuit? Equipment ground fault?

Knowing the root cause of an outage allows quick action to restore power and resume normal operations versus enduring lengthy and costly delays.

MasterPact MTZ combines real-time information and ease of use to enable fast mitigation of outage events.

MasterPact MTZ with MicroLogic Active saves time and money

The new MasterPact MTZ's innovative control unit, MicroLogic Active, monitors various breaker functions to provide vital, real-time information, which makes the MasterPact MTZ Active. In the event of a power outage, the breaker lets you scan a QR code on the control unit to quickly identify the cause and determine the best action to take. No need to search through a 200-page document ever again.

With MasterPact MTZ Active, you are ready to act – fast!



MasterPact MTZ Active

Ready to act for **Safety**

MasterPact MTZ Active features safety-enhancing innovations to help protect electrical contractors, building occupants, maintenance personnel, and property. From its Energy Reduction Maintenance Setting to its intuitive control unit, our advanced breaker sets new benchmarks for safe installations and operation.



Energy Reduction Maintenance Settings (ERMS) enhance protection against arc flash hazards

Application-specific integrated circuits (ASICs) increase IP safety, improve reliability, and reduce cost

Fast-trip capability prevents power overloads, safeguarding people and property

Intuitive control unit allows quick setting of all protection functions

Near Field Communication (NFC) provides remote access via a smartphone and the EcoStruxure Power Device app

Keyboard locking feature protects parameter settings by requiring a PIN code for user access

Color LED and LCD indicators facilitate at-a-glance breaker status monitoring

Ready to act for **simplicity** and **flexibility**

With MasterPact MTZ Active, there's no need to change your current design and installation practices – dimensions, footprint, and commissioning procedures all remain the same. And in the event of last-minute trips, you are able to respond immediately.

USB-C port allows **quick setup** and reflects latest communications best practices

User-friendly interface facilitates operation, diagnostics, and maintenance



Alarms can be customized to voltage requirements of different machines and applications

Field-swappable control unit allows last-minute changeouts, eliminating entire breaker replacements and avoiding project delays



Ready to act for **Sustainability**



By partnering for sustainability with Schneider Electric through the installation of MasterPacT MTZ Active, you are helping to minimize impacts on the planet while accelerating our collective journey on the road to net zero.

 <p>Green packaging eliminates single-use plastics and features 100% recycled and recyclable cardboard</p>	<p>Transformer efficiency data helps inform actions to save energy and reduce CO2 emissions</p>
<p>Upgrading with an MicroLogic Active control unit extends the life of installed NT and NW breakers and achieves carbon savings by eliminating the need to replace the entire breaker</p>	 <p>Energy metering tracks power consumption and promotes energy efficiency</p>



Ready to act for **Business Continuity**

Across industries, everyone demands power 24/7. And when outages occur, customers need to determine the cause – fast. MasterPacT MTZ Active is designed allow your customers to achieve new levels of uptime and agility.

 <p>On-site Selectivity Checks ensure power availability and maximize the business continuity</p>	<p>Customizable alarms and event log contribute to uptime optimization</p>	<p>Algorithm-generated notifications facilitate preventive maintenance</p>
 <p>Field-swappable control unit allows last-minute changeouts, eliminating entire breaker replacements and avoiding project delays</p>	 <p>Industry-first QR code solution provides immediate access to the root cause of outages and advises the best action to remedy them</p>	

- A
- B**
- C
- D
- E
- F
- G
- H
- I
- J

MasterPact MTZ Active



Active with EcoStruxure

MasterPacT MTZ Active circuit breakers are part of the Active Panel solution made possible by Schneider Electric's EcoStruxure Power architecture.

By connecting cutting-edge hardware with innovative software, Active Panels provide real-time information that enables users to pinpoint overloads and inefficiencies, make informed decisions to improve operational efficiency, and keep track of a building's electrical system status.

MasterPacT MTZ Active circuit breakers combine with Active Panels to allow:

- Connection to EcoStruxure software to unlock electrical system potential
- Remote monitoring and control with any supervision system to carry out predictive and preventive maintenance
- Remote notifications and maintenance planning with Facility Expert digital maintenance logbook
- Proactive facility management with EcoStruxure Facility Advisor, Power Monitoring Expert, Power SCADA Operations, and Building Operation software
- Asset life-cycle management and condition-based maintenance via equipment monitoring
- Asset and alarm management
- Energy efficiency and power quality management
- Compliance with the latest regulations for energy-efficient buildings



A new digital user experience

With the MasterPact MTZ active circuit breaker, every stage of the project - from designing and configuring to operating and maintaining - is streamlined using its digital capabilities.

DESIGN



EcoStructure Power Design Software
Single-line diagram design software that calculates and sizes your electrical installation.

EcoStructure Power Build Software
Quick configuration and quotation tool for switchboards.

Design with 3rd Party Software
Completely integrated with third party design software to enhance your work efficiency.

CONFIGURE AND ORDER



Product Selector
Configure MasterPact MTZ to save time and ensure accuracy

BUILD AND COMMISSION



EcoStructure Power Commission software
Commission and upgrade easily with protection setting and factory-acceptance test.

OPERATE AND MAINTAIN



EcoStructure Power Monitoring Software
Power Monitoring Expert
Power SCADA Operation
Building Operation
Facility Advisor

se.com

Monitor with EcoStructure Energy Hub Software



Operate with MicroLogic Active control unit
Locally in the facility room

Status "at a glance"



Remote, continuous notifications
Track facility data SESA137086, receive alerts in case of power events and scheduled maintenance.

se.com

Operate with your smartphone
Locally in the facility room



EcoStructure Power Device App

Android

iOS



MasterPacT MTZ Active

Circuit breakers

A

Selection criteria

Safety of operation

MasterPacT MTZ front face provides reinforced insulation (Class 2) according to IEC 60664-1. It allows Class 2 installation with breaker control from outside.



MasterPacT **MTZ1**
From 630 to 1600 A

B

C

Rated current (A) at 40/50 °C ^[1]

Type	H1	H2	L1
MTZ1 06	630	630	630
MTZ1 08	800	800	800
MTZ1 10	1000	1000	1000
MTZ1 12	1250	1250	
MTZ1 16	1600	1600	

D

E

Selectivity category ^[2]

		B	B	A
Ultimate breaking capacity V AC 50/60 Hz	I _{cu} at 440 V (kArms)	42	50	130
	at 525 V	42	42	100
	at 690 V ^[6]	42	42	-
Rated service breaking capacity	I _{cs} (kA rms) % I _{cu}	100%		
Rated short-time withstand current V AC 50/60 Hz	I _{cw} 0.5 s (kA rms)	42	42	10
	1 s	42	42	-
	3 s	24	24	-
Compliant with IEC /EN 60947-2 Annex H		Yes	Yes	Yes
Position of neutral (Left: L, Right: R)		L	L	L
Type of control unit: MicroLogic Active				

F

G

Installation characteristics

Type	H1	H2	L1
Connection			
Drawout, front			
Drawout, rear			
Fixed, front			
Fixed, rear			
Dimensions (mm) H x W x D			
Drawout 3P	322 x 288 x 291		
Drawout 4P	322 x 358 x 291		
Fixed 3P	301 x 276 x 209		
Fixed 4P	301 x 346 x 209		
Weight (kg) approximate			
Drawout 3P/4P	30/39		
Fixed 3P/4P	14/18		

H

I

J

[1] 50 °C only for circuit breakers with rear vertical connections, refer to temperature derating tables for other connection types.

[2] For details on selectivity category A and B, see MTZ Active Catalogue reference LVPED225010EN.

[3] No front connection for 4000 A.

[4] No horizontal rear connection for 6300 A.

[5] To be specified when ordering.

[6] For IT grounding systems, the rating is limited to 600 V AC. For more information, please contact Schneider Electric Customer Care Center.

Selection guide

MasterPacT MTZ Active

Circuit breakers



MasterPacT **MTZ2**
From 800 to 4000 A



MasterPacT **MTZ3**
From 4000 to 6300 A

MasterPacT MTZ2								MasterPacT MTZ3		
Type	N1	H1		H2		H3	L1	Type	H1	H2
MTZ2 08	800	800		800			800			
MTZ2 10	1000	1000		1000			1000			
MTZ2 12	1250	1250		1250			1250			
MTZ2 16	1600	1600		1600			1600			
MTZ2 20	2000	2000			2000	2000	2000			
MTZ2 25			2500		2500	2500				
MTZ2 32			3200		3200	3200				
MTZ2 40			4000		4000	4000		MTZ3 40	4000	4000
								MTZ3 50	5000	5000
								MTZ3 63	6300	6300
	B	B		B		B	B		B	B
	42	66		100		150	150		100	150
	42	66		85		130	130		100	130
	42	66		85		100	100		100	100
100%								100%		
	42	66	66	85	85	65	30		100	100
	42	66	66	85	85	65	30		100	100
	22	36	66	50	75	65	30		100	100
	Yes	Yes		Yes		Yes	Yes		Yes	Yes
	L	L or R ^[5]		L or R ^[5]		L	L		L or R ^[5]	L or R ^[5]

MasterPacT MTZ2								MasterPacT MTZ3	
	N1	H1		H2		H3	L1	H1	H2
	439 x 441 x 403	439 x 556 x 403		352 x 422 x 300		352 x 537 x 300		479 x 786 x 403	479 x 1016 x 403
	90/120	50/65		225/300		120/160			



Select a MicroLogic Active Control Unit

MasterPact MTZ Active

Overview of functions

A

Measurement

Energy management is the challenge of present and future generations.

B

To meet this requirement, MicroLogic Active incorporates all the measuring functions.

C

D

Protection

MicroLogic Active offers a large long-time delay setting range and protection accuracy for a wide temperature range (-25 to +70 °C).

E

F

G

Communication

- It is now common practice to make available most of the information processed by a protection control unit, both locally for network operation and maintenance, and remotely for higher functions of control, monitoring, energy efficiency and asset management.

H

I

J

Maintenance and Diagnostics

Optimal continuity of services as well as extended equipment life are among customers main concerns. For that purpose,

MicroLogic Active control units contribute to corrective, preventive and predictive maintenance.



Image

- To comply with this requirement, MicroLogic Active control units **incorporate several channels of communication, including Ethernet, Modbus SL and wireless communication interfaces.**

Select a MicroLogic Active Control Unit

MasterPact MTZ Active

Overview of functions

> Protection for ...

... MicroLogic Active 1.0

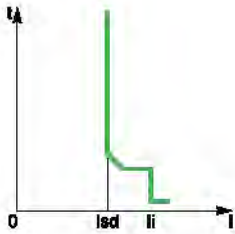

SI: Short-time
+ Instantaneous



> Additional features of protections

Along with the LSIG protections, new additional features and communication interfaces improve the protection performance of a system to manage difficulties such as low short-circuit current values or the need to limit the thermal constraints of the equipment: fine settings, zone selective interlock, tripping mode (Standard/Fast).

... MicroLogic Active 2.0

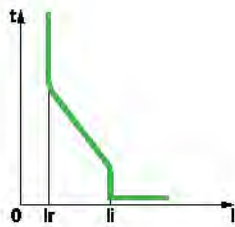

LI: Long-time
+ Instantaneous



> Measurement

MicroLogic Active measures all electrical parameters of an electrical network: currents, voltages, frequency, power, energy, power factor, current and power demand. Min/Max and average values are calculated for most of the parameters.

... MicroLogic Active 5.0

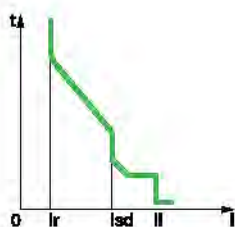

LSI: Long-time
+ Short-time
+ Instantaneous



> Maintenance and Diagnostics

Diagnostic features are intended to limit the risk of power interruptions and to power up the installation as quickly as possible after a trip. They provide alarms and messages to help the user in scheduling both preventive and predictive maintenance, as well as device replacement.

... MicroLogic Active 6.0

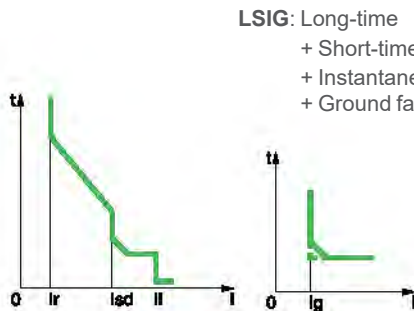

LSIG: Long-time
+ Short-time
+ Instantaneous
+ Ground fault



> Communication

The new generation of MicroLogic Active control units incorporate wireless IEEE technology NFC, and optional Bluetooth that allows the user to send a wide selection of information (protection, measurements, maintenance and diagnostics data) to your mobile device, by means of the EcoStruxure Power Device app. Alternatively, MasterPacT MTZ can be equipped with Ethernet communication through either an IFE module or an embedded EIFE, with webpage visualization. Modbus SL communication is available through the IFM interface module.



Learn about more
MasterPact MTZ Active
range here



Offer



Catalogue

Scan or
click on
QR code

If you need more details about product references and availability, please check your local Schneider Electric contact <https://www.se.com/ww/en/work/support/country-selector/contact-us.jsp>



A

B

C

D

E



F

Molded Case Circuit Breakers and Switch-Disconnectors from 630b to 3200 A

G

The world is becoming more electric, digitized and decarbonized. Our digitized LV products are powered by innovation at every level enabling enhanced connectivity, real-time operations and smart analytics. They bring improved safety and security. They help you to improve reliability and performance – and to prepare for the future of power distribution.

ComPacT is an integral part of EcoStruxure™ Power – Schneider's open, interoperable, IoT-enabled system architecture. Through this platform, we deliver enhanced value around safety, reliability, efficiency, sustainability, and connectivity for our customers. We leverage technologies in IoT, mobility, sensing, cloud, analytics, and cybersecurity to deliver Innovation at Every Level. This includes Connected Products, Edge Control, and Apps, Analytics & Services. EcoStruxure has been deployed in 450,000+ installations, with the support of 9,000 system integrators, connecting over 1 billion devices.

The launch of Schneider Electric ComPacT NS in 1994 revolutionized the world of molded case circuit breakers and benefits from 60 years of experience and leadership in industrial circuit breakers.

As well as offering proven performance, flexibility and reliability, the ComPacT NS sets the standard in most applications: buildings, windturbine, solar, genset, data center, healthcare, marine and infrastructure and decrease your energy consumption thanks to very low power dissipation.

Equipped with the Micrologic control units, ComPacT NS630b to 3200 A circuit breakers offer built-in power and energy metering in addition to electrical measurement and analysis functions.

The communication option makes it possible to control power consumption, simplify maintenance and improve operating comfort.

A wide range of optimized auxiliaries and accessories is available to meet the needs of protection of AC installations, generator protection, motor protection, switch-disconnectors, source changeover switch function and specific offers available for DC applications up to 1000 V.

Today, the ComPacT NS range remains the international reference in the molded-case, circuit breaker market.



H

I

J

Meet the new face of connected breaker technology

70 years of innovative and reliable protection



The Schneider Electric™ ComPacT™ range is built on 70 years of expertise and leadership in industrial circuit breakers.

Today Schneider Electric is launching its new generation of ComPacT molded case circuit breakers. The comprehensive, optimized ComPacT range covers your protection and has been redesigned with a superior customer experience in mind.

The range combines wireless intelligent metering and monitoring, along with advanced protective functions.

This range can be connected to Schneider Electric's open, interoperable, IoT-enabled EcoStruxure™ Power architecture. Through this platform we deliver enhanced value in terms of safety, reliability, efficiency, sustainability, and connectivity.

We leverage technologies in IoT, mobility, sensing, cloud, analytics, and cybersecurity to deliver Innovation at Every Level. This includes connected products, edge control, apps, analytics and services.



SEE THE VIDEO 

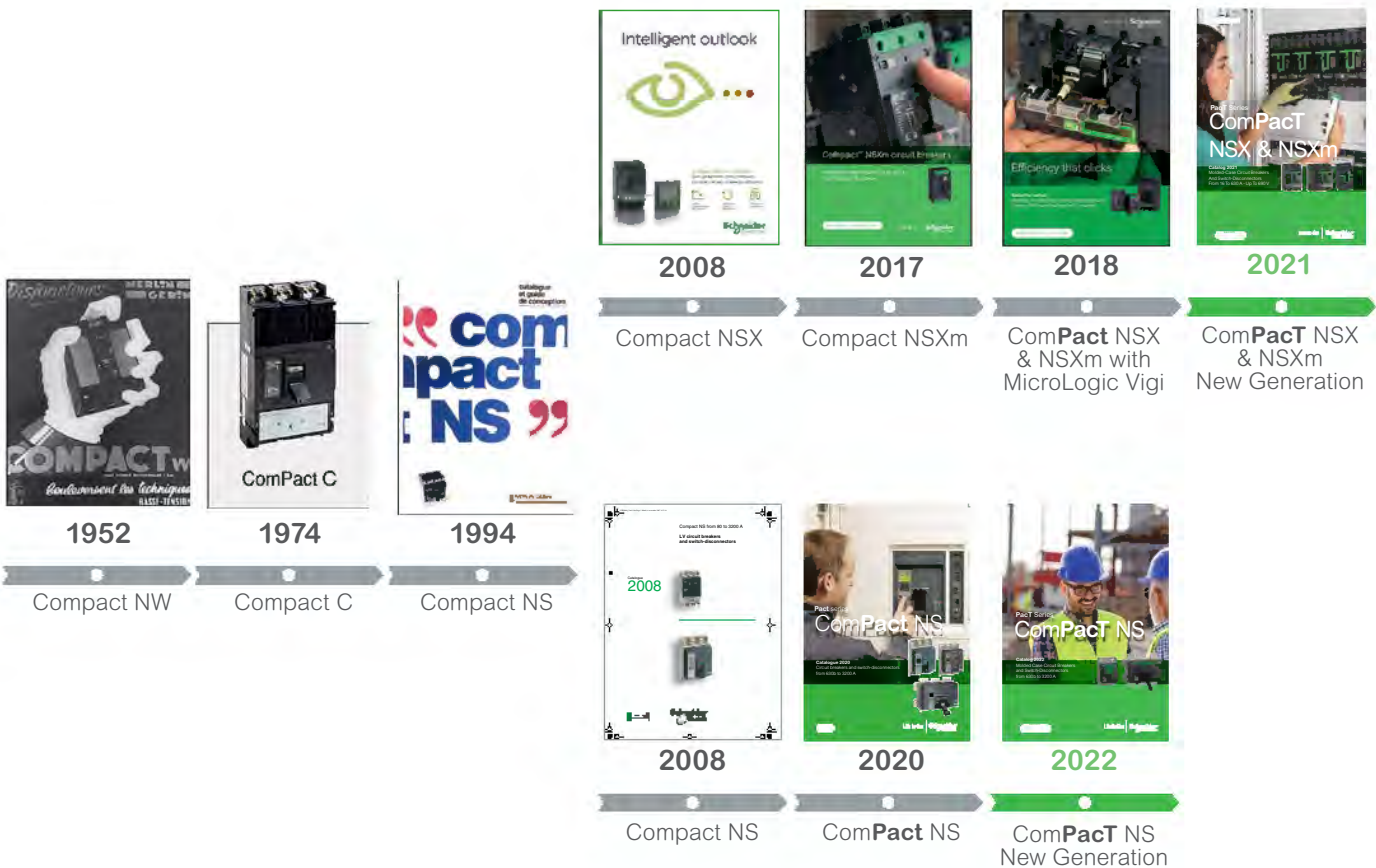

Design electrical solutions

More than 10 years of long-felt techniques and technologies ahead quite simple and convenient.



Win more projects and deliver the best solution for your customers

- Enhance power availability with total control of selectivity and power management with advanced trip unit.
- Optimize panel cost with cascading; the ComPacT NS technology covers all your needs from 630 to 3200 A, with a breaking capacity from 50 to 200 kA.
- Equipped with electronic control units, the ComPacT NS circuit breakers ensure protection and measurement of your electrical installation.
- Provide efficiency to your customer with small size and multi-ways of installation and highly immune protection system insensitive to disturbances (IEC 60947-2 Annex F).

Standards

ComPacT NS circuit breakers and auxiliaries comply with:

- IEC/EN 60947-1: General rules
- IEC/EN 60947-2: Circuit-breakers
- IEC/EN 60947-3: Switch-disconnectors
- IEC/EN 60947-4-1: Contactors and motor-starters
- IEC/EN 60947-5-1: Control circuit devices

The ComPacT NS range covers all ratings from 630 to 3200 A

ComPacT NS630b to 1600

- ComPacT NS from 630 to 1600 A, fixed or withdrawable, front or rear connection, manual operating mechanism or motor mechanism. A 200 kA breaking performance completes the ComPacT NS range

ComPacT NS1600b to 3200

- ComPacT NS from 1600 to 3200 A, fixed, front connection, with manual operating mechanism

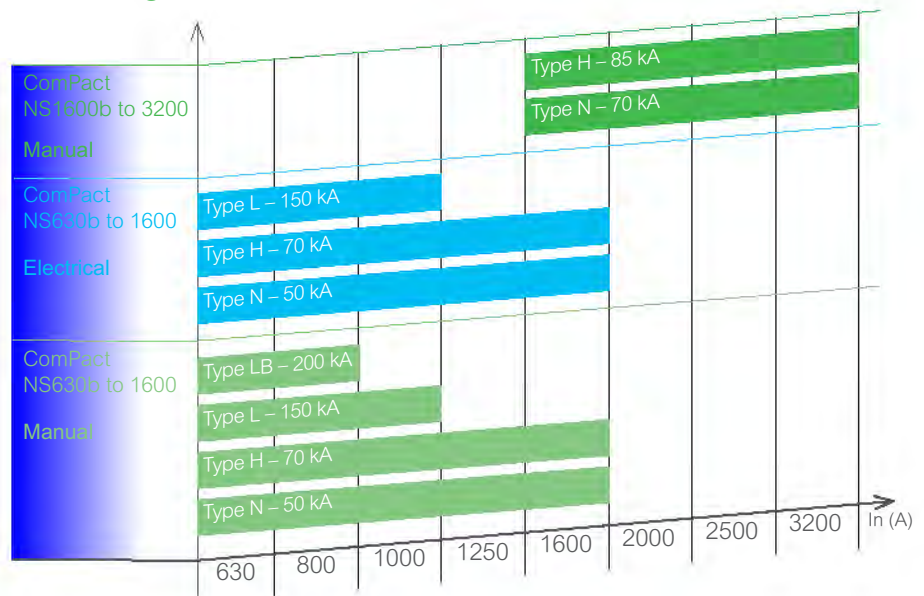

The MasterPact and ComPact range Circuit breakers, switch-disconnectors and source changeover are the best choice for all standards and specific applications.

Build and install electrical equipment



Make your business more profitable

Gain space in your switchboard

- The ComPacT NS range is available in 2 sizes only in order to homogenize installation dimensions (volume, depth, pole pitch).
- Easy to select and to order with new Schneider Electric™ online tools.

Gain time, the installation is facilitated

- More space to connect your cables.
- Withdrawable version also available.



A

B

C

D

E

F

G

H

I

J

Design and build machines

A

B

C

D

E

F

G

H

I

J

Installation

Fixed device

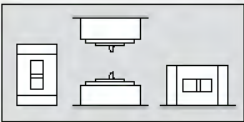

Withdrawable device

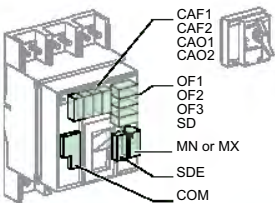
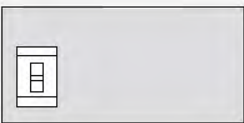

Manually operated device.

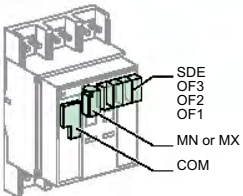

Electrically operated device.

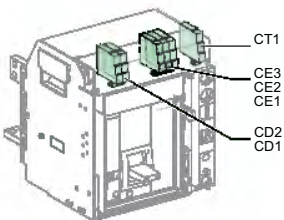

Withdrawable device.

Optimize your solution

- **Minimum distances** (safety clearance) between 2 circuit breakers are reduced thanks to the arc chute filters.
- **A solution for all your applications:**
 - generator protection
 - motor protection up to 750 kW with coordination between breakers and contactors (coordination type 1 and type 2)
 - source-changeover.
- **Best combination** of size (small depth), performance with no derating up to 65 °C (vertical connection) and flexible mounting options.
- **Ensure continuity of service:**
 - Total control of selectivity for the whole Schneider Electric circuit breakers range from moulded circuit breaker to air circuit breaker
 - High withstand of the devices to various environmental stresses.
- **Bring flexibility to your installation:**
Interchangeable trip units, standardized accessories, adjustable rating and scalable indication and control functions.



Operate my installation

I operate and manage my installation

Ensure continuity of service

- Electrical energy is available, prevent nuisance power outages using total control of selectivity.

Monitor your power

- Power consumption is optimized with on-site, real-time monitoring and control, plus online energy management services
- Maintenance is simplified
- Installation is scalable
- Using ComPacT NS will decrease permanent consumption with lower power dissipations.

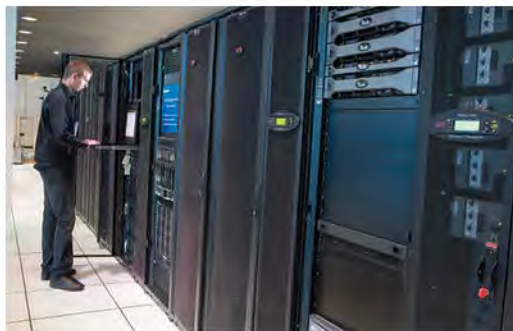

General overview

ComPacT NS

Schneider Electric is proud to introduce the new generation of ComPacT MCCBs. These breakers talk to you, wherever you are, in all transparency.

New design complements new wireless connectivity capabilities with our latest wireless indication auxiliary.

ComPacT Design



New signature design

- Schneider Electric green signature style for the entire ComPacT range
- Estimated 40% reduction of wiring time for panel builders
- Experience easier installation thanks to a new ergonomic front-plate design
- Gain the confidence that all auxiliaries are on the right spot, and simply double check that you have the right coil rating
- Ergonomic new toggle for easier breaker manual operation

Wireless indication auxiliary



Wireless breaker status

- Plug & play technology for clear connection status (0 or 1, no half-way wired)
- Placed in the same position as the wired version, its LED light will give you direct indication in case of a tripping
- If you are away, your ComPacT will send you an immediate notification via EcoStruxure Facility Expert for instance
- Wireless auxiliary accelerates overall wiring time: status communication is done very simply and commissioned wirelessly
- Communication architecture is fully EcoStruxure Power validated, with any application

Contribute to a better world. Enhance sustainability with ComPacT range

Achieve Green Building certification with Green Premium ecolabel

In compliance with ISO 14025 PEP ecopassport program, we publish a comprehensive Life Cycle Analysis of our product, providing the environmental data you need to achieve Green Building certifications.

For example, ComPacT NS contribute to 3 LEED™ points in the Building Product Disclosure and Optimization section:

- Environmental Product Declaration
- Material Ingredients

ComPacT range is now enriched with the new ComPacT NS, designed according to the EcoDesign Way™ by Schneider. It now features new space saving frame size for reduced resource consumption, and more.

ComPacT NS new generation

Learn about more ComPacT NS range here

Offer

Catalogue

Scan or click on QR code

If you need more details about product references and availability, please check your local Schneider Electric contact <https://www.se.com/ww/en/work/support/country-selector/contact-us.jsp>



ComPacT NSX & NSXm

A

B

C

D

E

F

G

H

I

J



Meet the new face of connected breaker technology

70 years of innovative and reliable protection

The Schneider Electric™ ComPacT™ range is built on 70 years of expertise and leadership in industrial circuit breakers.

Today Schneider Electric is launching its new generation of ComPacT molded case circuit breakers.

The comprehensive, optimized ComPacT range covers your protection and has been redesigned with a superior customer experience in mind.

The range combines wireless intelligent metering and monitoring, along with advanced protective functions.

This range can be connected to Schneider Electric's open, interoperable, IoT-enabled EcoStruxure™ Power architecture. Through this platform we deliver enhanced value in terms of safety, reliability, efficiency, sustainability, and connectivity.

We leverage technologies in IoT, mobility, sensing, cloud, analytics, and cybersecurity to deliver Innovation at Every Level. This includes connected products, edge control, apps, analytics and services.



SEE THE VIDEO



ComPacT NSX and NSXm, even more innovative and efficient

ComPacT circuit breakers feature Schneider Electric's exclusive Roto-Active Breaking System; it reduces the effects of short circuits of your installation.

Today, the ComPacT range is optimized with a high level of breaking capacities, outstanding selectivity and cascading. It offers more advanced functions and ergonomic designs for easy installation and operations.

Eleven performance levels

K | HB2 | HB1 | R | L | S | H | N | F | B | E

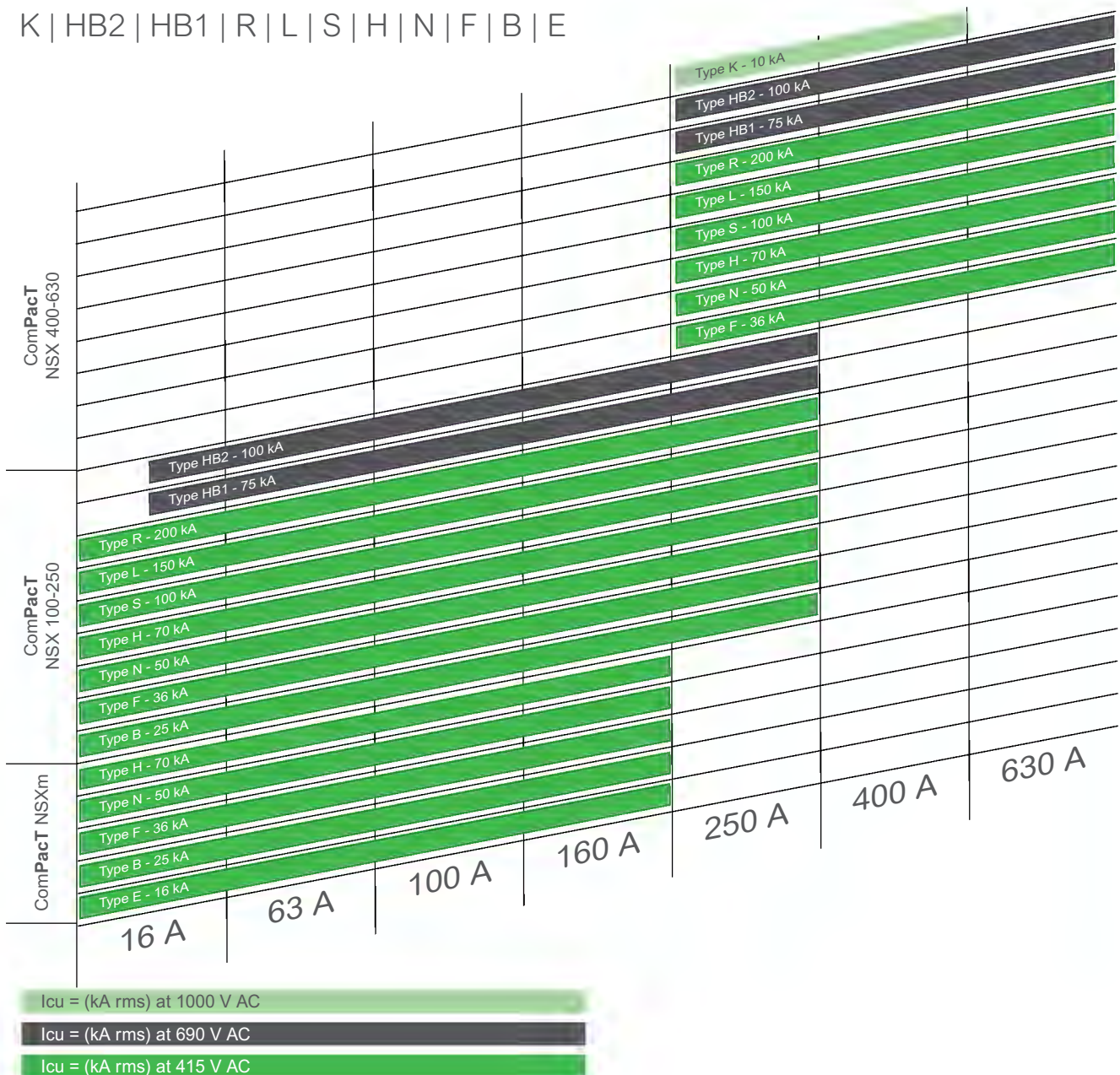

ComPacT NSX & NSXm

Schneider Electric is proud to introduce the new generation of ComPacT MCCBs. These breakers talk to you, wherever you are, in all transparency. New design complements new wireless connectivity capabilities with our latest wireless auxiliary contact.

New

ComPacT Design



New signature design

- Plug & play technology for clear connection status (0 or 1, no half-way wired)
- Placed in the same position as the wired version, its LED light will give you direct indication in case of a tripping
- If you are away, your ComPacT will send you an immediate notification via EcoStruxure Facility Expert for instance
- Wireless auxiliary accelerates overall wiring time: status communication is done very simply and commissioned wirelessly
- Communication architecture is fully EcoStruxure Power validated, with any application
- Schneider Electric green signature style for the entire ComPacT range
- Estimated 40% reduction of wiring time for panel builders
- Experience easier installation thanks to a new ergonomic front-plate design
- Gain the confidence that all auxiliaries are on the right spot, and simply double check that you have the right coil rating
- Ergonomic new toggle for easier breaker manual operation

New

Wireless Auxiliary Contact



Wireless breaker status

- Plug & play technology for clear connection status (0 or 1, no half-way wired)
- Placed in the same position as the wired version, its LED light will give you direct indication in case of a tripping
- If you are away, your ComPacT will send you an immediate notification via EcoStruxure Facility Expert for instance
- Wireless auxiliary accelerates overall wiring time: status communication is done very simply and commissioned wirelessly
- Communication architecture is fully EcoStruxure Power validated, with any application

While we are launching a new generation of ComPacT breakers, we are building upon the very latest innovations that made the success of the range in the first place. The following innovations were launched recently and are still very much applicable to the new generation of ComPacT breakers.

New

ComPacT NSXm



Smallest size in the range

- Schneider Electric green signature style for the entire ComPacT range
- Estimated 40% reduction of wiring time for panel builders
- Experience easier installation thanks to a new ergonomic front-plate design
- Gain the confidence that all auxiliaries are on the right spot, and simply double check that you have the right coil rating
- Ergonomic new toggle for easier breaker manual operation
- ComPacT NSXm is the smallest frame size in the range, incorporating new features and innovations
- Gain up to 40% in space when using with integrated earth leakage protection
- Reduce up to 40% mounting and cabling time with EverLink™ connectors, built-in DIN rail and spring-type auxiliaries
- Select, configure and commission with ease, thanks to Schneider Electric online tools: EcoStruxure Customer Lifecycle Software, such as EcoStruxure Power Design – Ecodial

New

MicroLogic Vigi



Integrated earth leakage protection

- Plug & play technology for clear connection status (0 or 1, no half-way wired)
- Placed in the same position as the wired version, its LED light will give you direct indication in case of a tripping
- If you are away, your ComPacT will send you an immediate notification via EcoStruxure Facility Expert for instance
- Wireless auxiliary accelerates overall wiring time: status communication is done very simply and commissioned wirelessly
- Communication architecture is fully EcoStruxure Power validated, with any application
- Easy to integrate into a row that does not have earth leakage protection
- Simple to use, reliable, and now comes in the same frame size, and for the same panel support
- Gain up to 40% in space when using with integrated earth leakage protection into the MicroLogic Vigi trip units
- Standard protection of distribution cables
- Part of the EcoStruxure Power architecture, with digital communication capability and data management (settings, measurement, pre-alarms, trip & test history)

ComPacT NSX & NSXm

- A
- B
- C
- D
- E
- F
- G
- H
- I
- J

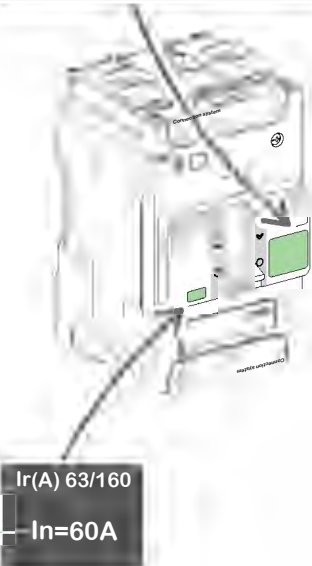

Standardized characteristics indicated on the rating plate:

- A** Type of device: frame size and breaking capacity class
- B** Circuit breaker/switch-disconnector symbol
- C** Commercial reference
- D** Ui: rated insulation voltage
- E** Uimp: rated impulse withstand voltage
- F** Ue: operational voltage
- G** Reference standard
- H** Circuit breaker rating

Note: When the circuit breaker is equipped with an extended rotary handle, the door must be opened to access the rating plate.



Compliance with Standards

ComPacT NSX and NSXm circuit breakers and switch-disconnectors comply with the following:

- International standards
 - IEC 60947-1: general rules
 - IEC 60947-2: circuit breakers
 - IEC 60947-3: switch-disconnectors
 - IEC 60947-4-1: contactors and motor starters ^[1]
 - IEC 60947-5-1 and following: control circuit devices and switching elements; automatic control components
- European standards (EN 60947-1, EN 60947-2, EN 60947-3, EN 60947-4-1 and EN 60947-5-1)
- China CCC
- EAC (Customs Union)
- The specifications of the marine classification companies (Bureau Veritas, Lloyd's Register of Shipping, Det Norske Veritas, etc.), recommendations issued by the CNOMO organization.

Pollution Degree

ComPacT NSX and NSXm circuit breakers and switch-disconnectors are certified for operation in pollution degree 3 environments as defined by IEC standards 60947-1 and 60664-1 (industrial environments).

Climatic Withstand

ComPacT NSX and NSXm circuit breakers have successfully passed the tests defined by the following standards for extreme atmospheric conditions.

Dry cold and dry heat

- IEC 60068-2-1: dry cold at -55°C
- IEC 60068-2-2: dry heat at +85°C.

Damp heat (tropicalization)

- IEC 60068-2-30: damp heat (temperature + 55°C and relative humidity of 95%)
- IEC 60068-2-52: severity 2 - Cycling salt mist.

Environment

ComPacT NSX and NSXm respects the European environment directive 2011/65/EU (amendment 2015/863/EU) concerning the restriction of hazardous substances (RoHS) and is Green Premium.

Product environment profiles (PEP) have been prepared, describing the environmental impact of every product throughout its life cycle, from production to the end of its service life.

All ComPacT production sites have set up an environmental management system certified ISO 14001.

Each factory monitors the impact of its production processes. Every effort is made to prevent pollution and to reduce consumption of natural resources.

Ambient Temperature

- ComPacT NSX and NSXm circuit breakers may be used between -25°C and +70°C. For temperatures higher than 40°C, (for ComPacT NSX: +65°C for circuit breakers used to protect motor feeders) devices must be derated
- Circuit breakers should be put into service under normal ambient, operating-temperature conditions. Exceptionally, the circuit breaker may be put into service when the ambient temperature is between -35°C and -25°C
- The permissible storage temperature range for ComPacT NSX and NSXm circuit breakers in the original packing is -50°C ^[2] ^[3] and +85°C.

[1] For ComPacT NSX

[2] For ComPacT NSXm: -40°C for ComPacT NSXm MicroLogic Vigi 4.1

[3] For ComPacT NSX: -40°C for Micrologic Vigi 4, MicroLogic 5, MicroLogic 6 and MicroLogic Vigi 7

Electromagnetic Compatibility

ComPacT NSX and NSXm devices are protected against:

- Overvoltages caused by circuit switching (e.g. lighting circuits)
- Overvoltages caused by atmospheric disturbances
- Devices emitting radio waves such as mobile telephones, radios, walkie-talkies, radar, etc.
- Electrostatic discharges produced by users.

Immunity levels for ComPacT NSXm comply with the standards below.

- IEC/EN 60947-2: Low-voltage switchgear and controlgear, part 2: Circuit breakers:
 - Annex F: Immunity tests for circuit breakers with electronic protection
 - Annex B: Immunity tests for residual current protection.
- IEC/EN 61000-4-2: Electrostatic-discharge immunity tests.
- IEC/EN 61000-4-3: Radiated, radio-frequency, electromagnetic-field immunity tests.
- IEC/EN 61000-4-4: Electrical fast transient/burst immunity tests.
- IEC/EN 61000-4-5: Surge immunity tests.
- IEC/EN 61000-4-6: Immunity tests for conducted disturbances induced by radio-frequency fields.
- IEC/EN 61000-4-8: Power frequency magnetic field immunity test.
- IEC/EN 61000-4-11: Voltage dips, short interruptions and voltage variations immunity tests.
- CISPR 11: Industrial, scientific and medical equipment - Radio-frequency disturbance characteristics - Limits and methods of measurement.

Suitable for Isolation with Positive Contact Indication

All ComPacT NSX and NSXm devices are suitable for isolation as defined in IEC standard 60947-2:

- The isolation position corresponds to the O (OFF) position
- The operating handle cannot indicate the OFF position unless the contacts are effectively open
- Padlocks may not be installed unless the contacts are open.

Installation of a rotary handle or a motor mechanism does not alter the reliability of the position-indication system.

The isolation function is certified by testing:

- The mechanical reliability of the position-indication system
- The absence of leakage currents
- Overvoltage withstand capacity between upstream and downstream connections.

The tripped position does not insure isolation with positive contact indication.

Only the OFF position confirms isolation.

Installation in Class II Switchboards

All ComPacT NSX and NSXm devices are class II front face devices. They may be installed through the door of class II switchboards (as per IEC standards 61140 and 60664-1) without downgrading switchboard insulation. Installation requires no special operations, even when the circuit breaker is equipped with a rotary handle or a motor mechanism.

Degree of Protection

The following indications are in accordance with standards IEC 60529 (IP degree of protection) and IEC 62262 (IK protection against external mechanical impacts).

Bare Circuit Breaker with Terminal Shields

- With toggle: IP40, IK07.
- With direct rotary handle: IP40, IK07.

Circuit Breaker Installed in a Switchboard

ComPacT NSXm

- With toggle: IP40, IK07.
- With direct rotary handle: IP40, IK07.
- With extended rotary handle: IP54 or IP65, IK08.
- With side rotary handle: IP54 or IP65, IK08.

ComPacT NSX

- With toggle: IP40, IK07.
- With direct rotary handle:
 - Standard/VDE: IP40, IK07
 - MCC: IP43, IK07
 - CNOMO: IP54, IK08.
- With extended rotary handle: IP55, IK08.
- With motor mechanism: IP40, IK07.



Standardized characteristics indicated on the rating plate:

- A** Type of device: frame size and breaking capacity class
- B** Ui: rated insulation voltage
- C** Uimp: rated impulse withstand voltage
- D** Ics: service breaking capacity
- E** Icu: ultimate breaking capacity for various values of the rated operational voltage Ue
- F** Ue: operational voltage
- G** Circuit breaker/switch-disconnector symbol
- H** Reference standard

Note: When the circuit breaker is equipped with an extended rotary handle, the door must be opened to access the rating plate.

ComPacT NSX & NSXm

A

B

C

D

E

F

G

H

I

J



Learn more about
ComPacT NSX
& NSXm
ranges here



NSX offer



NSXm offer



Catalogue

Scan or
click on
QR code

If you need more details about product references and availability, please check your local Schneider Electric contact
<https://www.se.com/ww/en/work/support/country-selector/contact-us.jsp>

- A
- B**
- C
- D
- E
- F
- G
- H
- I
- J

A

B

C

D

E

F

G

H

I

J



Switch-disconnectors INS/INV40 to 2500 A

Optimize your solution with field-proven & high-performance switch-disconnectors

By adapting to a host of low-voltage applications, the ComPacT INS/INV switch disconnectors range, previously called Interpact, offers the safety users require. This comprehensive and homogeneous range operates with a wide choice of accessories and auxiliaries. Optimize your switchboard ensuring total coordination with MasterPact MTZ, MasterPact NT, MasterPact NW, ComPact NS, ComPact NSX, ComPact NSXm and Acti 9.

Benefits

- Optimize for safety
- Provides disconnection and isolation, even after having undergone short-circuit current
- Efficient installation
- Reduces with shared accessories across the ComPact and MasterPact ranges
- Easy connection to Linergy devices
- Linked to Smart Panels for remote access for information regarding its state

Specifications

- Rated current: 40 to 2500 A (for AC22A, AC23A and DC22A, DC23A utilisation categories)
- High short-circuit for the switch disconnector alone and with upstream protection circuit breaker
- High short-time withstanding current 3 or 4 poles
- IP66 and IP55 local isolation enclosure
- Suitable for isolation with positive contact indication
- Locking by up to three padlocks or lead-sealed in the off position

High performances

No derating for all performances in accordance with IEC60947-3 criteria:

- $I_{th} = I_{the} = I_e$ up to 60°.

Functions and characteristics

Switch-disconnector selection

ComPacT INS40 to 160



ComPacT INS40 to 80 switch-disconnector.

ComPacT INS switch-disconnectors			INS40
Number of poles			3-4
Electrical characteristics as defined by IEC 60947-1 / 60947-3 and EN 60947-1 / 60947-3			
Conventional thermal current (A)	I_{th}	at 60 °C	40
Conventional thermal current in enclosure	I_{the}	at 60 °C	40
Rated insulation level (V)	U_i	AC 50/60 Hz	690
Impulse-withstand voltage (kV)	U_{imp}		8
Rated operational voltage (V)	U_e	AC 50/60 Hz	500
		DC	250
Rated operational voltage AC20 and DC20 (V)		AC 50/60 Hz	690
Rated operational current (A)	I_e	Electrical AC 50/60 Hz	AC22A
		220-240 V	40
		380-415 V	40

Total coordination with MasterPact MTZ, NT, NW, ComPacT NS, ComPacT NSX and ComPacT NSXm

The switch must be chosen according to:

- the characteristics of the network on which it is installed
- the location and the application
- coordination with the upstream protection devices (in particular overload and short-circuit).

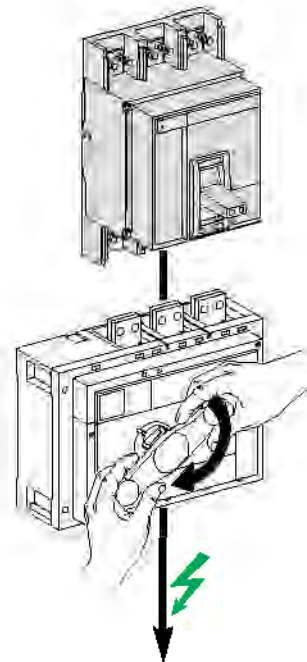

Grow your business with better solutions

Choose the installation that best suits your needs

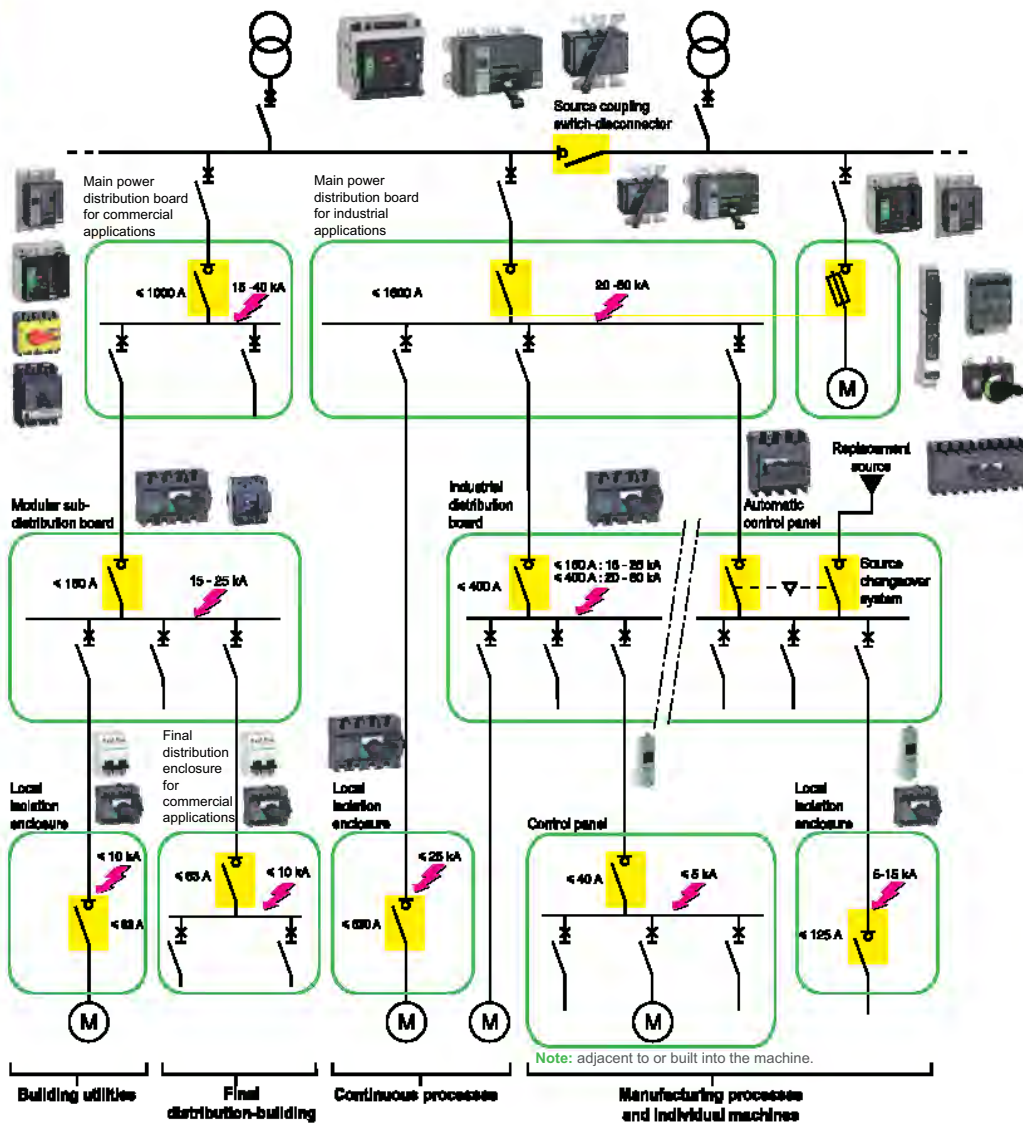

Less stock space needed

- Common accessories for ComPacT INS/INV and ComPacT NSX
- Less product references.

Energy availability thanks to the power-system protection

- Isolation of components under fault.

General overview ComPacT INS & INV

- A
- B**
- C
- D
- E
- F
- G
- H
- I
- J

ComPacT INS & INV

- A
- B
- C
- D
- E
- F
- G
- H
- I
- J



The complete range	40 A	63 A	80 A	100 A	125 A	160 A	200 A	250 A
Modular profile	INS40	INS63	INS80PV	INS100	INS125	INS160		
				INS250-100		INS250-160	INS250-200	INS250
	INSE 40-80							

ComPacT INS

Switch-disconnectors with positive contact indication				
Emergency-off switch-disconnectors with positive contact indication				

Mounting on backplate			INV100	INV160	INV200	INV250
-----------------------	--	--	--------	--------	--------	--------

ComPacT INV

Switch-disconnectors with visible break				
Emergency-off switch-disconnectors with visible break				

Selection guide ComPacT INS & INV

320 A	400 A	500 A	630 A	630b A	800 A	1000 A	1250 A	1600 A	2000 A	2500 A
-------	-------	-------	-------	--------	-------	--------	--------	--------	--------	--------

INS320	INS400	INS500	INS630	INS630b	INS800	INS1000	INS1250	INS1600	INS2000	INS2500
INSJ400										



INV320	INV400	INV500	INV630	INV630b	INV800	INV1000	INV1250	INV1600	INV2000	INV2500
--------	--------	--------	--------	---------	--------	---------	---------	---------	---------	---------



- A
- B
- C
- D
- E
- F
- G
- H
- I
- J



Learn more about
ComPacT INS/INV
ranges here



Offer



Catalogue

Scan or
click on
QR code

If you need more details about product references and availability, please check your local Schneider Electric contact <https://www.se.com/ww/en/work/support/country-selector/contact-us.jsp>

A

B

C

D

E

F

G

H

I

J



Circuit breakers from 100 to 500 A

Meet the new connected face of circuit-breaker technology

Schneider Electric photovoltaic packages give you dependable, clean, and affordable solar power.

High quality, highly efficient, and available everywhere, our systems are simple-to-install, giving you a competitive edge. The ComPacT NSX DC range of molded case circuit breakers with operational voltage up to 1500 V DC includes the switchgears and the protection components you need to efficiently operate your photovoltaic installation in commercial buildings and power plants.





With heatsinks supplied as standard, the circuit breaker or switch-disconnector rating is optimized, avoiding the need to oversize protection components and saving space in the enclosure.

As part of the ComPacT NSX range, all existing auxiliaries and accessories are compatible.

The terminal shields and phase barriers are available for insulation.

The shunt trip auxiliary is available for remote disconnection.

ComPacT NSX DC EP...

...with long heatsinks



ComPacT NSX DC EP from 100 to 500 A at 1100 V DC and 1500 V DC

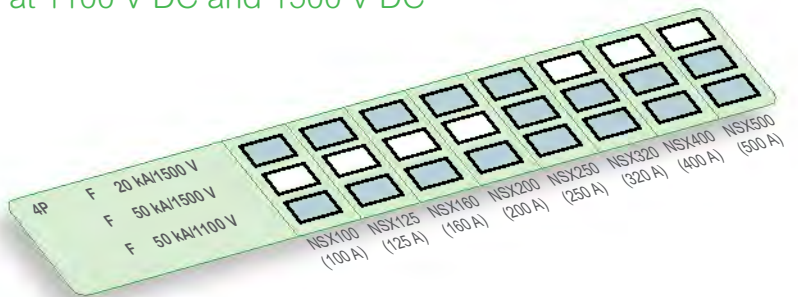

The ComPacT NSX DC EP (Enhanced Performance) range is designed for DC voltages from 1100 to 1500 V and offers:

- Eight current ratings: 100, 125, 160, 200, 250, 320, 400 and 500 A
- Two high breaking-capacity level F:
 - 50 kA for systems ≤1100 V
 - 50 kA for systems ≤1500 V
 - 20 kA for systems ≤1500 V
- Two types of devices:
 - Circuit breaker for the protection of power circuits and loads
 - Switch-disconnector for circuit control and disconnection
- Fixed and withdrawable versions for the entire range
- Integrated protection: Overload/short circuit protection with Thermal magnetic
- Dedicated to specific applications:
 - Photovoltaic application under 1500 V
 - Marine application under 1500 V are also presented in this catalog.



ComPacT NSX250
TM DC EP



ComPacT NSX500
TM DC EP



Learn more about
ComPacT NSX DC EP
range here



Offer



Catalogue

Scan or
click on
QR code

If you need more details about product references and availability, please check your local Schneider Electric contact <https://www.se.com/ww/en/work/support/country-selector/contact-us.jsp>



A

B

C

D

E

F

G

H

I

J



Transfer Switching Equipment

Source-changeover systems

For critical applications in particular

For all others in general

A transfer switching equipment is indispensable for applications that need a continuous supply of electric power (hospitals, airports, banks, government facilities, etc.).

However transfer switching equipment is also suitable for all LV electrical installations exposed to:

- > Nominal voltage loss or dip (when there is high demand for electric power)
- > Unpredictable power quality
- > Frequent power cuts

These factors, and many others, can damage the continuity of service of your electrical installation.

For infrastructure managers, a source-changeover system gives direct economic benefits. It is possible to select your source based on power cost.

In this case, the replacement source is used as an alternative, more economical source.



- > Managing energy efficiently
- > Power Cost
- > Safety

3 ways to switch the load to meet your needs



1 Automatic Source-Changeover System (or ATSE: Automatic Transfer Switching Equipment)

An automatic controller may be added to a remote-operated source-changeover system. It is possible to automatically control source transfer according to programmed (dedicated controllers) or programmable (PLC) operating modes. These solutions ensure optimum energy management.

System

Derived ATSE: Two or three circuit breakers that may have different configurations, linked by an electrical interlocking system. A mechanical interlocking system protects against electrical malfunctions or incorrect manual operations, with an automatic control system (dedicated controllers or PLC).

Non-derived ATSE: Specifically designed ATSE with a specific controller for the system. A mechanical interlocking system is standard for product which protects against electrical malfunctions or incorrect manual operations.

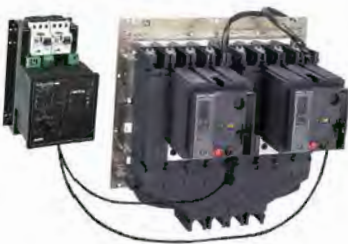

2 Manual Source-Changeover System (or MTSE: Manual Transfer Switching Equipment)

A very simple way to switch the load. It is controlled manually by an operator. The time required to switch from the 'N' source to 'R' source can vary.

System

Two or three mechanically interlocked manually-operated circuit breakers or two switch-disconnectors.



3 Remote-Operated Source-Changeover System (or RTSE: Remote Transfer Switching Equipment)

The most commonly used system for devices with high ratings. No direct human intervention is required. Source-changeover is controlled electrically.

System

Derived RTSE: Two or three circuit breakers that may have different configurations, linked by an electrical interlocking system. In addition, a mechanical interlocking system protects against electrical malfunctions or incorrect manual operations.

Non-Derived RTSE: Specifically TSE that is electrically operated and not self-acting. A mechanical interlocking system is standard for product which protects against electrical malfunctions or incorrect manual operations.



Applications

A

B

C



- **Commercial and service sector** (operating rooms in hospitals, safety systems for buildings, computer rooms for banks and insurance companies, lighting and emergency lighting systems in malls, etc.), **industry and infrastructure.**

D



- Buildings and infrastructure where the need for continuity of service is significant but not a priority: offices, small and medium-sized businesses.

E

F



- **Industry** (assembly lines, engine rooms on ships, critical auxiliaries in thermal powerstations, etc.)
- **Infrastructure** (port and railway installations, runway lighting systems, control systems on military sites, etc.).

H

I

J

Whatever the system,
you benefit from our expertise!

Benefits

For many years Schneider Electric's source changeover system have proved their reliability everywhere around the world, in most power dependable buildings. Switching is performed by ComPacT or MasterPacT circuit breakers, the ultimate references in industrial switchgear.

Maximized continuity of service

- Energy availability is ensured whatever the external requirements (e.g. high power demand)
- Maintenance and replacement of the sources (N or R) can be done with no interruption of service
- You can maintain a continuous level of service and customer satisfaction

Maximized safety

For LV electrical installations where safety and continuity of service are critical for people and/or equipment such as hospitals, airports, banks, malls, etc

Optimized energy management

- Transfer the load to a replacement source according to external requirements
- Manage power sources according to power quality and power costs
- Perform system regulation
- Switch to an emergency replacement source

You are no longer dependent on your power supply (and supplier)!

Simplicity and reliability

- **Simple installation** on LV switchboard
- **Optimized size** of the switchboard
- System **based on pre-tested components**
- Compliance with **IEC 60947-6-1**

A

B

C

D

E

F

G

H

I

J

General overview

TransferPacT

Class PC

Transfer**PacT** is a high speed, com**PacT**, modular design intelligent automatic transfer switch that provides maximum scalability and robust performance. It is a Class PC ATSE designed according to IEC 60947-6-1, available through 32 A to 1600 A, 2, 3, 4 pole with rated operating voltage through 208 V to 440 V^[*].

[*] Voltage varies depending on different frame. For more information, see general feature section.

Power availability

Maximized uptime

Innovative technology ensuring transfer in less than 500 ms.

Vast application

Utilization category AC-33B without derating, fits the most complicated load types.

Reliable under extreme condition

Short circuit capabilities including short time withstand current for your power continuity.

Robust design – Extreme Environment Proof

- Best-in-class electromagnetic protection, exceeding industry standards on class B
- Designed to perform in harsh environments with operating temperature -25...+70°C
- Successfully passed testing in compliance with IEC 60068-2-6 and IEC 60068-2-27.



Efficiency

Easy installation

- Built-in DPS and sensing wire, 30% of commissioning time saving
- Multiple installation adapted. E.g. DIN rail for 32 A ~160 A (TA10, TA16).

Enhanced scalability

10 function modules plug and play, non-disruption upgrading.



Connectivity

Natively connected – Integrated in EcoStruxure™ Power

- 24/7 precise power monitoring on voltage, frequency, voltage unbalance, phase rotation
- Predictive maintenance with hands-on approach and cloud-based monitoring software that synthesizes and analyzes performance and alert data into proactive recommendations. Transfer**PacT** enables wherever-you-go visibility.



Cyber security

Designed according to cyber security standard IEC 62443 at the level of SL1



Sustainability

Green premium ecolabel

- Green Package for full product range
- Saving trees - Scan QR code for full version for technical documents.



Learn more about
TransferPacT
range here



Offer



Catalogue

Scan or
click on
QR code

If you need more details about product references and availability, please check your local Schneider Electric contact <https://www.se.com/ww/en/work/support/country-selector/contact-us.jsp>

- A
- B**
- C
- D
- E
- F
- G
- H
- I
- J

A

B

C

D

E

F

G

H

I

J



LV Air circuit breakers from 630 to 4000 A

The easy choice for reliable performance

The EasyPact MVS is a digital circuit breaker for low-voltage system that protects downstream equipment in case of overload or short circuit. The device is equipped with a health status indicator, as well as NFC wireless connection that makes it possible for the device's status and data to be retrieved easily and efficiently on the smart phone.

EasyPact MVS has been designed to be simple, reliable, and cost-effective, revolutionizing customer experience through the whole lifecycle.



reddot winner 2023

One family and two frame sizes

2 sizes:

MVS Frame 1:
630 to 1600 A



MVS Frame 2:
800 to 4000 A

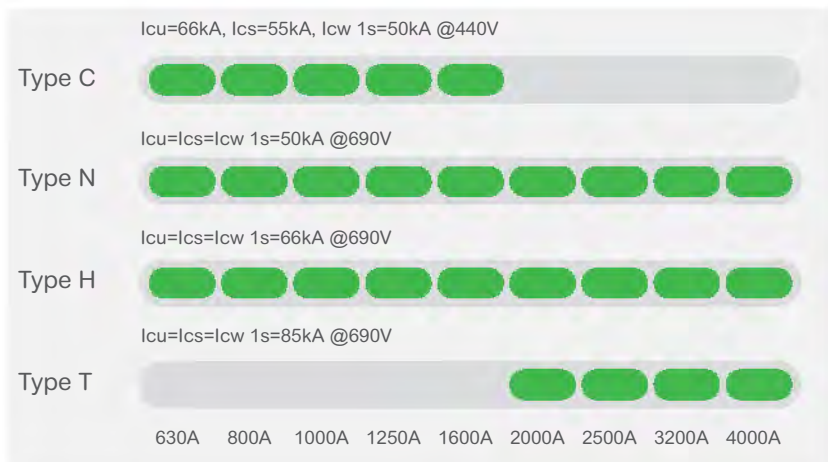

Choose the leader



- 630 to 4000 A ratings
- Breaking capacity: 50 & 65 kA
- Suitable for 690 V applications
- Complete selectivity with I_{cs} 1s up to 85 kA
- Intelligent TS and ET range of trip system with display
- Fully protected neutral on 4 pole breakers
- Full accessories with modular design
- Conforms to IEC 60947- 2 & 3.

Performance Level

- Ratings:
 - Frame 1: 630 to 1600 A,
 - Frame 2: 800 to 4000 A.
- Breaking capacity: 50 & 65 kA.
- Suitable for 690 V applications.
- Complete selectivity with I_{cs} = 100% I_{cu}.
- Circuit breakers type C, N, H.
- Switch-disconnectors type CA, NA, HA.
- 3 or 4 poles.
- Fixed or drawout versions.
- Conforms to IEC 60947- 2 & 3.

Trip system

Type of measurement

- TS for basic protection.
- TSS for "current" on the smart phone.
- ETA for "current".
- ETV for "Energy".

Type of protection

- 2.0 for basic protection.
- 5.0 for selective protection.
- 6.0 for selective + earth-fault protection.



Communication

Eco COM

- EasyPact in a communication network.
- BCM-ULP COM option inside breaker.
- IFM: Modbus interface module.
- I/O application module.

Transmission signal

- Breaker signal: OF, SDE, PF and CH.
- Cradel signal: CD, CT, CE.
- Measurements ways: instantaneous, maximum/minimum, demand.
- Measurements value: current, voltage, power, power factor, energy.
- Protection settings.
- Trip causes.



EasyCom communication

- Independent Modbus interface module.
- Digital Input: 3 sets of OF, SDE, PF.
- Digital output: 3 sets of MX & XF.
- Analog Input: 1 set of 4-20 mA.



M2C programmable contacts

- Two programmable contacts.
- Signal events: I_r, I_{sd}, Alarm I_r, Alarm I_g, I_{gv}.



EasyPact MVS

Benefits for every Customer

EasyPact MVS06 to MVS40

Panel builders / Contractors

- Suitable for copper & Aluminium termination with the pole pitch of 70 or 115 mm
- Terminal orientation can be converted from horizontal to vertical and vice-versa at workshop
- Direct mounting Door frames (escutcheon) without drilling any holes
- Front fitted accessories like under-volt release, shunt release & closing coil for complete range
- Conversion of manual operated breaker in to electrical operated, with single bolt fixing
- With EcoStruxure Power Commission software, you can integrate smart devices, commission connected switchboards, and generate comprehensive reports as part of factory and site acceptance tests.

EasyPact MVS with modular design helps to increase the shop floor efficiency, enabling faster delivery of switchboards.



End users

- Moulded case design ensures high endurance without maintenance
- Intelligent TS range of trip system with thermal memory.
- With a wide range of health indicators, pre-alarm and alarm signal, intuitive support users identify the status.
- Icu=Ics=50 66 & 85kA ensures complete selectivity
- Inbuilt safety shutter & interlocks
- Designed to provide most user safety during installation, during use, and while under maintenance.
- All 4 pole breakers are with fully rated neutral and protected with adjustable settings at OFF – 50%-100%
- With EcoStruxure Power Device software, you can get the operation status and event log by NFC wireless communication method.
- While trip events occurred, trip record helping you to diagnose problems quickly, integrated QR code guides you to the root cause and helps you restore power quickly.

EasyPact MVS answers even to the most stringent application with most reliable distribution systems assuring continuity of service



Designers

- Conforms to IEC60947-2 for breakers & IEC60947-3 for disconnectors
- Designed and manufactured using advanced manufacturing methods to match your quality expectations and the needs of each project.
- Continuous rated coils helps in simple interlocking schemes
- Extensive choice of software tools & documentation to reduce design time.
- EasyPact MVS respects the environment throughout their life cycle
- Wider protection setting to response more industry requirements

EasyPact MVS is designed to meet the needs of your customers with flexibility to achieve system efficiency during the design phase



The Key values

90%

of applications are covered



The performance you need

EasyPact MVS provides the ideal level of capability for your installation from 630 to 4000 A.

30%

Reduce stock by up to



At a cost-effective investment

Pay for what you need: Get outstanding durability with the features you need, with the benefit of easy to order and stock.

100%

Commitment to quality



With the quality you demand

Designed and manufactured by Schneider Electric using advanced manufacturing methods and premium materials.

Easy User Experience

With the **EasyPact MVS** circuit breaker, every stage of the project - from designing and configuring to operating and maintaining - is streamlined using its easy design.

Easy Design



Easy enable and disable protection

- Long time protection
- Instantaneous Protection
- Ground Fault Protection
- Neutral Protection.

Easy adjust protection values

Digital protection setting on EPD



Easy Selection



Product Selector

Configure EasyPact MVS to save time and ensure accuracy.

MySE

Order your EasyPact MVS online.

EcoStruxure Power Commission software

Commission and upgrade easily with protection setting and factory-acceptance test.



Easy Commissioning



EcoStruxure Power Device App

Obtain data visualization and reporting for increased efficiency.

Easy Maintenance and Diagnostic

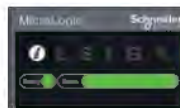

Check healthy status indication on Trip System

Locally in the facility room.



Daily operation with your smartphone

Locally in the facility room.

Easy Upgradation



Firmware upgradation

Let user ease and safe to upgrade the firmware to experience new features.

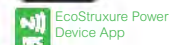

Android

iOS



EasyPact MVS

A



B

C

D

E

F

G

H

I

J



ET21 trip system



ET5S trip system



ET6G trip system

Circuit breakers and switch-disconnectors

- Ratings:
 - **EasyPact MVS** 630 to 4000 A.
 - Circuit breakers type C, N, H.
 - Switch-disconnectors type CA, NA, HA.
 - 3 or 4 poles.
 - Fixed or draw-out versions.

ET trip system

- 2I basic protection.
- 5S selective protection.
- 6G selective + earth-fault protection.
- Standard long-time rating plug:
 - current setting (A) 0.4 to 1 x In.

ETA trip system with current measurement

- 2I basic protection.
- 5S selective protection.
- 6G selective + earth-fault protection.
- Standard long-time rating plug:
 - current setting (A) 0.4 to 1 x In.
 - External power-supply module.

ETV trip system with energy measurement

- 2I basic protection.
- 5S selective protection.
- 6G selective + earth-fault protection.
- Standard long-time rating plug:
 - current setting (A) 0.4 to 1 x In.
 - External power-supply module.

Connections

- Rear connection:
 - horizontal,
 - vertical.
- Optional accessories:
 - interphase barriers,
 - safety shutters and shutter locking blocks.



Safety shutters



Interphase barriers

Locking

- Push button locking by padlockable transparent cover.
- OFF-position locking by keylock.
- Chassis locking in disconnected position by keylock.
- Chassis locking in connected, disconnected and test positions.
- Door interlock (inhibits door opening) with breaker in "connected" or "test" position.

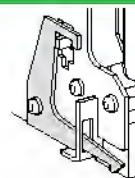

Door interlock

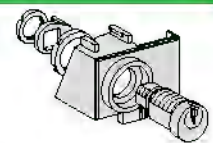

Chassis key lock



Indication contacts

- Standard:
 - ON/OFF indication (OF),
 - "Fault" trip indication (SDE).
- Optional:
 - additional ON/OFF, indication (OF),
 - ready-to-close contact (PF),
 - carriage switches for connected (CE) disconnected (CD) and test (CT) positions.

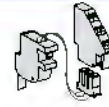

Ready-to-close contact

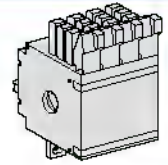

OF contact

Remote operation

- Remote ON/OFF:
 - gear motor,
 - XF closing or MX opening voltage releases.
- Remote tripping function:
 - MN voltage release
 - standard,
 - adjustable or non-adjustable delay.

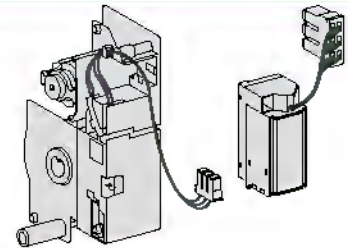

Gear motor

MX, XF and MN voltage releases

Accessories

- Auxiliary terminal shield.
- Operation counter.
- Escutcheon (Door sealing frame).
- Transparent cover for escutcheon.
- Escutcheon blanking plate.

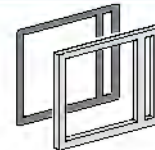

Escutcheon



Transparent cover

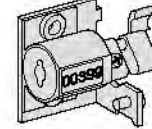

Mechanical operation counter

Source-changeover systems

- Mechanical interlocking using cables:
 - interlocking between two devices,
 - interlocking between three devices.

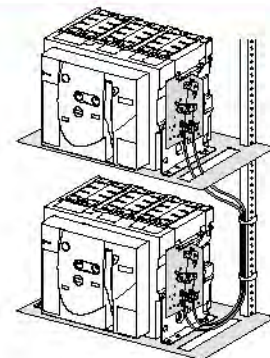

Interlocking of two devices

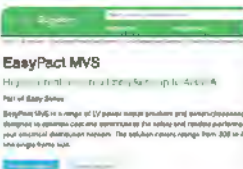

Learn more about
EasyPact MVS
range here



Offer



Catalogue

Scan or
click on
QR code

If you need more details about product references and availability, please check your local Schneider Electric contact <https://www.se.com/ww/en/work/support/country-selector/contact-us.jsp>



EasyPact MVS New Energy

A

B

C

D

E

F

G

H

I

J



Easy Choice For Reliable Performance

One family and One frame size

The EasyPact MVS is a digital circuit breaker for low-voltage system that protects downstream equipment in case of overload or short circuit. The device is equipped with a health status indicator, as well as NFC wireless connection that makes it possible for the device's status and data to be retrieved easily and efficiently on the smart phone.

EasyPact MVS has been designed to be simple, reliable, and cost-effective, revolutionizing customer experience through the whole lifecycle.

EasyPact MVS Type T3 AC Circuit Breaker

- 800 to 4000 A ratings
- Suitable for 1140 V AC applications
- Complete selectivity with $I_{cu} = I_{cs} = I_{cw}$, $1s = 66 \text{ kA}$
- Fixed and drawout versions
- 3 poles
- Conforms to IEC 60947-2

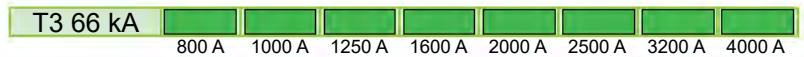

Product Dimension (mm)



Drawout type (H x W x D)



Fixed type (H x W x D)

EasyPact MVS DA1 DC Switch-disconnector

- 1600 to 4000 A ratings
- Suitable for 1500 V DC applications
- Complete selectivity with $I_{cm} = I_{cw}$, $1s = 100 \text{ kA}$
- Fixed version
- 4 poles
- Conforms to IEC 60947-3 (1600-4000 A), UL489B-PV2 (1600-3200 A), UL489 (1600-3200 A)



Product Dimension (mm)



Fixed type (H x W x D)



Rear connection



EasyPact MVS New Energy

New Energy Application

A

B

C

D

E

F

G

H

I

J

LV Side of Transformer
MVS T3 @690/800 V AC
MVS DA1 @1500 V DC

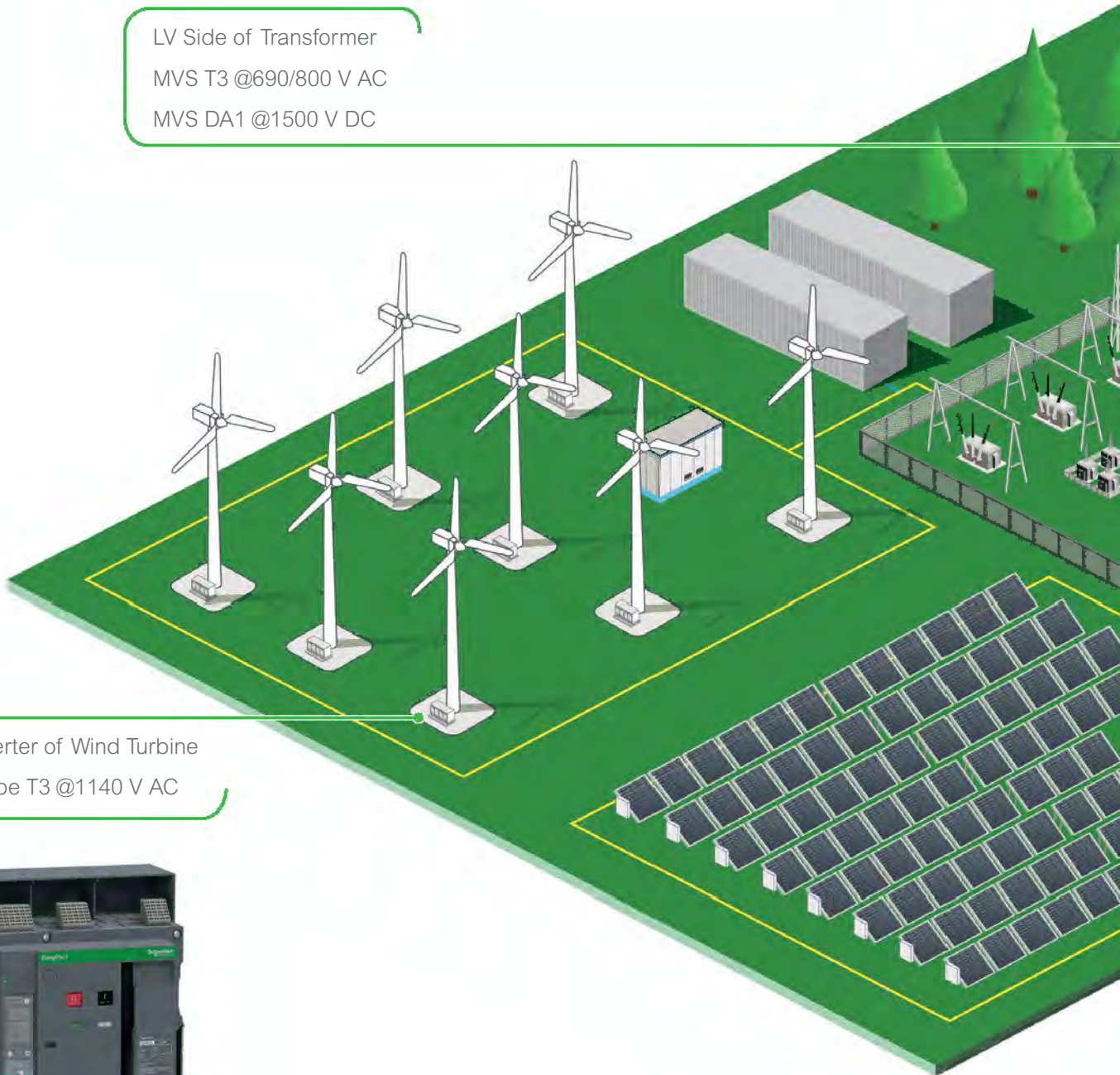

The Inverter of Wind Turbine
MVS Type T3 @1140 V AC



General overview EasyPact MVS New Energy

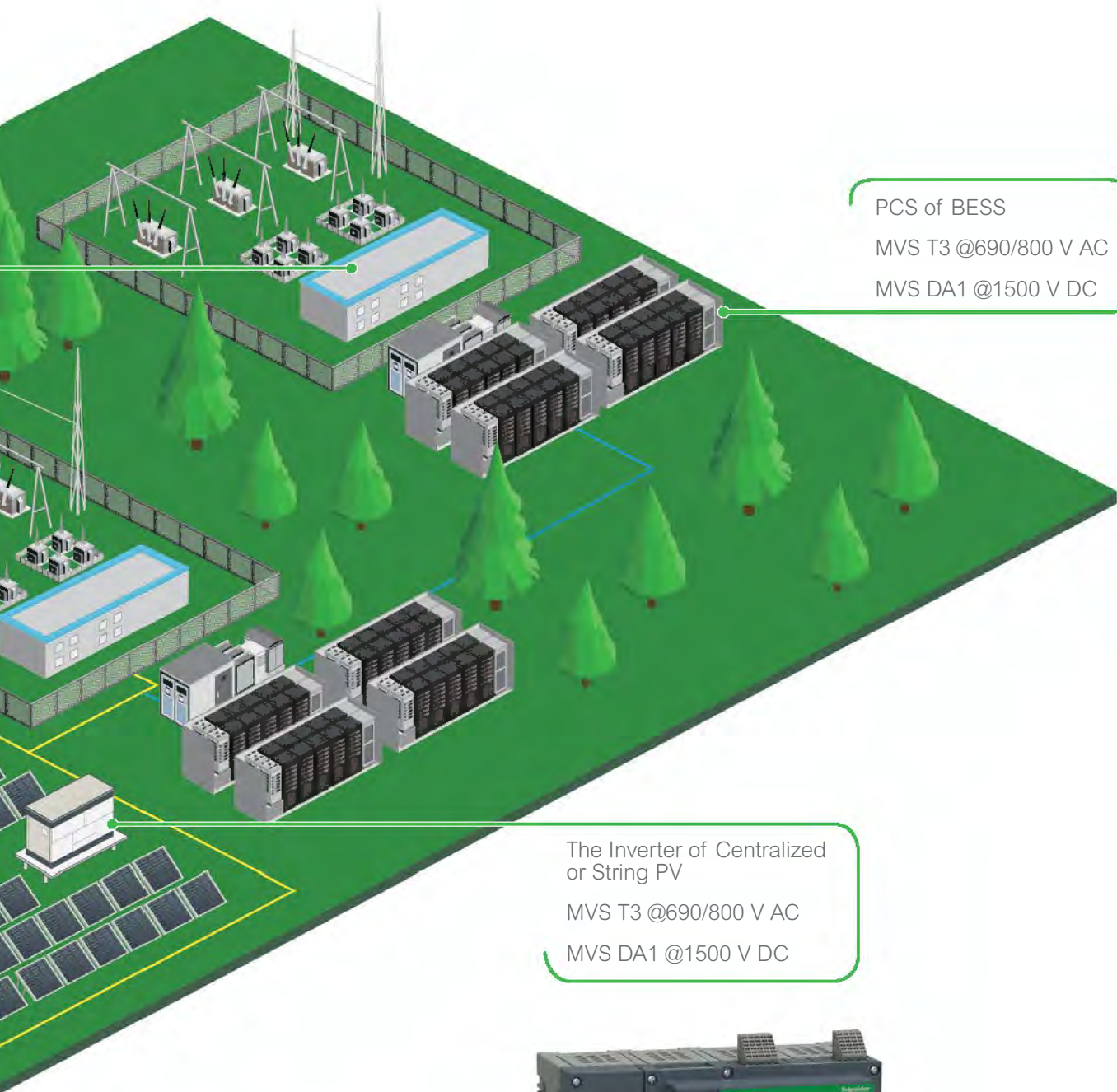

PCS of BESS
MVS T3 @690/800 V AC
MVS DA1 @1500 V DC

The Inverter of Centralized
or String PV
MVS T3 @690/800 V AC
MVS DA1 @1500 V DC



- A
- B**
- C
- D
- E
- F
- G
- H
- I
- J

Gain peace of mind Optimised cost for every installation

A
B
C
D
E
F
G
H
I
J



EasyPact MVS New Energy

General overview

The overview describes all the functions offered by **EasyPact MVS** devices.

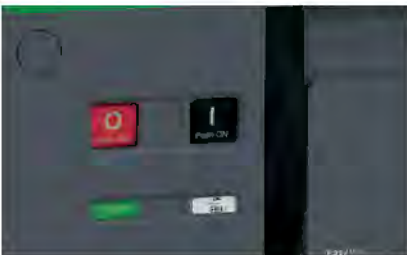

Circuit breakers

- Ratings:
 - **EasyPact MVS** 800 to 4000 A.
- Circuit breakers type: T3.
- 3 poles.
- Fixed or draw-out versions.

ET trip system

- 5S selective protection.
- Standard long-time rating plug:
 - current setting (A) 0.4 to 1 x I_n.

ETA trip system with current measurement

- 6G selective + earth-fault protection.
- Standard long-time rating plug:
 - current setting (A) 0.4 to 1 x I_n.
- External power-supply module.

Switch-disconnectors

- Ratings:
 - **EasyPact MVS** 1600 to 4000 A.
- Switch-disconnectors type: DA1.
- 4 poles.
- Fixed versions.
- Only one frame size.

Indication contacts

- Standard:
 - ON/OFF indication (OF).
- Optional:
 - additional ON/OFF, indication (OF).

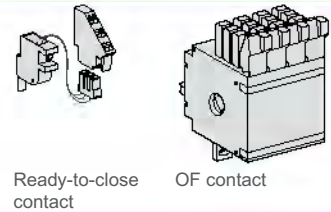

Ready-to-close contact

OF contact

Remote operation

- Remote ON/OFF:
 - gear motor MCH,
 - XF closing or MX opening voltage releases.
- Remote tripping function:
 - MN voltage release
 - standard,
 - adjustable or non-adjustable delay.

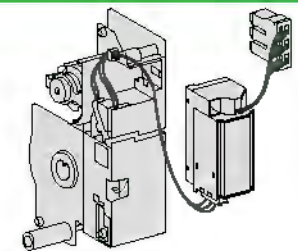

Gear motor

MX, XF and MN voltage releases



EasyPact MVS

High current air circuit breakers up to 4000 A

Part of EasySense

EasyPact MVS is a range of 12 pole air circuit breakers and switch-disconnectors designed to optimize cost and contribute to the safety and reliability of your electrical distribution systems. The standard covers ratings from 800 to 4000 A single frame size.

www.se.com

Learn more about

EasyPact MVS
New Energy
range here



Offer



Catalogue

Scan or click on QR code

If you need more details about product references and availability, please check your local Schneider Electric contact <https://www.se.com/ww/en/work/support/country-selector/contact-us.jsp>



A

B

C

D

E



Easy choice for total Simplicity
So easy, so simple



F

Build your complete solution with Schneider Electric

With just three sizes of circuit breakers, Schneider Electric's **EasyPact™ EZC** system is the simple, universal solution to fit all low-voltage protection needs.

- > The fixed version is particularly adapted to the OEM and Building markets, offering optimum performance at a competitive price.
- > The plug-in version offers an additional function dedicated to the Marine market.

G

H

EasyPact™ EZC range complies with worldwide standards:

- IEC 60947-2
- EN 60947-2
- JISC8201-2-1 / C8201-2-2 (annex 1 and 2)
- GB 14048.2
- UL508 [1]
- CSA22-2 [1]
- IACS for Merchant Marine (International Association of Classification Societies: ABS, BV, CCS, DNV, GL, KRS, LR, NK, RINA).

[1] Only for the 100 A model

With international certifications and approvals by independent laboratories:

- ASEFA, KEMA, TILVA, TÜV, UL.

And compliance with RoHS Directive

- Restriction of Hazardous Substances.



Buildings



Marine



OEM

Easy to choose

EasyPact™ EZC brings you easy solutions

- From 15 A to 630 A
- Up to 50 kA at 415 V
- Up to 4 poles
- In only three frame sizes
- With a complete range of auxiliaries: rotary commands, auxiliaries, shunt trip, phase barrier, terminal cover, undervoltage trip.

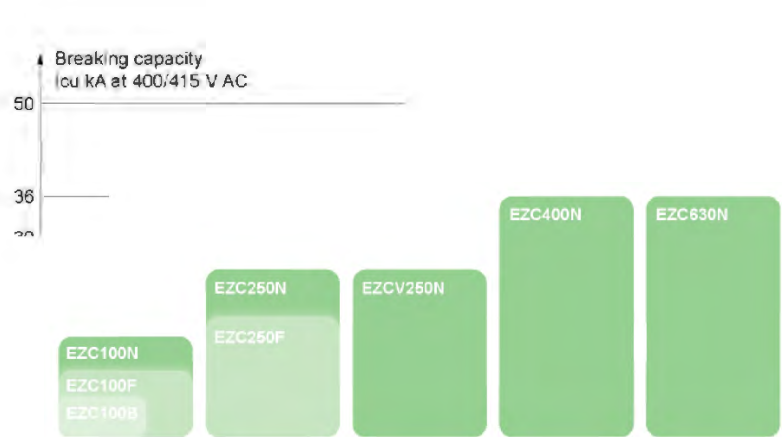

Easy to install

- Fixed front mounting
- Plug-in mounting
- Front connections
- Bare cables connected through cable lugs, screwed inside the breaker
- Field-installable auxiliaries and accessories
- Built-in earth-leakage protection
- Interchangeable MCCB and ELCB.

EasyPact™ EZC 250 ELCB

Built-in Integrated Earth-Leakage Circuit Breaker (ELCB) function

- > Fully interchangeable with MCCB.
- > Same MCCB footprint and panel cut.

Easy to use

- A thermal calibration suitable for MCCB use at 50°C without derating (up to 250 A)
- Positive contact indication for safety and reliability
- A smaller case optimized for tight spaces.

- A
- B**
- C
- D
- E
- F
- G
- H
- I
- J

A



B

Ui	690V		
Uimp	6kV		
Icu	50 kA	18 kA	15 kA
Ics	30 kA	10 kA	8 kA
In	250 A	100 A	63 A
	30 A	15 A	

C

Standardised characteristics indicated on the rating plate:

- Ui: rated insulation voltage
- Uimp: rated impulse withstand voltage
- Ue: rated operational voltage
- Icu: ultimate breaking capacity, for various values of the rated operational voltage Ue
- Ics: service breaking capacity
- In: rated current
- |— suitability for isolation

D

E

F

G

H

I

J



EasyPact EZC circuit breakers and auxiliaries comply with the following international standards:

- IEC 60947-1 - general rules
- IEC 60947-2 - low-voltage switchgear and controlgear, part 2 (circuit breakers)
- European (EN 60947-1 and EN 60947-2) and the corresponding national standards
- GB 14048.2
- JIS C8201-2-1 Annex 1 and Annex 2, for moulded case circuit breakers
- JIS C8201-2-2 Annex 1 and Annex 2, for earth-leakage circuit breakers
- UL 60947-4-1(old UL508)/CSA 22-2 no. 14.

Approvals and Certifications

- IEC certification by independent laboratories (ASEFA, KEMA, TÜV).
- CE marking.
- CCC certified by third-party Tilva.
- UL 60947-4-1(old UL508) certified by third party Underwriter Laboratories as a “Manual Motor Controller” (EVC100/EVC250/EZCV250).

Vibration and shock withstand test

EasyPact EZC circuit breakers resist mechanical vibrations and shocks.

Tests are carried out in compliance with standard IEC 60068-2-6 for the levels required by merchant-marine inspection organisation IACS: International Association of Classification Societies up to 250 A (ABS, BV, DNV, LR, KRS, RINA, NK):

- 2 to 13.2 Hz: amplitude ± 1 mm
- 13.2 to 100 Hz: acceleration 0.7 g.

Pollution degree

EasyPact EZC circuit breakers are certified for operation in pollution-degree III environments as defined by IEC standard 60947 (industrial environments).

Tropicalization

EasyPact EZC circuit breakers have successfully passed the tests prescribed by the following standards for extreme atmospheric conditions:

- IEC 60068-2-1 - dry cold (-55°C)
- IEC 60068-2-2 - dry heat (+85°C)
- IEC 60068-2-30 - damp heat (95% relative humidity at 55°C)
- IEC 60068-2-52 - salt mist (severity level 2).

Positive contact indication

All EasyPact EZC circuit breakers are suitable for isolation as defined in IEC standard 60947-2:

- the isolation position corresponds to the O (OFF) position
- the operating handle cannot indicate the O (OFF) position (“green colour” visible) unless the contacts are effectively open
- padlocks may not be installed unless the contacts are open
- installation of a rotary handle does not alter the reliability of the position-indication system.

The isolation function is certified by tests guaranteeing:

- the mechanical reliability of the position indication system
- the absence of leakage currents
- overvoltage withstand capacity between upstream and downstream connections.

EasyPact EZC circuit breakers take into account important concerns for environmental protection. Most components are recyclable and the parts are marked as specified in applicable standards.

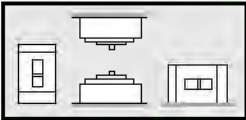

Installation positions.

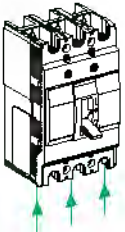

Reverse feeding.

Ambient temperature

- **EasyPact EZC** circuit breakers have been particularly designed to hold 100% In at 50°C without tripping in normal condition (up to 250 A, except earth leakage circuit breakers).
- **EasyPact EZC** circuit breakers may be used between -25°C and +70°C.
- The permissible storage-temperature range for **EasyPact EZC** circuit breakers in the original packing is -35°C to +85°C.

Installation

EasyPact EZC circuit breakers are designed for easy installation in the various types of switchboards. They may be mounted vertically, horizontally or flat on their back without any derating of characteristics.

Power supply

EasyPact EZC circuit breaker can be supplied from either the top or the bottom (reverse feeding) without any reduction in performance. For earth-leakage circuit breakers, reverse feeding is possible only up to 240 V AC. This capability facilitates connection when installed in a switchboard.

Degree of protection

As per standards IEC 60529 (IP degree of protection) and EN 50102 (IK degree of protection against external mechanical impacts).

Bare circuit breaker with terminal shields

	With toggle	IP20	IK07
	With direct rotary handle standard	IP40	IK07

Circuit breaker installed in a switchboard

	With toggle	IP40	IK07
	With direct rotary handle standard/VDE MCC	IP54	IK07
	With extended rotary handle	IP54	IK08

Earth-leakage protection

EasyPact EZC circuit breakers have a specific version including earth-leakage protection. This protection is fully integrated inside the breaker and does not require any additional space.

EasyPact EZC circuit breakers and earth leakage circuit breakers are fully interchangeable.



A

B

C

D

E

F

G

H

I

J



Learn more about
EasyPact EZC
range here



Offer



Catalogue

Scan or
click on
QR code

If you need more details about product references and availability, please check your local Schneider Electric contact
<https://www.se.com/ww/en/work/support/country-selector/contact-us.jsp>

- A
- B**
- C
- D
- E
- F
- G
- H
- I
- J

A

B

C

D

E

F

G

H

I

J



Molded-case circuit breakers and switch-disconnectors from 800 to 1600 A

Easy choice for Quality and Value:
Safe, reliable and simple

EasyPact CVS is designed to meet the requirements of the majority of common protection applications in small to medium-sized buildings, and delivers a high level of performance and cost-saving functionality.

It's Double break mechanism ensures high fault current limitation.

- > Reduces thermal stresses on the electrical distribution network
- > Increases the life of cables and installation.

EasyPact CVS is...Safe



Isolation

- **EasyPact CVS** circuit breakers are suitable for isolation as defined in IEC standards 60947-2. The aim of isolation is to separate a circuit or apparatus from the remainder of a system which is energized in order that personnel may carry out work on the isolated part in perfect safety.
- MCCB locking with external padlocks enables a user to isolate and undertake maintenance with utmost safety.

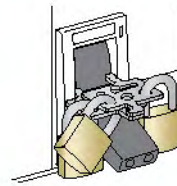

Class II front Face

- All **EasyPact CVS** MCCBs are class II front face devices. They may be installed through the door of class II switchboards without downgrading the switchboard insulation. Installation requires no special operation, even when the circuit breaker is equipped with a rotary handle..

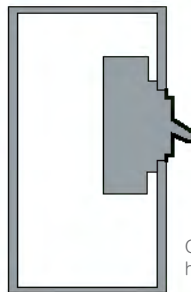

Class II panel with circuit breaker having a class II front face

Locking in OFF position

- Key locks enable to lock the breaker in OFF position ensuring safety and better control on installation
- It also helps in interlocking multiple circuit breakers in an installation.



A

EasyPacT CVS is...Reliable



Conforms to IEC 60947-2 for circuit breaker

- Tested at renown international laboratories like KEMA
- Complete range with Ics = 100% Icu.



Reliable accessories

- Continuous rated shunt coils
- Multifunctional Aux./Alarm contact
- Unique electrical fault trip indication (SDE).

B



High electrical & Mechanical endurance

- 50000 mechanical operations for 800 to 1600 A
- 3000 electrical operations for 800 to 1600 A.

C

D

EasyPacT CVS is...Simple

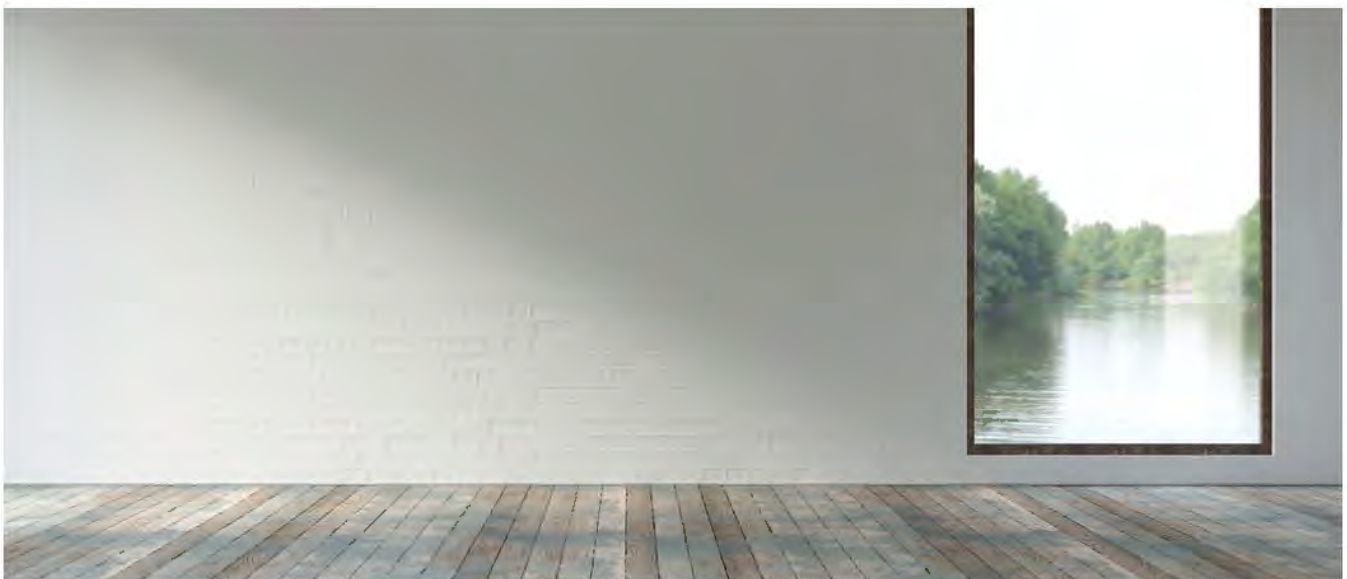

E

F

G

H

800 to 1600 A

- Common and snap-fit accessories 800 to 1600 A
- Multiple OFF contacts for ON/OFF, Trip indication
- Single Shunt coil for remote tripping
- Single Under Voltage coil.

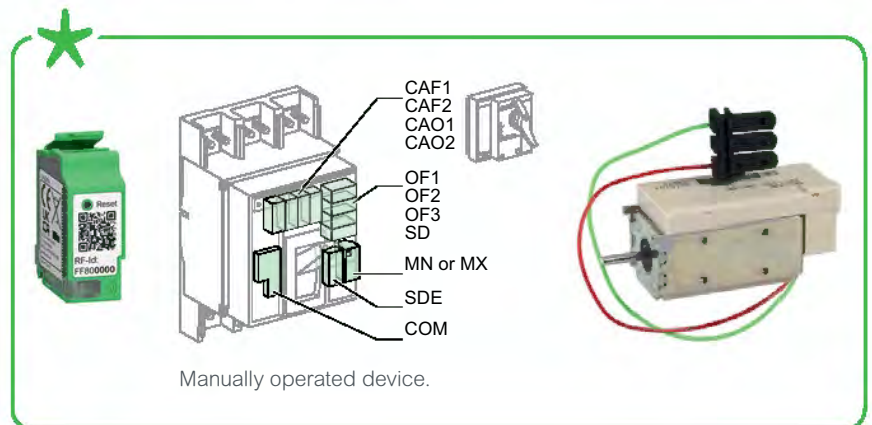

I

J

EasyPacT CVS Stands for Customer Value



Panel builders

- Single frame sizes from 800 to 1600 A
- Common accessories for complete range (ON/OFF/Trip Auxiliaries/Shunt/UV etc.)
- Line load reversibility for entire range
- Suitable for class II switchboards.



End users

- Isolation as a standard feature enhances safety
- Excellent current limiting capability reduces stresses on cables, busbars and loads
- Continuous rated accessories increase system reliability
- Modular earth leakage protection ensure human/installation protection.



OEMs

- High endurance and maintenance-free operation assure continuous performance of machines
- Unique common accessories help standardisation of components.

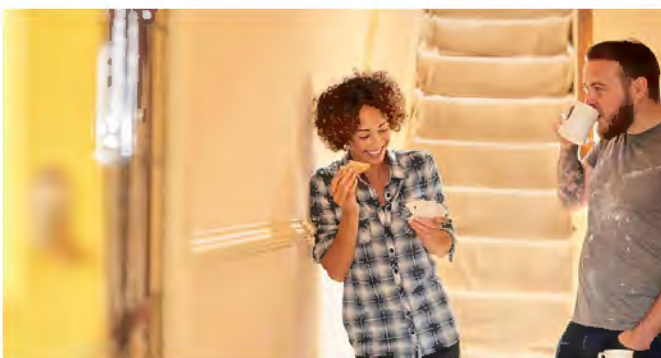

Contractors

- Sufficient pole pitch helps to terminate Copper and Aluminum busbars or cables
- Easy availability of the product due to a small number of frame size
- Designed to perform in demanding applications.

Gain peace of mind, quality, and value for your installations



A
B
C
D
E
F
G
H
J

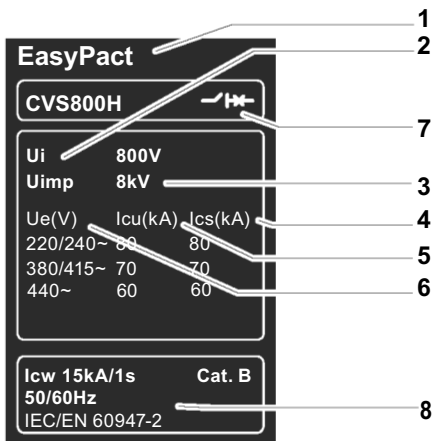

Standardised characteristics indicated on the rating plate:

1. Type of device: frame size and breaking capacity class
2. Ui: rated insulation voltage.
3. Uimp: rated impulse withstand voltage.
4. Ics: service breaking capacity.
5. Icu: ultimate breaking capacity for various values of the rated operational voltage Ue
6. Ue: operational voltage.
7. Suitable for Isolation symbol.
8. Reference standard.

Note: when the circuit breaker is equipped with an extended rotary handle, the door must be opened to access the rating plate.

Compliance with Standards

EasyPact CVS circuit breakers and auxiliaries comply with the following international recommendations:

- IEC 60947-1: general rules
- IEC 60947-2: circuit breakers
- IEC 60947-3: switch-disconnectors

Pollution Degree

EasyPact CVS circuit breakers are certified for operation in pollution-degree III environments as defined by IEC standards 60947-1 and 60664-1 (industrial environments).

Climatic Withstand

EasyPact CVS circuit breakers have successfully passed the tests defined by the following standards for extreme atmospheric conditions:

- IEC 60068-2-1: dry cold (-55°C)
- IEC 60068-2-2: dry heat (+85°C)
- IEC 60068-2-30: damp heat (95 % relative humidity at 55°C)
- IEC 60068-2-52 severity level 2: salt mist.

Environment

EasyPact CVS respects the European environment directive EC/2002/95 concerning the restriction of hazardous substances (RoHS).

All EasyPact CVS production sites have set up an ISO 14001 certified environmental management system.

Ambient Temperature

- EasyPact CVS circuit breakers can be used between -25°C and +70°C. For temperatures higher than 40°C (65°C for circuit breakers used to protect motor feeders), devices must be derated (see page B-2).
- Circuit breakers should be put into service under normal ambient, operating-temperature conditions. Exceptionally, the circuit breaker can be put into service when the ambient temperature is between -35°C and -25°C.
- The permissible storage-temperature range for EasyPact CVS circuit breakers in the original packing is -50°C and +85°C.

- A
- B
- C
- D
- E
- F
- G
- H
- I
- J

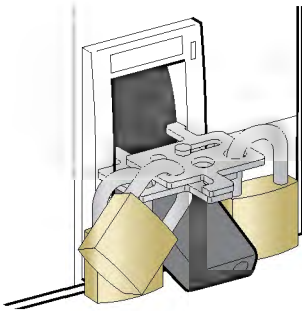

Positive Contact Indication

All EasyPact circuit breakers are suitable for isolation as defined in IEC standard 60947-2:

- The isolation position corresponds to the O (OFF) position.
- The operating handle cannot indicate the OFF position unless the contacts are effectively open.
- Padlocks may not be installed unless the contacts are open.

Installation of a rotary handle does not alter the reliability of the position-indication system.

The isolation function is certified by tests guaranteeing:

- Mechanical reliability of the position indication system.
- Overvoltage withstand capacity between upstream and downstream connections.



Installation in Class II Switchboards

All EasyPact circuit breakers are class II front face devices. They may be installed through the door of class II switchboards (as per IEC standard 60664), without downgrading switchboard insulation. Installation requires no special operations, even when the circuit breaker is equipped with a rotary handle.

Degree of Protection

As per standards IEC 60529 (IP degree of protection) and EN 50102 (IK degree of protection against external mechanical impacts).

Bare Circuit Breaker with Terminal Shields

	With toggle	IP40	IK07
	With direct rotary handle standard / VDE	IP40	IK07

Circuit Breaker Installed in a Switchboard

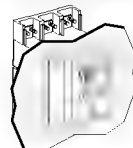
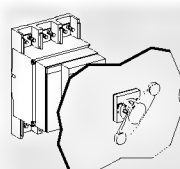
	With toggle	IP40	IK07
	With direct rotary handle Standard / VDE MCC	IP40	IK07
	CNOMO	IP54	IK07
	With extended rotary handle	IP55	IK08



EasyPact CVS
Molded-case circuit breakers from 16 to 630 A, w adjustable settings.
Part of Easy Series
Molded-case circuit breakers (MCCB) with adjustable settings, used from ideal for applications as small to medium-sized buildings.

Learn more about **EasyPact CVS** range here

Offer   Scan or click on QR code

Offer Catalogue

If you need more details about product references and availability, please check your local Schneider Electric contact <https://www.se.com/ww/en/work/support/country-selector/contact-us.jsp>

EasyPact Solar MCCB

A

B

C

D

E

F

G

H

I

J



Molded-Case Circuit Breaker from 125 to 800 A

Fundamentals of protection...

EasyPact Solar MCCB is a specially designed molded case circuit breaker range dedicated to large and medium scale solar farm installations compatible to work with different inverter configurations. High performance, Easy to install / maintain at affordable prices is the hallmark of the offer.

High Reliability at Affordable Prices

As a Schneider Electric offer, the complete range provides:



Customer values



Panel Builders

- Complete range from 125 to 800 A consists of two uniquely sized MCCBs
- Complete portfolio of accessories: electrical auxiliaries, insulation auxiliaries, connection accessories, control accessories, internal accessories
- Built-in trip unit



Contractors

- Sufficient pole pitch helps to terminate copper busbars or cables
- Simple product selection thanks to the support of digital tools



OEM

- Seamless performance in renewable energy power plants
- Meets IEC 60947-2 standard and common technical requirements
- Optimizes space with rating adjusted footprints



End User

- Schneider Electric performance, quality, and warranty
- Simplified catalog of circuit breaker and accessories
- Worldwide availability and optimized lead time

A

B

C

D

E

F

G

H

I

J

Competitive edge with
reliable quality and wide range
of current ratings!



EasyPact Solar MCCB is a simplified offer range with robust quality. Our products maintain performance in harsh environments.



+ Timely delivery, wherever you are

Schneider Electric offers a world-renowned logistics network capable of delivering **EasyPact Solar MCCB** products to you fast, wherever you are.

EasyPact Solar MCCB offers

Enhanced features

- Current ratings ranges from 125 A to 800 A
- Thermal magnetic trip unit from 160 A to 400 A
- Electronic trip unit from 125 A, 160 A, 400 A, 500 A, 630 A, 800 A
- Wide range of accessories.

Rated ultimate breaking capacity at 800 V AC

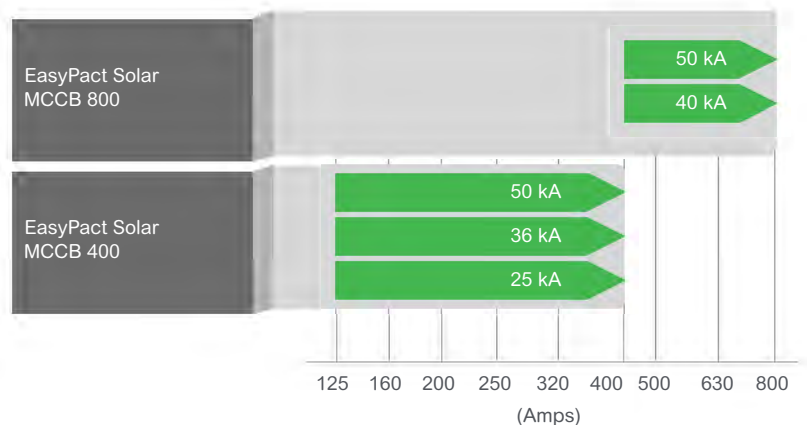

EasyPact Solar MCCB



The EasyPact Solar range of Molded Case Circuit Breaker (MCCB) is a culmination of innovation. Designed to meet the requirements of today's evolving electrical systems installations.

Considering the changing expectations of customers and a need for an affordable and reliable solution, we introduce the EasyPact Solar range of MCCBs with operational voltages up to 800 V, insulation voltage up to 1250 V and higher breaking capacities up to 50 kA at 800 V AC.

The thermal magnetic trip units offer comprehensive protection for all needs. System designers and users can choose and implement the protection schemes fitting to their needs.

EasyPact Solar MCCB 400 & 800 equipped with electronic trip unit offers advanced protection.

+

Schneider Electric do not recommend the mix of different range of circuit breakers.

Features

- Double break contact system for all EasyPact Solar MCCB 400 and 800
- Range from 125 to 800 A available in 3 pole 3D
- Protection using both TMD thermal magnetic trip unit and electronic trip unit
- Various types of power connection
- High electrical and mechanical life
- Large coverage of operational voltages
- Wide range of internal and external accessories
- Compact size provided with double insulation
- Ideal for renewable applications

Codes and standards

EasyPact Solar MCCB series and auxiliaries comply with:

- IEC 60947-1: General rules
- IEC 60947-2: Circuit-breakers
- IEC 60947-5-1: Control circuit devices and switching elements
- Electromechanical control circuit devices

EU Declaration of Conformity:

Environment:

EasyPact Solar MCCB series respects the European directives 2011/65/EU and 2015/863/EU concerning the restriction of hazardous substances (RoHS).

WEEE Directive:

EasyPact Solar MCCB series respects the European directives 2014/35/EU concerning on managing the waste of electrical and electronic equipment.

Power connection options:

Terminal extension spreaders.

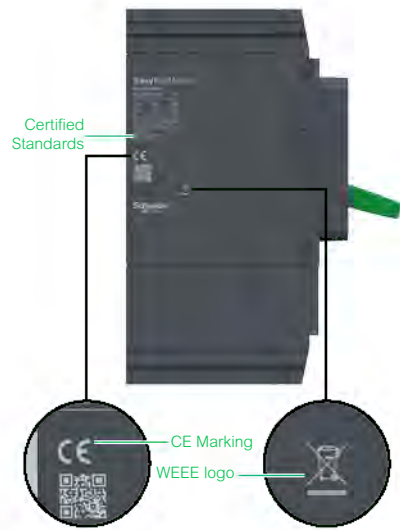

EasyPact Solar MCCB 400	
Trip unit	TMD Adjustable & ETU
Current rating	125 A - 400 A
Breaking capacity (Icu) at 800 V AC	25 kA - 50 kA
EasyPact Solar MCCB 800	
Trip unit	ETU
Current rating	400 A - 800 A
Breaking capacity (Icu) at 800 V AC	36 kA - 50 kA

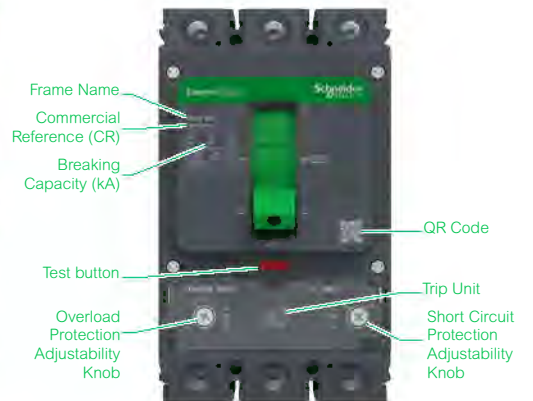

EasyPact Solar MCCB will not provide Selectivity or Cascading table. Please contact your sales representative or customer care center for more information.

WEEE¹: Waste Electrical and Electronic Equipment Recycling



Learn more about
EasyPact
Solar MCCB
range here



Offer



Catalogue

Scan or click on QR code

If you need more details about product references and availability, please check your local Schneider Electric contact <https://www.se.com/ww/en/work/support/country-selector/contact-us.jsp>



A

B

C

D

E

F

G

H

I

J

Power monitoring and power quality

PowerLogic™	
General overview	C-184
Selection guide	C-188
EcoStruxure™ Panel Server	
General overview	C-196
Architecture overview	C-198
Technical characteristics	C-199
HeatTag	
General overview	C-202
Functions and characteristics	C-204
EasyLogic Power Metering	
General overview	C-206
Functions and characteristics	C-209
EasyLogic PFC Capacitors	
General overview	C-214
Technical characteristics	C-218
EasyLogic™ APF	
General overview	C-224
Technical characteristics	C-226
Vigilohm	
General overview	C-228
Applications	C-230
Range overview	C-231
Selection guide	C-233



A

B

C

D

E

F

G

H

I

J



Energy management, revenue metering and power quality monitoring

Electrical network management

PowerLogic technology forms one part of your total energy management solution from Schneider Electric. As the global energy management specialist, we offer end-to-end power, building and process management solutions that help you optimize energy use and costs, improve performance, enhance comfort and safety, and deliver uninterrupted service while taking responsible care of our planet.

Our expert services can help you audit your energy use and build your energy action plan. From power factor correction systems, harmonic filtering and variable speed drives to HVAC and lighting controls, we offer a complete range of energy efficient technologies.

PowerLogic™ System is...

Schneider Electric believes every business can increase productivity while consuming less and achieving energy savings of 10% to 30%.

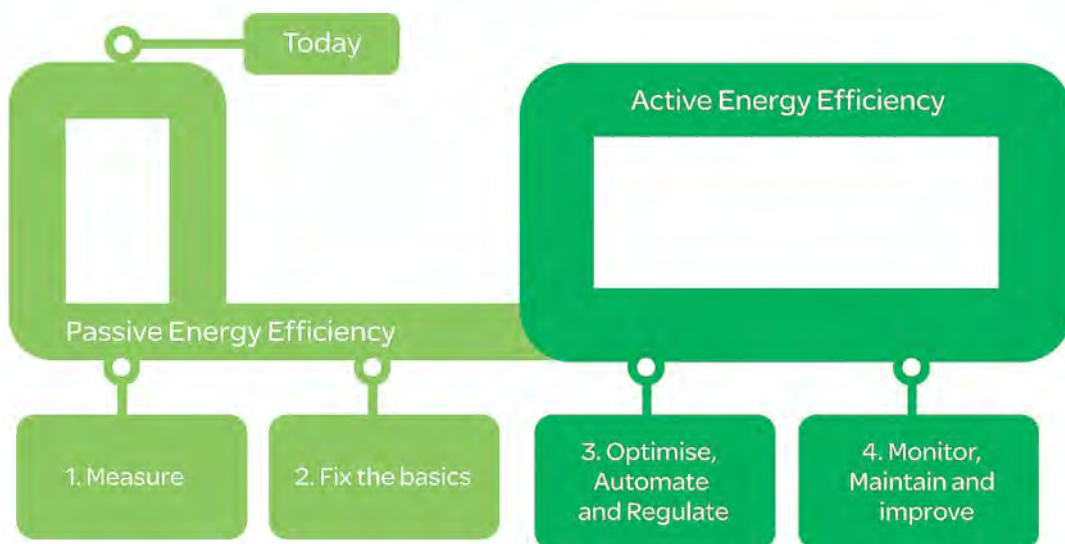

- Saving energy reduces costs and pollution, but you need the tools to uncover all opportunities, avoid risks, track progress against goals, and verify success. Schneider Electric provides these tools via the world's most advanced energy intelligence technology: PowerLogic.
- A PowerLogic system of meters, software and power quality solutions help manage all energy assets, every second of the day. A PowerLogic system enables all stakeholders, from CEO to facility and engineering managers, to respond quickly to potential problems and manage energy in financial and environmental terms.
- PowerLogic technology delivers the key performance indicators and analytics that you need to strategically balance emissions, efficiency, reliability and cost.

A

Gain energy insight and control with PowerLogic™ systems

B

Cutting-edge technology to increase profitability

PowerLogic technology converts the complex dynamics governing the relationship between power generation and distribution on the utility side, and energy consumption, cost and reliability on the consumer side, into timely, easily understood information. Businesses can use this powerful to improve tactical actions and strategic decision making.

C

From a single facility to an entire enterprise, PowerLogic meters monitor key distribution points 24 hours a day. Whether from generators, substations, service entrances, mains, feeders, loads or 3rd party equipment and systems, PowerLogic technology tracks, records and reports all real-time conditions and historical performance data. Intuitive web-based interfaces give stakeholders access to this data as well as advanced analytics, alarm annunciation and control capabilities. It supports comprehensive energy management programs by tracking performance and empowering you to make effective decisions.

D

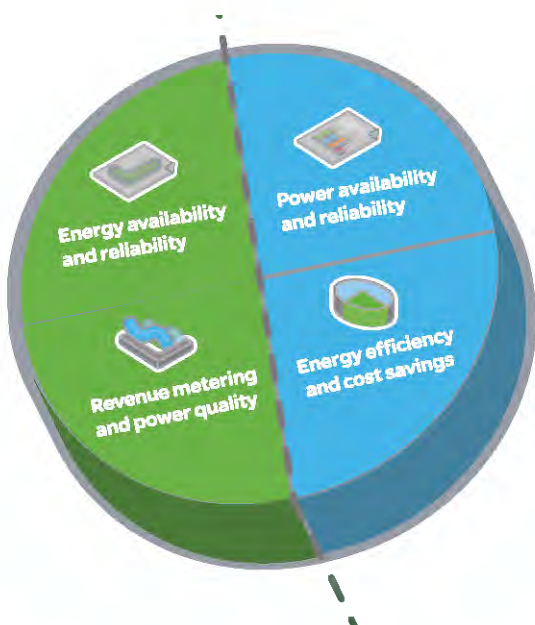

E

Demand

Power availability and reliability

- Validate that power quality complies with the energy contract
- Identify power quality issues and fix them quickly with reliable mitigation solutions
- Improve response to power-related problems
- Leverage existing infrastructure capacity and avoid over-building
- Support proactive maintenance to prolong asset life

F

Energy efficiency and cost savings

- Measure efficiency, reveal opportunities and verify savings
- Manage greenhouse gas emissions
- Allocate energy costs to departments or processes
- Reduce peak demand and power factor penalties
- Enable participation in loadcurtailment programs (e.g. demand response)
- Strengthen rate negotiation with energy suppliers
- Identify billing discrepancies
- Sub-bill tenants for energy costs

G

Supply

Energy availability and reliability

- Improve T&D network reliability
- Enhance substation automation
- Maximize the use of your existing infrastructure

H

Revenue metering and power quality

- Maximize metering accuracy at all interchange points
- Verify compliance with new power quality standards
- Analyse and isolate the source of power quality problems

I

J

Market segments



- Cost allocation
- Procurement optimization
- Power factor correction
- Continuity of service even in case of an earth fault.

- Tenant sub-billing
- Cost allocation
- Energy efficiency & benchmarking
- Procurement optimization
- Power availability
- Demand response / load curtailment.



- Metering all key interchange points with the highest possible accuracy
- Improving the quality of power delivered to your customers
- Ensuring the reliability and efficiency of your network and equipment.

- Revenue metering
- Power quality monitoring
- Power availability and reliability
- Insulation monitoring.

- Infrastructure optimization
- Power quality analysis compliance
- Alarming and event notification
- Energy efficiency
- Cost allocation
- Procurement optimization.







Use this panorama to select the most efficient products for your application needs

5 A Current transformers						
						
	METSECT5CCXXX	METSECT5DXXXX	METSECT5MXXXX	METSECT5VXXXX	METSECT5GXXXX	METSECT5HXXXX
Type	Solid Core	Solid Core	Solid Core	Solid Core	Solid Core	Solid Core
Electrical characteristics						
Primary Current	40 A to 250 A	500 A to 4000 A	150 A to 800 A	5000 A to 6000 A	100 A to 4000 A	100 A to 1000 A
Secondary Output	5 A	5 A	5 A	5 A	5 A	5 A
Accuracy Class	Class 0.5 to Class 3	Class 0.5 to Class 1	Class 0.5 to Class 1	Class 0.5	Class 0.5 to Class 3	Class 0.5 to Class 1
Profile Suitable	Cable	Bar	Bar/Cable	Bar	Bar	Cable
Operating Temperature	-25 to 60°C	-25 to 60°C	-25 to 60°C	-25 to 50°C	-5 to 40°C	-5 to 50°C

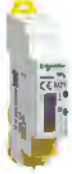
LVCT - 0.333 V			Rogowski Coils	
				
	METSECTLV25020U	METSECTLV1010U + METSECTLV4080U	METSECTVXXXXX	METSECTR90500U
Type	Solid Core	Solid Core	Solid Core	Rogowski Coils
Electrical characteristics				
Primary Current	50 A to 400 A	50 A to 2400 A	60 A to 250 A	50 A to 5000 A
Secondary Output	0.333 V	0.333 V	0.333 V	58.3 mV/kA to 50 Hz 70 mV/kA to 60 Hz
Accuracy Class	Class 1	Class 1	Class 1	Class 1 A1
Profile Suitable	Cable	Bar	Bar/Cable	Bar
Operating Temperature	-40 to 85°C	-15 to 60°C	-25 to 55°C	-35 to 60°C



Basic energy metering					
					
	iEM2xxx Range iEM2000, iEM2400	iEM3000 Series	PM3000 Series	EM3000 Series	PowerTag Energy Series
Function	Kilowatt-hour meter	Kilowatt-hour meters Power and energy meters	Metering & sub- metering Class 0.5S IEC 62053-22 Class 1 IEC 62053-21 Class 2 IEC 62053-23	Kilowatt-hour meters Power and energy meters	Wireless power & energy meter
Applications					
Panel instrumentation					
Panel instrumentation	E (in all range) I, U, F, P, Q, S, PF (in selected ranges)	I, U, F, P, Q, S, PF, E (Power demand and current demand)	I, U, F, P, Q, S, PF, E (Power demand and current demand)	I, U, F, P, Q, S, PF, E (Power Demand and current demand)	I, U, F, P, Q, S, PF, E (Depending on reference; Power demand depending on gateway)
Energy efficiency and cost					
Sub-billing & cost allocation	⊙	⊙	⊙	⊙	Cost allocation only
Demand & load management		⊙		⊙	
Billing analysis		⊙		⊙	
Power availability & reliability					
Compliance monitoring					
Dip/swell, transient					
Harmonics					
Revenue metering					
Revenue meter					
Characteristics					
Measurement accuracy	Class 1 (Wh) / Class 2 (VARh)	Class 0.5S / Class 1 (Wh) Class 2 (VARh)	Class 0.5	Class 0.5/ 0.5s/ Class 1 (Wh) Class 2 (VARh)	IEC 61557-12 PMD/DD Class 1 (active energy)
Installation	DIN rail 1, 2 x 18 mm modules	DIN rail 5, 7 x 18 mm modules	DIN rail	DIN rail 5 x 18 mm modules	On product or on cables depending on the reference
Voltage measurement	Up to 276 V (Ph-N) AC direct	100 - 277 V L-N, 173 - 480 V L-L Up to 1MV AC (ext VT)	50 V to 330 V AC (Ph-N) 80 V to 570 V AC (Ph-Ph) Up to 1M V AC (ext VT)	90 - 347 V L-N- EM3570 156 - 600 V L-L- EM3570 100 - 277 V L-N (Others) 173 - 480 V L-L (Others)	Up to 277 V AC (Ph-N) / 480 V AC (Ph-Ph) depending on the reference
Current measurement	40 to 125 A direct	External CT (iEM32/34/3500) Direct 63 A (iEM3100), 125 A (iEM3300)	External CT	45 A Direct - EM3100 63 A Direct - EM3200 100 A Direct - EM3300 125 A Direct - EM3400 LVCT/Rog - EM3570 External CT (1/5 A) - EM3700	63 to 2000 A
Communication ports	RS-485, M-Bus in selected references	RS-485, M-Bus, BACnet, LonWorks in selected references	1	RS485, Dual Ethernet Port (EM3570)	Wireless
Inputs / Outputs	1/1 (in selected)	Up to 2 Inputs and 1 Output	2 I/O	Up to 2 Inputs and 1 Output	
Memory capacity					

A

B

C

D

E





F

G

H

I

J

	Wireless products		Basic multi-function metering	
		 <small>More details on page 202</small>		
	PowerTag Control	HeatTag Smart Sensor	PM5000 Series	PM5350 Series
Function	Circuit monitoring & control IEC 60364-8-1 EN 17267 ISO 50010	Early detection of overheating wire connections or overheating cables	Metering & sub-metering Class 0.5S IEC 62053-22 Class 1 IEC 62053-21 Class 2 IEC 62053-23 Class 0.5/1 IEC 61557-12	Class 0.5S IEC 62053-22 Class 2 IEC 62053-23 Class 1 IEC 61557-12
Applications	Panel instrumentation			
Panel instrumentation		Analysis of gas and micro-particles, Temperature, Humidity	I, U, F, P, Q, S, PF, E (Power demand and current demand)	I, U, F, P, Q, S, PF, E (Power demand and current demand)
Energy efficiency and cost	Sub-billing & cost allocation			
Sub-billing & cost allocation			⊙	⊙
Demand & load management			⊙	⊙
Billing analysis			⊙	
Power availability & reliability	Compliance monitoring			
Compliance monitoring			⊙	
Dip/swell, transient			⊙	
Harmonics			⊙	⊙
Revenue metering	Revenue meter			
Revenue meter				
Characteristics	Measurement accuracy			
Measurement accuracy		Temperature ±1.1°C Humidity ± 9 RH%	Class 0.5	Class 0.5
Installation	DIN rail	DIN rail 6 x 18 mm modules	Flush mount 96 mm x 96 mm or DIN rail (PM5563)	Flush mount 96 mm x 96 mm
Voltage measurement			20 V to 400 V AC L-N 35 V to 690 V AC L-L	20 V to 300 V L-N 35 V to 520 V L-L
Current measurement			External CT	External CT
Communication ports	Wireless		RS-485, Ethernet, BACnet, Ethernet IP	RS-485
Inputs / Outputs	2 I/O		Up to 4 inputs/ 2 outputs	Up to 4 inputs/ 2 outputs
Memory capacity			Available	

Advanced metering		
		
	PM8000 Series	ION9000
Function	Energy & Advanced Power Quality Meter IEC 62053-22 Class 0.2S ANSI C12.20 Class 0.2 IEC 61000-4-30 Class S IEC 62586-2 IEC 61557-12 PMD/Sx/K70/0.2 IEC / UL 61010-1	Energy & Advanced Power Quality Meter IEC62052-11 ed.2 Class 0.1S ANSI C12.20 Class 0.1 PQI Class A IEC 62586-1 / -2 IEC 61557-12 PMD/Sx/K70/0.2 IEC / UL 61010-1
Applications		
Panel instrumentation		
Panel instrumentation	I, U, F, P, Q, S, PF, E, THD, Min/Max, harm, alarm, I/O (I, U unbalance, demand, clock/cal, dip/swell)	I, U, F, P, Q, S, PF, E, THD, Min/Max, harm, alarm, I/O (I, U unbalance, demand, clock/cal, dip/swell, transients, flicker, RVC, mains signalling, 1/2 cycle RMS)
Energy efficiency and cost		
Sub-billing & cost allocation	<input checked="" type="checkbox"/>	<input checked="" type="checkbox"/>
Demand & load management	<input checked="" type="checkbox"/>	<input checked="" type="checkbox"/>
Billing analysis	<input checked="" type="checkbox"/>	<input checked="" type="checkbox"/>
Power availability & reliability		
Compliance monitoring	<input checked="" type="checkbox"/>	<input checked="" type="checkbox"/>
Dip/swell, transient	Dip/swell only	<input checked="" type="checkbox"/>
Harmonics	<input checked="" type="checkbox"/>	<input checked="" type="checkbox"/>
Revenue metering		
Revenue meter		
Characteristics		
Measurement accuracy (active energy)	IEC 62053-22 Class 0.2S ANSI C12.20 Class 0.2	IEC62052-11 ed.2 Class 0.1S ANSI C12.20 Class 0.1
Installation	Flush & DIN 96 mm x 96 mm	Flush & DIN 160 mm x 160 mm Display 96 mm or 197 mm x 175 mm
Voltage measurement	57-400 V AC L-N 3P (100-690 V AC L-L)	57-400 V L-N AC or 100-690 V L-L AC
Current measurement	External CT	External CT and LVCT
Communication ports	3	4
Inputs / Outputs	Up to 27 DI, 9 DO Up to 16 AI, 8 AO	Up to 32 DI, 4 DO, 10 RO (relay) Up to 16 AI, 8 AO
Memory capacity	512 MB	2 GB

A

B

C

D

E

F

G

H

I

J

A

B

C

D

E



F

G

H

I

J

	Advanced utility metering	Multi-circuit metering
	 <p>ION7400</p>	 <p>HDPM6000</p>

Function	Advanced utility metering	Multi-circuit metering
	Energy & Advanced Power Quality Meter IEC 61557-12 IEC 62053-22 IEC 61000-4-30 Class S IEC 62586 ANSI C12.20 Class 0.2 PMD/Sx/K70/0.2	3-phase power quality meter; branch-circuit accessory module hub

Applications		
Panel instrumentation		
Panel instrumentation	I, U, F, P, Q, S, PF, E, THD, Min/Max, harm, alarm, I/O (I, U unbalance, demand, clock/cal)	
Energy efficiency and cost		
Sub-billing & cost allocation	<input checked="" type="checkbox"/>	<input checked="" type="checkbox"/>
Demand & load management	<input checked="" type="checkbox"/>	<input type="checkbox"/>
Billing analysis	<input checked="" type="checkbox"/>	<input type="checkbox"/>
Power availability & reliability		
Compliance monitoring	<input checked="" type="checkbox"/>	<input type="checkbox"/>
Dip/swell, transient	Dip/swell only	
Harmonics	<input checked="" type="checkbox"/>	<input type="checkbox"/>
Revenue metering		
Revenue meter	<input checked="" type="checkbox"/>	<input type="checkbox"/>

Characteristics		
Measurement accuracy (active energy)	IEC 61053-22 Class 0.2S ANSI 12.20 Class 0.2S	
Installation	Flush & DIN rail mount 96 mm x 96 mm	
Voltage measurement	57-400 V AC L-N 3P (100-690 V AC L-L)	
Current measurement	External CT	
Communication ports	3	
Inputs / Outputs	Up to 27 DI, 9 DO Up to 16 AI, 8 AO	
Memory capacity	512 MB	

Retrofit products		
		
	EM3500	EM4200
Function	DIN rail power & energy meter ANSI 12.20 0.2% accuracy IEC 62053-22 Class 0.2S for EM35xx models ANSI C12.20 0.5% accuracy IEC 62053-22 Class 0.2S for EM35xxA models	Power & energy meter ANSI C12.20 0.2% IEC 62053-22 Class 0.2S
Applications		
Panel instrumentation	I, U, F, P, Q, S, PF, E (Power demand and current demand)	
Panel instrumentation	I, U, F, P, Q, S, PF, E (Power demand and current demand)	
Energy efficiency and cost		
Sub-billing & cost allocation	<input checked="" type="checkbox"/>	<input checked="" type="checkbox"/>
Demand & load management	<input type="checkbox"/>	<input type="checkbox"/>
Billing analysis	<input type="checkbox"/>	<input type="checkbox"/>
Power availability & reliability		
Compliance monitoring	<input type="checkbox"/>	<input type="checkbox"/>
Sag/swell, transient	<input type="checkbox"/>	<input type="checkbox"/>
Harmonics	<input type="checkbox"/>	<input type="checkbox"/>
Revenue metering		
Revenue meter	<input type="checkbox"/>	<input type="checkbox"/>
Characteristics		
Measurement accuracy	Class 1 (mains active energy)	ANSI C12.20 Class 0.2S IEC 62053-22 Class 0.2S
Installation	Panel or enclosure	DIN or screw, clip-on or hook
Voltage measurement	UL: 90 V L-N to 600 V L-L; CE: 90 V L-N to 300 V L	890 - 480 V AC L-L
Current measurement	EM35xxA models work exclusively with Rogowski coil CTs	5 A to 5000 A
Communication ports	1 for main	2
Inputs / Outputs	(see Datasheet)	
Memory capacity		

A

B

C

D

E

F



G

H

I

J

A
B
C
D
E
F
G
H
I
J

	Insulation monitoring Devices	EcoStruxure™ Panel Server
	 <p>Vigilohm™ Insulation monitoring devices</p>	 <p>EcoStruxure™ Panel Server</p> <p>More information on page 196</p>
Function	Insulation monitoring for IT / Ungrounded networks	IoT gateway for intelligent power network
Features	<p>RS-485 / Ethernet gateway</p> <p>Devices supported</p> <p>Web server with standard HTML pages</p> <p>Web server with custom HTML pages</p> <p>Real time data</p> <p>Historical data</p> <p>Automatic notification</p> <p>Alarm and event logs</p> <p>Waveform display</p> <p>Custom animated graphics</p> <p>Manual/automatic reports</p>	<p>Supports IEEE 802.15.4 and Modbus devices</p> <p>Wired devices communicating through Modbus-SL, Modbus TCP/IP, or digital inputs:</p> <p>Circuit breakers and switch-disconnectors, Protection relays, Power meters, Energy meters, Pulse meters, IO modules, Gateways</p> <p>Wireless devices:</p> <p>PowerTag Energy sensors, Environmental sensors, Acti9 Active, HeatTage sensors, PowerTag Control modules, Wireless indication auxiliaries for ComPacT NSX and ComPacT NSXm, circuit breakers</p> <p>Available on web server embedded in Panel Server</p> <p>Available on web server embedded in Panel Server (Advanced Panel Server only)</p> <p>Available on embedded web server (Advanced Panel Server only), edge control system & cloud-hosted application</p> <p>Available on embedded web server (Advanced Panel Server only), edge control system & cloud-hosted application</p>
Characteristics	<p>Ethernet ports</p> <p>Modbus TCP/IP protocol</p> <p>RS-485 (2-wire / 4-wire) ports, Modbus protocol</p> <p>Number of devices connected directly</p> <p>RS-232 configuration ports</p> <p>Miscellaneous</p> <p>Installation</p>	<p>An IT earthing system -also called ungrounded system- allows the network to operate even in the presence of an insulation fault, without endangering people or property. Required as part of the IT network, an Insulation Monitoring Device (IMD) detects the insulation fault and locates it so it can be repaired.</p> <p>Two Ethernet 10Base-T/100Base-T port</p> <p>Wi-Fi</p> <p>Bluetooth communication for commissioning</p> <p>Modbus RS485 serial communication</p> <p>IEEE 802.15.4 wireless communication</p> <p>Modbus TCP/IP server and client</p> <p>Support of HTTPS, NTP, SNTP, DHCP client and server with proxy management</p> <p>Modbus RS485 to Modbus/TCP Gateway</p> <p>Wireless devices concentrator to Modbus/TCP</p> <p>Two digital inputs (24 V DC version only) Commissioning through EcoStruxure™ Power Commission or through Embedded Web-Pages</p>



Learn more about PowerLogic™ range here



Offer



Catalogue

Scan or click on QR code



If you need more details about product references and availability, please check your local Schneider Electric contact <https://www.se.com/ww/en/work/support/country-selector/contact-us.jsp>



- A
- B
- C
- D
- E
- F
- G
- H
- I
- J



IoT for an intelligent power network

The EcoStruxure™ Panel Server is the next generation of gateway, providing a seamless connection of wired or unwired smart IoT devices to your edge control software or cloud-based applications and analytics. It is a foundational enabler for Schneider Electric EcoStruxure™ solutions.



[SEE THE VIDEO](#)

EcoStruxure Panel Server gives you access to the information you need to protect, maximize and optimize your power system.

-  Help keep people and assets safer
-  Optimize energy efficiency
-  Maximize power availability
-  Improve cybersecurity



EcoStruxure™ Panel Server

Electrical safety

- Panel Server is an integral part of Schneider Electric’s continuous thermal monitoring application, helping reduce risk of electrical fires, increase people and assets protection. Implement the thermal monitoring of your electrical panel by connecting thermal and heat sensors to your Panel Server.



Power availability

- Electrical distribution monitoring and power event analysis help avoid unplanned downtime caused by electrical failure. Panel server collects real-time data and alarms, presenting information through embedded webpages, making it available to edge control software or cloud-based applications and analytics for electrical system diagnostics. Use embedded webpages for first-level monitoring or monitor from your edge or cloud control system.



Optimize energy efficiency

- Improve your facility’s energy efficiency and reduce energy consumption with energy usage analysis and performance tracking. Panel Server collects and shares energy data to help achieve your energy conservation initiatives. It is certified as part of an energy data management system certified for compliance with ISO 50001, 50002, 50006 requirements.



Cybersecurity

- Guarding your electrical assets and systems against cyber attacks is vital. Discover the enhanced cybersecurity benefits of Panel Server and its IEC62443-4-1 compliant development lifecycle. Explore its cybersecurity features through a [dedicated guide](#), and discover how Panel Server empowers you to retrieve security logs, providing valuable insights into system security and activity.



Benefits

All-in-one gateway

- Separates your OT network from your IT network
- Wireless data concentrator
- Modbus RS485 to Modbus TCP/IP
- Supports multiple Ethernet connections for serving information to edge control software and cloud applications

Intuitive operation

- User-friendly webpages offer first-level monitoring
- Contextualized data and operational insights
- Simple alarm setup for email notification
- Standardized IEC 62974-1 compliant datalogger and energy server

Simple commissioning

- EcoStruxure™ Power Commission software
- Device auto discovery
- Generation of acceptance reports to validate gateway configuration
- Commissioning via Ethernet or Wi-Fi infrastructure
- Mobile Commissioning via Wi-Fi Access point



EcoStruxure™ Panel Server

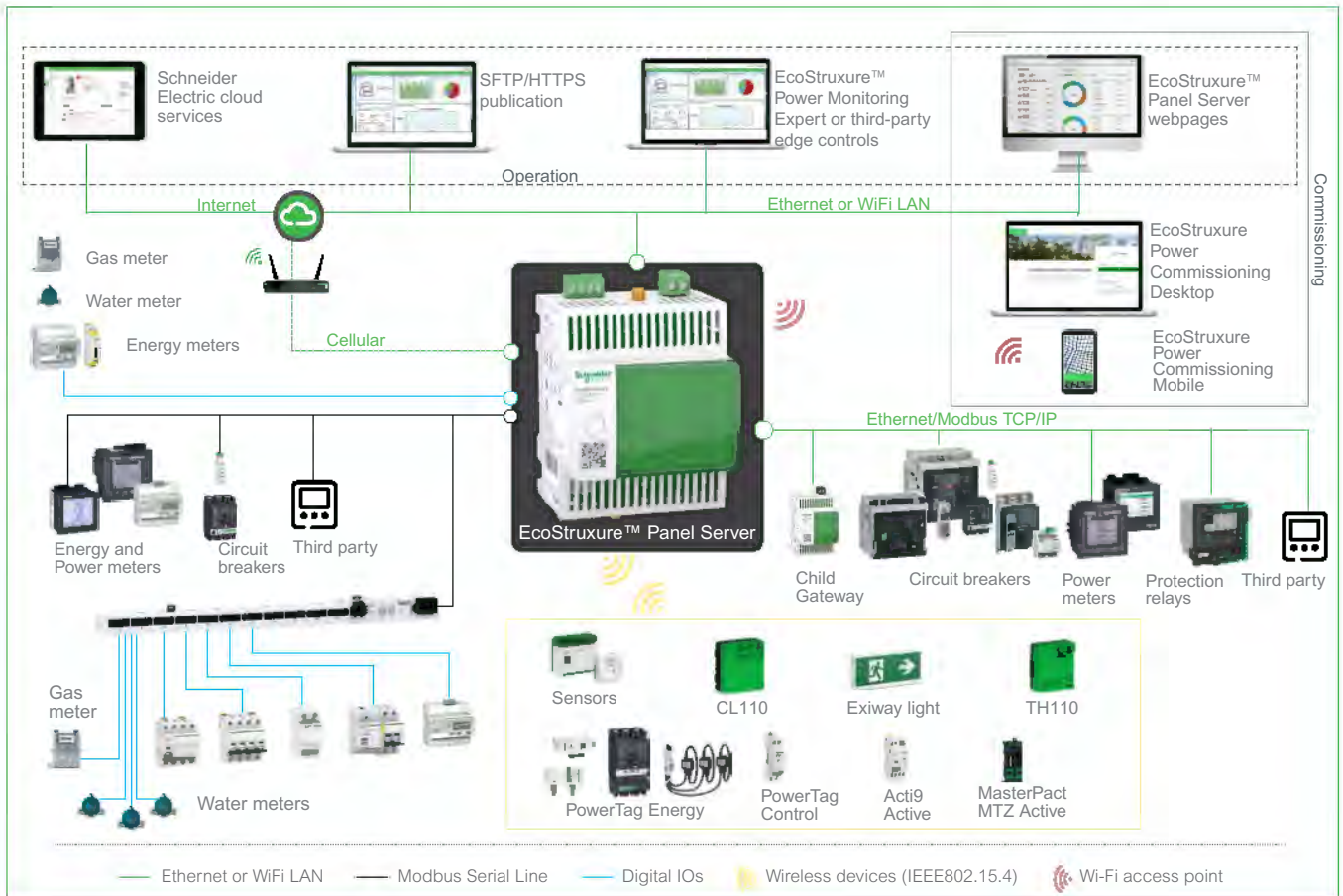

- A
- B
- C
- D
- E
- F
- G
- H
- I
- J

Technical characteristics

EcoStruxure™ Panel Server Entry



Standards & certifications

- IEC 61010-1
- IEC 61010-2-201
- UL 61010-1
- UL 61010-2-201
- IEC 62974-1
- ETSI EN 301 489-1 V.2.2.3
- ETSI EN 301 489-17 V.3.2.4
- IEC 61326-1
- IEC 62974-1
- EN50581
- EN 62321
- EN 62474
- ETSI EN 300 328 V2.2.2



Compatible with a large set of wireless sensors, PowerTag Energy, Heat Tag, and others. PAS400 is the perfect fit for small networks or installations where space is a challenge.

Functions

- Optimized gateway to retrieve data from your wireless devices.
- Connect to your monitoring and control software such as EcoStruxure™ Power Monitoring Expert, EcoStruxure™ Power Operation or to your Building Management System.
- Connect to Schneider Electric cloud applications such as EcoStruxure™ Energy Hub or Asset Advisor.
- Ease of commissioning with EcoStruxure™ Power Commission software or directly through the Panel Server webpages, enabling device plug-and-play and auto-discovery features.
- Ease of operation with user friendly embedded webpages, and data contextualization for more relevant analytics.

Main features

- Power Supply 110...277 V AC/DC
- Designed to match with electrical switchboard environment (temperature, humidity electromagnetic compatibility)
- One Ethernet 10Base-T/100Base-T port
- Wi-Fi
- IEEE 802.15.4 wireless communication
- Modbus TCP/IP server
- Support of HTTPS, NTP, SNTP, DHCP client with proxy management
- Wireless devices concentrator to Modbus TCP/IP
- Designed through a Secured Development Life Cycle in accordance to IEC 62443-4-1
- Commissioning through EcoStruxure™ Power Commission or through Embedded Web-Pages
- Speed-up commissioning through device list import and configuration export to the monitoring software
- Fully integrated in Cybersecurity Admin Expert tool to facilitate the management of cybersecurity in your electrical network's (Security features such as enabling/disabling communication means).
- Embedded web server for real-time measurement visualization, and power consumption
- Real-time alarm display

Commercial Reference	Description
PAS400	Panel Server Entry 110...277 V AC/DC



Technical characteristics

EcoStruxure™ Panel Server Universal



Standards & certifications

- IEC 61010-1
- IEC 61010-2-201
- UL 61010-1
- UL 61010-2-201
- IEC 62974-1
- ETSI EN 301 489-1 V.2.2.3
- ETSI EN 301 489-17 V.3.2.4
- IEC 61326-1
- IEC 62974-1
- EN50581
- EN 62321
- EN 62474
- ETSI EN 300 328 V2.2.2



All-in-one and Wired by Design Panel Server

- The All-in-one Panel Server Universal, PAS600, PAS600L, PAS600P and are designed to retrieve data from wireless, Modbus, and Ethernet based protocols to offer versatility and adaptability.
- Panel Server Universal Wired by Design, PAS600LWD and PAS600PWD, are designed for specific cybersecure sensitive installations, dedicated to wired communication protocols (Modbus, Ethernet) and PAS embedded digital inputs (PAS600LWD).

Functions

- Connect to your monitoring and control software such as EcoStruxure™ Power Monitoring Expert, EcoStruxure™ Power Operation or to your Building Management System.
- Connect to Schneider Electric cloud applications such as EcoStruxure™ Energy Hub or Asset Advisor.
- Ease of commissioning with EcoStruxure™ Power Commission software or directly through the Panel Server webpages, enabling device plug-and-play and auto-discovery features.
- Ease of operation with user friendly embedded webpages, And data contextualization for more relevant analytics.

Main features

- Power Supply 24 Vdc, 110...277 Vac/dc, PoE-PD (CLASS 0 and IEEE 802.3af/at)
- Designed to match demanding electrical switchboard environment (temperature and humidity electromagnetic compatibility).
- Two Ethernet 10Base-T/100Base-T port (supporting switched or separated network topology).
- Connect easily to the embedded webpages through your Wi-Fi Infrastructure (All-in-one Panel Server) or Ethernet connection.
- Modbus RS485 serial communication
- IEEE 802.15.4 wireless communication (All-in-one Panel Server Universal).
- Modbus TCP/IP server and client
- Support of HTTPS, NTP, SNTP, and DHCP client with proxy management.
- Modbus RS485 to Modbus TCP/IP Gateway
- Wireless devices concentrator to Modbus TCP/IP. (All-in-one Panel Server Universal)
- Two digital inputs (24 Vdc version) for contact information or WAGES pulse meter.
- Designed through a Secured Development Life Cycle in accordance to IEC 62443-4-1.
- Commissioning through EcoStruxure™ Power Commission or through Embedded Web-Pages.
- Wi-Fi Access point connection for seamless commissioning with EPC-Mobile (All-in-one Panel Server Universal).
- Support for RSTP protocol to help IT specialists re-establish communication paths through Ethernet after an interruption is detected.
- Embedded web server for real-time measurement visualization, and power consumption.
- Real-time alarm display

Accessories for All-in-one Panel Server Universal

- Wi-Fi external antenna (PASA-ANT1) for PAS600, PAS600P and PAS600L
- IEEE 802.15.4 external antenna (PASA-ANT1) for PAS600, PAS600P and PAS600L depending on hardware version [+1]

Commercial References	Description
PAS600	Panel Server Universal with 110...277 V AC/DC power supply
PAS600L	Panel Server Universal with 24 V DC power supply
PAS600P	Panel Server Universal with PoE power supply
PAS600LWD	Wired by Design Panel Server Universal with 24 V DC Power
PAS600PWD	Wired by Design Panel Server Universal with PoE power supply

Technical characteristics

EcoStruxure™ Panel Server Advanced



Panel Server has Data Logger and Local Energy Server capabilities. It embodies the first step into energy monitoring. Follow, analyze and compare your loads consumption to enable energy savings.

Functions

- An all-in-one gateway to retrieve data from both your wireless IEEE 802.15.4 devices and Modbus devices.
- Monitor up to three years historized data and analyze your energy consumption directly through the Panel Server Advanced embedded webpages.
- Connect to your monitoring and control software such as EcoStruxure™ Power Monitoring Expert, EcoStruxure™ Power Operation or to your Building Management System.
- Connect to Schneider Electric cloud applications such as EcoStruxure™ Energy Hub or Asset Advisor.
- Ease of commissioning with EcoStruxure™ Power Commission software or directly through the Panel Server webpages, enabling device plug-and-play and auto-discovery features.
- Ease of operation with user friendly embedded webpages, and data contextualization for more relevant analytics.

Standards & certifications

- IEC 61010-1
- IEC 61010-2-201
- UL 61010-1
- UL 61010-2-201
- IEC 62974-1
- ETSI EN 301 489-1 V.2.2.3
- ETSI EN 301 489-17 V.3.2.4
- IEC 61326-1
- IEC 62974-1
- EN50581
- EN 62321
- EN 62474
- ETSI EN 300 328 V2.2.2



Main features

- Power Supply 24 Vdc, 110...277 Vac/dc, PoE-PD (CLASS 0, IEEE802.3af/at)
- Designed to match demanding electrical switchboard environment (temperature, humidity electromagnetic compatibility)
- Two Ethernet 10Base-T/100Base-T port (supporting switched or separated network topology)
- Connect easily to the embedded webpages through your Wi-Fi Infrastructure or Ethernet connection
- Modbus RS485 serial communication
- IEEE 802.15.4 wireless communication
- Modbus TCP/IP server and client
- Support of HTTPS, NTP, SNTP, and DHCP client with proxy management
- Modbus RS485 to Modbus TCP/IP Gateway
- Wireless devices concentrator to Modbus TCP/IP
- Two digital inputs (24 Vdc version only) for contact information or WAGES pulse meter
- Designed through a Secured Development Life Cycle in accordance to IEC 62443-4-1
- Commissioning through EcoStruxure™ Power Commission or though Embedded Web-Pages
- Wi-Fi Access point connection for seamless commissioning with EPC-Mobile
- Support for RSTP protocol to help IT specialists re-establish
- Communication paths through Ethernet after an interruption is detected
- Embedded web server for real-time measurement and alarm visualization, energy and power consumption by usage and location, 3 years historical trending and dashboarding
- 3 years Data Logger with 32 GB memory
- Real-time alarm display and e-mail notification
- Event and alarm historization and dashboarding

Compatible accessories

- Wi-Fi external antenna (PASA-ANT1)
- IEEE 802.15.4 external antenna (PASA-ANT1)

Commercial References	Description
PAS800L	Panel Server Advanced with 24 V DC power supply
PAS800P	Panel Server Advanced with PoE power supply
PAS800	Panel Server Advanced with 100-277 V AC/DC power supply

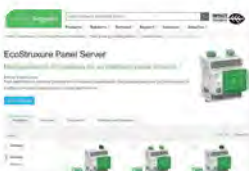

Learn more about EcoStruxure Panel Server range here



Offer



Catalogue

Scan or click on QR code

If you need more details about product references and availability, please check your local Schneider Electric contact <https://www.se.com/ww/en/work/support/country-selector/contact-us.jsp>



PowerLogic™ HeatTag

- A
- B
- C
- D
- E
- F
- G
- H
- I
- J



Wireless Sensor for early detection of overheating cables

The PowerLogic™ HeatTag sensor analyzes gas and airborne particles helping facility manager to anticipate and act before smoke appears or an electrical fire starts.

Electrical fires generate huge losses in commercial and industrial buildings, interrupting production and delaying service delivery. These losses can be prevented if early detection of component overheating is accurately detected and alarmed.

PowerLogic™ HeatTag helps prevent electrical cabinets from being damaged by analyzing airborne gas and particles and sending alerts before smoke appears or an electrical fire starts. HeatTag is much more than a fire or smoke detector - it scientifically detects overheating in electrical installations before any damage is done.



[SEE THE VIDEO](#)

The solution for

Markets that can benefit from a solution that includes PowerLogic™ HeatTag smart sensors:

- Buildings
- Industry
- Healthcare
- Data Center and networks
- Infrastructure.

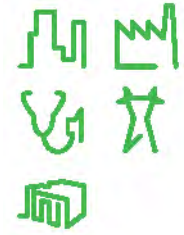

Power management solutions

• Schneider Electric provides innovative power management solutions to increase your energy efficiency and cost savings, maximize electrical network reliability and availability, and optimize electrical asset performance.



Competitive advantages

- Easy to install and operate
- Suitable for non forced ventilated cabinets ≥ IP30
- Immediately detects overheating in cables and connections
- More than a smoke detector or heat sensor
- 3 levels of alert recording
- Monitors air quality index
- Continuous improvements of algorithms.



Conformity of standards

- IEC/UL 61010-1
- IEC 61010-2-201
- IEC 61326-1
- IEC61326-2-3
- ETSI EN 301 489-1
- ETSI EN 301 489-17
- ETSI EN 300 328
- EN 62311
- EN IEC 63000
- IEEE 802.15.4 protocol
- FCC and IC certified.



Benefits

System integrators' benefit

- Ease of integration
- Ease of setup
- Cost effectiveness
- Seamless integration with EcoStruxure™ solutions

End users' benefit

- Ease of use
- Prevents fire damage and associated costs
- Comprehensive, consistent and superior performance
- Maximize uptime, eliminate faults, and enhance safety

Panel builders' benefit

- No settings
- Nominal environment auto-learning to avoid false alerts
- Concentrator auto-discovery
- Alerts generated by a powerful algorithm integrated in HeatTag

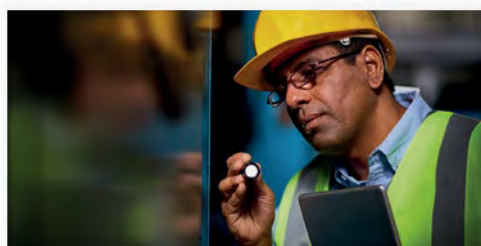

PowerLogic™ HeatTag

HeatTag sensors

A



PowerLogic™ HeatTag sensor

B



HeatTag sensor DIN mounted

C

D

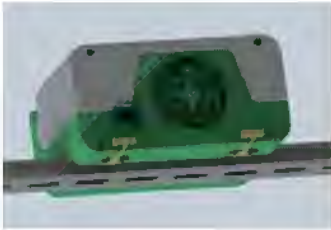

HeatTag rear view showing fan

E

F

G

H

I

J

Sensor Characteristics

Temperature measurement	Measurement range	-15°C / +70°C (5°F to 158°F)
	Measurement accuracy	-1.1°C / +1.1°C
	Default transmission period	60 seconds (higher in case of high wireless data traffic)
Humidity measurement	Measurement range	15 - 90%
	Measurement accuracy	±9 RH %
	Default transmission period	60 seconds (higher in case of high wireless data traffic)
Air quality		Index (0 to 10), alert generation when index ≥10
Test alert after pairing		During first 30 minutes
Environment auto-learning phase		8 hours after the first 30 minutes

Mechanical Characteristics

Dimensions (W x H x D)	108 x 107 x 55 mm
Weight	270 g
Degree of protection (IEC 60529)	IP20

Electrical Characteristics

Supply voltage	110 - 277 V AC, -15% / +15%
Frequency	50 - 60 Hz
Max. consumption	0.1 A
Operating temperature	-15°C / +70°C (5°F to 158°F)
Storage temperature	-20°C / +85°C (-4°F to 185°F)
Relative humidity in operation	15 - 90%
Altitude of use	0 - 2000 m (0 - 6500 ft)
Degree of pollution (IEC 60664-1)	3
Overvoltage category	OVC III

Commercial Reference Number

PowerLogic™ HeatTag Sensor	SMT10020
----------------------------	-----------------



Q1
110-277 V~
2 A
C Curve or Fast-acting fuse
L N

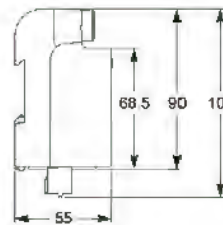

HeatTag sensor dimensions.
See the appropriate Installation Guide.

Functions and characteristics

PowerLogic™ HeatTag

HeatTag sensors

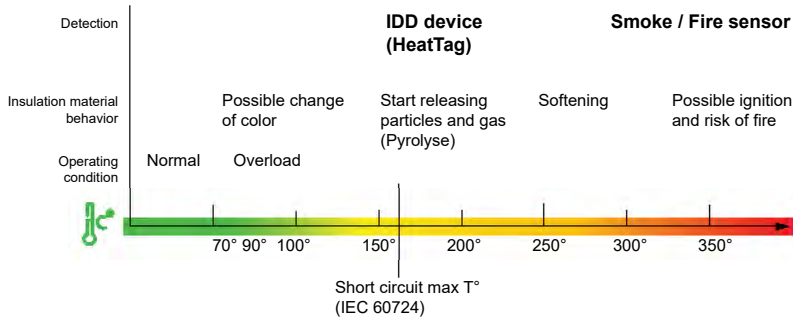

PVC insulation material behavior with increasing temperature

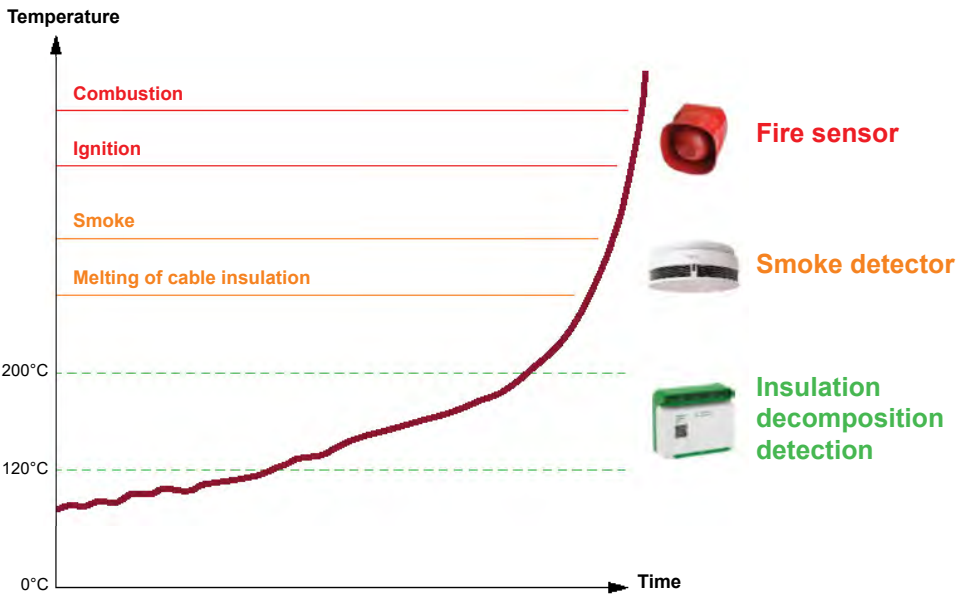

Comparison of HeatTag, smoke and fire sensors

NOTE

Do not use HeatTag as a safety device or to replace fire protection devices. Please see the appropriate User Guide for this product.



Learn more about PowerLogic™ HeatTag range here



Offer



Catalogue

Scan or click on QR code



If you need more details about product references and availability, please check your local Schneider Electric contact <https://www.se.com/ww/en/work/support/country-selector/contact-us.jsp>



- A
- B
- C
- D
- E
- F
- G
- H
- I
- J



Multifunction energy and power meters

The easy choice...

- for quality - Designed and manufactured in ISO-certified Schneider Electric facilities.
- for value - The right balance of features and price.
- for peace of mind - Reliable performance where you need it.

Leaner, more efficient order management thanks to field settable CT or PT ratios, modularity Fast and efficient installation & commissioning. Safety marks for CE and UL compliance in accordance with latest IEC/UL 61010-1 Ed-3 standard.

Performance without compromise - exceptional reliability in its class

- > Assured quality that you can trust to meet your needs throughout its lifecycle.
- > Outstanding value for an optimized feature set.
- > Simple to choose and easy to install and use for many applications.

Digital Panel Meters



Family	DM1000			DM3000		DM6000H	
Parameters	DM1110	DM1210	DM1310	DM3110	DM3210	DM6000H	DM6200H
Amps: per phase & 3-ph avg	1-ph			3-ph (per ph)		<input checked="" type="checkbox"/>	<input checked="" type="checkbox"/>
Volts: per phase & 3-ph avg		1-ph			3-ph (per ph)	<input checked="" type="checkbox"/>	<input checked="" type="checkbox"/>
Frequency			<input checked="" type="checkbox"/>			<input checked="" type="checkbox"/>	<input checked="" type="checkbox"/>
Power Factor per phase & 3-ph avg						<input checked="" type="checkbox"/>	<input checked="" type="checkbox"/>
CT Secondary I nominal	5 A or 1 A			5 A or 1 A		5 A or 1 A	5 A or 1 A
Class of Accuracy	0.5	0.5	0.2	0.5	0.5	1	1
RS-485 Modbus RTU							<input checked="" type="checkbox"/>
Form Factor in mm (LengthxWidthxDepth)	96x96x44	96x96x44	96x96x44	96x96x44	96x96x44	96x96x49	96x96x49
Mounting	Flush/Panel	Flush/Panel	Flush/Panel	Flush/Panel	Flush/Panel	Flush/Panel	Flush/Panel

Simple energy cost management

Data aggregation							<input checked="" type="checkbox"/>
Load profile							<input checked="" type="checkbox"/>
Bill verification							
Cost allocation							

Basic network management

Panel instrumentation	<input checked="" type="checkbox"/>	<input checked="" type="checkbox"/>	<input checked="" type="checkbox"/>	<input checked="" type="checkbox"/>	<input checked="" type="checkbox"/>	<input checked="" type="checkbox"/>	<input checked="" type="checkbox"/>
Power metering							
Basic harmonic monitoring							
Status monitoring							
Threshold alarming							

Monitoring and verification

Test bench	<input checked="" type="checkbox"/>	<input checked="" type="checkbox"/>	<input checked="" type="checkbox"/>	<input checked="" type="checkbox"/>	<input checked="" type="checkbox"/>	<input checked="" type="checkbox"/>	<input checked="" type="checkbox"/>
Genset	<input checked="" type="checkbox"/>	<input checked="" type="checkbox"/>	<input checked="" type="checkbox"/>	<input checked="" type="checkbox"/>	<input checked="" type="checkbox"/>	<input checked="" type="checkbox"/>	<input checked="" type="checkbox"/>
PF Improvement panel						<input checked="" type="checkbox"/>	<input checked="" type="checkbox"/>
Labs	<input checked="" type="checkbox"/>	<input checked="" type="checkbox"/>	<input checked="" type="checkbox"/>	<input checked="" type="checkbox"/>	<input checked="" type="checkbox"/>	<input checked="" type="checkbox"/>	<input checked="" type="checkbox"/>
OEMs	<input checked="" type="checkbox"/>	<input checked="" type="checkbox"/>	<input checked="" type="checkbox"/>	<input checked="" type="checkbox"/>	<input checked="" type="checkbox"/>	<input checked="" type="checkbox"/>	<input checked="" type="checkbox"/>
Commercial reference numbers	METSEDM1110	METSEDM1210	METSEDM1310	METSEDM3110	METSEDM3210	METSEDM6000HCL10NC	METSEDM6200 HCCL10RS (LED) METSEDM6220HCL1 (LCD)



EasyLogic Power Metering

Power & Energy Meters



Family	PM1120H/ EM1250H	PM1130H	PM2100 LED	PM2200 LCD
Parameters				
Amps: per phase & 3-ph avg	<input checked="" type="checkbox"/>	<input checked="" type="checkbox"/>	<input checked="" type="checkbox"/>	<input checked="" type="checkbox"/>
Volts: per phase & 3-ph avg	<input checked="" type="checkbox"/>	<input checked="" type="checkbox"/>	<input checked="" type="checkbox"/>	<input checked="" type="checkbox"/>
Frequency	<input checked="" type="checkbox"/>	<input checked="" type="checkbox"/>	<input checked="" type="checkbox"/>	<input checked="" type="checkbox"/>
Power Factor per phase & 3-ph avg	<input checked="" type="checkbox"/>	<input checked="" type="checkbox"/>	<input checked="" type="checkbox"/>	<input checked="" type="checkbox"/>
W, Wh	<input checked="" type="checkbox"/> ^[1]	<input checked="" type="checkbox"/>	<input checked="" type="checkbox"/>	<input checked="" type="checkbox"/>
VAR, VARh	<input checked="" type="checkbox"/> ^[1]	<input checked="" type="checkbox"/>	<input checked="" type="checkbox"/>	<input checked="" type="checkbox"/>
VA, VAh	<input checked="" type="checkbox"/> ^[1]	<input checked="" type="checkbox"/>	<input checked="" type="checkbox"/>	<input checked="" type="checkbox"/>
DI/DO (optional)			2 (PM2130)	2 (PM2230)
Class of Accuracy ^[1]	1.0 active (0.5 optional)	1.0 active (0.5 optional)	1.0 active (0.5S PM2x30) 1.0 reactive	1.0 active (0.5S PM2x30) 1.0 reactive
Analog IO A (optional)			2 (PM2130)	2 (PM2230)
RS-485 Modbus RTU	<input checked="" type="checkbox"/>	<input checked="" type="checkbox"/>	<input checked="" type="checkbox"/>	<input checked="" type="checkbox"/>
CT Secondary I nominal	5 A or 1 A	5 A or 1 A	5 A or 1 A	5 A or 1 A
Form Factor in mm	96x96x49	96x96x52	96x96x54	96X96X54
With IO module			96X96X72	96X96X72
Mounting	Flush/Panel	Flush/Panel	Flush/Panel	Flush/Panel

Simple energy cost management

Data aggregation	<input checked="" type="checkbox"/>	<input checked="" type="checkbox"/>	<input checked="" type="checkbox"/>	<input checked="" type="checkbox"/>
Load profile			<input checked="" type="checkbox"/>	<input checked="" type="checkbox"/>
Bill verification	<input checked="" type="checkbox"/>	<input checked="" type="checkbox"/>	<input checked="" type="checkbox"/>	<input checked="" type="checkbox"/>
Cost allocation	<input checked="" type="checkbox"/>	<input checked="" type="checkbox"/>	<input checked="" type="checkbox"/>	<input checked="" type="checkbox"/>

Basic network management

Panel instrumentation	<input checked="" type="checkbox"/>	<input checked="" type="checkbox"/>	<input checked="" type="checkbox"/>	<input checked="" type="checkbox"/>
Power metering	<input checked="" type="checkbox"/>	<input checked="" type="checkbox"/>	<input checked="" type="checkbox"/>	<input checked="" type="checkbox"/>
Basic harmonic monitoring	<input checked="" type="checkbox"/>	<input checked="" type="checkbox"/>	<input checked="" type="checkbox"/>	<input checked="" type="checkbox"/>
Status monitoring			<input checked="" type="checkbox"/>	<input checked="" type="checkbox"/>
Threshold alarming		<input checked="" type="checkbox"/>	<input checked="" type="checkbox"/>	<input checked="" type="checkbox"/>

Monitoring and verification

Test bench	<input checked="" type="checkbox"/>	<input checked="" type="checkbox"/>	<input checked="" type="checkbox"/>	<input checked="" type="checkbox"/>
Genset	<input checked="" type="checkbox"/>	<input checked="" type="checkbox"/>	<input checked="" type="checkbox"/>	<input checked="" type="checkbox"/>
PF Improvement panel	<input checked="" type="checkbox"/>	<input checked="" type="checkbox"/>	<input checked="" type="checkbox"/>	<input checked="" type="checkbox"/>
Labs	<input checked="" type="checkbox"/>	<input checked="" type="checkbox"/>	<input checked="" type="checkbox"/>	<input checked="" type="checkbox"/>
OEMs	<input checked="" type="checkbox"/>	<input checked="" type="checkbox"/>	<input checked="" type="checkbox"/>	<input checked="" type="checkbox"/>
Commercial reference numbers (Link to product information)	METSEPM1120HCL10RS METSEPM1125HCL10RS METSEPM1225HCL10RS METSEPM1125HCL1LVD METSEPM1225HCL1LVD METSEEM1250HCL1	METSEPM1130HCL05RS METSEPM1230HCL1 METSEPM1230HCL5LVD	METSEPM2110 METSEPM2120 METSEPM2130	METSEPM2210 METSEPM2220 METSEPM2230

^[*] Refer data sheet for operating range

One power vector at a time (W/Wh or VA/VAh or VAR/ VARh in PM1120H and Three power vector in PM1125H/ PM1225H)

^[1] Three power three energy

EasyLogic™ DM1000/3000 series

DM1000 series: 1-Ph V A F panel meters

DM3000 series: 3-Ph V A panel meters

The universal, user-programmable DM1000 and DM3000 series panel meters for AC circuits are ideal replacements for analog meters. These five compact, flexible and customizable models will meet all your panel metering requirements.



DM1000 series digital panel meter

Basic VAF panel meters - main features

- 4 digit, 15 mm height, 7 segment LED display
- 1-ph & 3-ph Volt or Amps panel meters
- Accuracy of 0.5% on full scale for Volt & Ammeter, 0.2% for Hz meter
- Inbuilt selector switch in 3-ph meter model
- Single key for programming, navigation or as selector switch.

EasyLogic™ DM6xx0H series

DM6000H & DM6200H VAF PF digital panel meters in LED display

DM6220H VAF PF digital panel meters in LCD display

Introducing EasyLogic™ DM6xx0H meters that are ideal replacements for multiple analog meters for stand-alone metering in custom panels, switch boards, switch-gear, genset panels, motor control centres, power factor improvement panels, and OEM panel board.

DM6xx0H series meters offer large 8-segment alpha-numeric LED display type, intuitive navigation with self-guided 4 buttons, bright LED's of 14.2 mm height with 12 LEDs for indicating percentage of load in the circuit.

DM6220H meter displays measured parameters and values in elegant single row, bright back lit graphical LCD display in 128 x 32 pixels size.



Applications

- Cost management
 - Electrical installation remote monitoring
 - Control panels
 - Motor control centres
 - Power distribution boards
- Original equipment manufacturers (OEM's)
- Building management system
- Panel instrumentation
- Energy management system.

Network management

- Measurement of Power factor
- % unbalance for voltage and current
- Phase angle between the respective voltage and current phase
- Modbus RTU protocol, RS-485 communication port for integration with energy management systems (DM6200H & DM6220H).

Functions and characteristics

EasyLogic Power Metering

EasyLogic™ EM1250H

EM1250H energy meters in LCD display

The EasyLogic™ EM1250H energy meter offers all the basic energy measurement capabilities required to monitor an electrical installation in a single 96 x 96 mm unit.

Characterized by their rugged construction, compact size, and low installation costs, these state-of-the-art meters are ideal for control panels, motor control centres, and genset panels.



EasyLogic™ meters are ideal replacements for multiple analog meters for stand-alone metering in custom panels, switch boards, switch-gear, genset panels, motor control centres, power factor improvement panels and OEM panel board.

Application

- Cost management applications
 - Measurement of basic electrical parameters in control panels, motor control panels, power distribution boards, OEM's, Building management systems, panel instrumentation
 - Aggregation of energy consumption and cost allocation per area, per usage, per shift and per time within the same facility.
- Network management applications
 - Measurement of Power factor
 - Modbus RTU protocol RS-485 communication port for integration with energy management system.

EasyLogic™ PM1000H series

The EasyLogic™ PM1000H basic power and energy meters with the option of LCD or LED Display

Offering all the measurement capabilities required to monitor the electrical installation in a single 96 x 96 mm unit, with 8 segment alphanumeric bright, large 14.2 mm high LED display (PM1125H) or with 128 x 32 pixels LCD display (PM1225H) options.



EasyLogic™ PM1125H/PM1225H meters are ideal replacements for multiple analog meters for stand-alone metering in custom panels, switch boards, switch-gear, genset panels, motor control centres, power factor improvement panels and OEM panel board.

Application

- Cost management applications
 - Measurement of basic electrical parameters in control panels, motor control panels, power distribution boards, OEM's, Building management systems, panel instrumentation
 - Aggregation of energy consumption and cost allocation per area, per usage, per shift and per time within the same facility.
- Network management applications
 - Power quality analysis (THD %)
 - Demand measurement
 - Measurement of Power factor
 - Phase angle between the voltage and current
 - % unbalance among voltage and current
 - Modbus RTU protocol RS-485 communication port for integration with energy management system.

The EasyLogic™ PM1130H/ PM1230H dual/ alternate source power and energy meters

Two energy registers (Utility vs Genset, Utility vs Solar, Utility vs Wind, or a combination of any two power sources) separately records consumption for dual source energy accounting. Ideal for any installation which requires split energy monitoring for two conditions, e.g., running and Idle. Form A relay to control the load in the event of abnormality in the electrical circuit including excess consumption of power. The meters can be used for secondary billing application in large commercial complexes or buildings as tenant meters in custom panels, switch boards, switchgear, genset panels, non-renewable energy panel and OEM panel board.

Offering all the measurement capabilities required to monitor the electrical installation in a single 96 x 96 mm unit, PM1130H with 8 segment alpha-numeric bright, large 14.2 mm high LED display.

PM1230H meter displays measured parameters and values in elegant single row, bright back lit graphical LCD display in 128 x 32 pixels size.



Application

- Cost management applications
 - Measure basic electrical parameters in control panels, power distribution boards, OEM's, and Building management systems
 - Aggregate energy consumption and cost allocation based on consumption from Utility vs Genset, or between any two power sources, per area, per shift and per time within the same facility.
- Network management applications
 - Power quality analysis (THD %)
 - Demand measurement
 - Measurement of Power factor
 - Phase angle between the voltage and current
 - % unbalance among voltage and current
 - Modbus RTU protocol RS-485 port for integration with energy management system.

Functions and characteristics

EasyLogic Power Metering

EasyLogic™ PM2000 series

The EasyLogic™ PM2000 multi-function power and energy meter

Offering all the measurement capabilities required to monitor and electrical installation in a single 96 x 96 mm unit, with LED or LCD display options.

Application

Cost management applications

- Bill checking to verify that you are only charged for the energy you use
- Aggregation of energy consumption, including WAGES, and cost allocation per area, per usage, per shift or per time within the same facility
- Energy cost and usage analysis per zone, per usage or per time period to optimise energy usage.

Network management applications

- Metering of electrical parameters to better understand the behaviour of your electrical distribution system
- Power quality analysis.



LCD display

LED display

Introducing EasyLogic PM2000 series, next generation power meter which offers all the measurement capabilities required to monitor an electrical installation in a single 96 x 96 mm unit. PM2000 meters are available in LED and LCD display variants.

PM2100 series

- LED display type: Intuitive navigation with self-guided, three buttons, bright red colour LEDs of 14.2 mm height. Two columns of LEDs indicate the parameter name chosen for display.

PM2200 series

- LCD display type: Monochrome graphical LCD of 128 x 128 pixels lets users read all three phase values simultaneously. The bright display enables easy reading even in extreme lighting conditions and viewing angles, with intuitive menus, multi-language text, icons and graphics.

Network management

- Power Quality analysis: THD % and individual harmonics to 15th or 31st order
- Measurement of True PF and Displacement PF
- Recording Min/Max values of instantaneous parameters with date and timestamp
- Optional IO modules comprising either 2 Digital Inputs and 2 Outputs, or 2 Analog Inputs and 2 Outputs, or 2 Digital Inputs and 2 Relay Outputs for comprehensive WAGES monitoring
- Calculates % unbalance for voltage & current
- Embedded 2 D/I and 2 R/O or 2 A/I and 2 A/O in PM2125 and PM2225 meters.

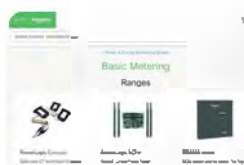

Learn more about
EasyLogic
Power Metering
range here



Offer



Catalogue

Scan or
click on
QR code

If you need more details about product references and availability, please check your local Schneider Electric contact <https://www.se.com/ww/en/work/support/country-selector/contact-us.jsp>

- A
- B
- C**
- D
- E
- F
- G
- H
- I
- J

A

B

C

D



E

EasyLogic PFC: The new generation LV power factor correction capacitors



F

What is power factor correction?

In electrical networks, reactive power and harmonics result in increased line currents for a given active power transmitted to loads. The principle of power factor correction is to reduce the apparent Power S (kVA for a given active Power P (kW).

Preliminary steps proposed to customers include power quality audits and the installation of power monitoring systems. This will provide comprehensive knowledge of the electrical installation characteristics in terms of power factor and harmonic distortion. Compensation of reactive power/energy or harmonic mitigation will be selected accordingly.

Compensation of reactive power/energy

An electricity bill generally includes components relating to active and reactive power (or energy) that has been absorbed over time.

Compensation of reactive energy is typically achieved by producing reactive energy close to the consuming loads through capacitor banks connected to the network. As a result, the energy supplier provides active energy only.

H

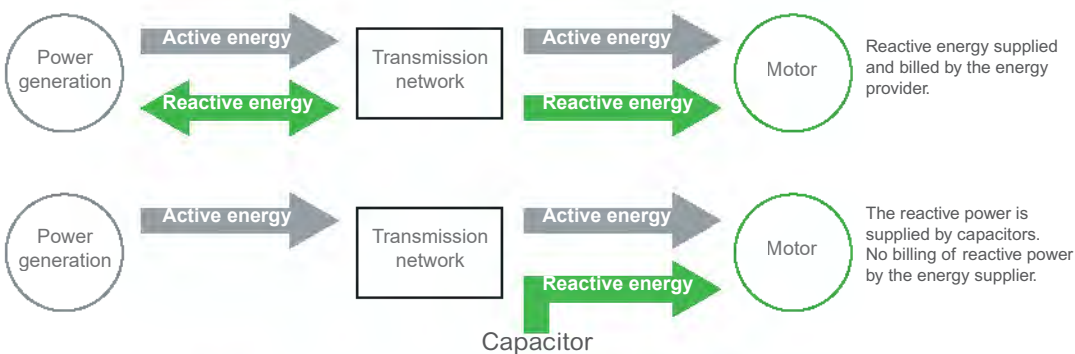

I

J

5 Easy Steps for Energy Efficiency



30%

weight and size reduction

100 k

lifetime hours

30%

more continuous current-carrying capacity

Easy installation

EasyLogic PFC Capacitor's optimised design reduces product size and weight by 30%, compared to the same rating of capacitor unit of the same class available in market. Its compact size helps to save panel space while its lower weight improves user experience during installation.

The EasyLogic PFC Capacitor capacitor's ergonomically designed Clamptite terminals also make handling simple and effortless. Its unique termination system is designed to maintain tightness and reduce the risk of loose connections.

Easy reliability & safety usage

EasyLogic PFC Capacitor capacitor offers exceptional reliability, extended life and high over-current capacity for handling slightly harmonic polluted networks. It gives a fail-safe performance and user confidence. EasyLogic PFC Capacitor has a three-phase design with a peripheral Pressure Sensitive Disconnection (PSD) mechanism. Schneider Electric has implemented a very stringent quality checking procedure to ensure consistency and reliability of the PSD mechanism. This independent mechanical component helps to disconnect the electricity supply automatically and has a guaranteed safe disconnection when the capacitor reaches the end of its life.



EasyLogic PFC Capacitors

5 Easy Steps for Energy Efficiency



100%

commitment to testing
ISO 9001, ISO 14000
and ISO 50001 quality
certified manufacturing

30%

energy wastage
reduction

A

B

C

D

E

Easy quality assurance

EasyLogic PFC Capacitor is manufactured in a state-of-the-art factory with advanced testing equipment to maintain product quality. All products are being fully tested before being sold, with seven testing stages for components and a two-stage final test, including component and film inspection, element and CD testing. EasyLogic PFC Capacitor capacitors meet the highest standards to satisfy worldwide requirements.

F

G

Easy saving

EasyLogic PFC Capacitor power correction capacitors can help to reduce up to 30% energy wastage. This consequently saves money and increases the available power in the network. The use of EasyLogic PFC Capacitor capacitors means electricity bill penalties are avoided and you can save more while spending less. Capacitor usage can reduce 1,000 kg of carbon footprint in a year, making it another easy way to protect the environment.

H

The compact size of EasyLogic PFC Capacitor capacitors (30% smaller than other similar models) helps to save up to 20% power panel space and maximises the utility of power usage for each area.

I

J

5 Easy Steps for Energy Efficiency

> Easy choice of components to optimise your solution.



PowerLogic PFC Detuned Reactors

This harmonic rated range of capacitors (480 V & 525 V) is dedicated to applications where a high number of non-linear loads are present.

These capacitors are designed for use with detuned reactors to deliver a perfect balance between performance and cost.

Schneider Electric's range of VarPlus Reactors should be associated with capacitor banks for Power Factor Correction in systems with significant non-linear loads, generating harmonics.

Capacitors and reactors are configured in a series resonant circuit, tuned so that the series resonant frequency is below the lowest harmonic frequency present in the system.

Capacitor Duty Contactors

Special contactors LC1 D•K are designed for switching three-phase, single- or multiple-step capacitor banks. They comply with IEC 60070 and 60831, NFC 54-100, VDE 0560, UL and CSA standards.

PowerLogic PFC Controller

The Varlogic controllers permanently monitor the reactive power of the installation, and control the connection and disconnection of capacitor steps in order to obtain the targeted power factor.

EasyPact MCCB

The **EasyPact** MCCBs acts as a overload and short circuit protector for individual capacitor bank, preventing disconnection of the bank in the event of overload due to harmonics or other fluctuations.

Use of MCCBs are highly recommended for every capacitor steps.



EasyLogic PFC Capacitors

Specifications

Construction	Extruded aluminium can
Voltage range	230 V - 525 V
Power range (Three Phase)	1 - 30 kvar
Peak inrush current	Up to $200 \times I_n$
Over voltage	$1.1 \times U_n$ As per IEC 60831- ½
Over current	$1.5 \times I_n$
Mean life expectancy	Up to 100,000 h
Discharge device	50 V / 1 min
Dielectric	Special profile Al/Zn Metalised Poly Propylene film
Impregnation	Non-PCB Biodegradable soft resin
Ambient temperature	-25°C to max 55°C
Protection	IP20 (Fast on and clampite type)
Mounting	1- point mounting, upright
Terminals	<ul style="list-style-type: none"> ■ Double fast-on + cable < 10 kvar ■ CLAMPTITE ≥10 kvar to 30 kvar ■ STUD TYPE for more than 30 kvar



Green innovation
RoHS and REACH
compliant



Technical characteristics

EasyLogic PFC Capacitors

Single Phase & Three Phase

An easy choice for savings which is optimized to deliver the performance you need. Suitable for standard operating conditions to deliver safe and reliable performance.



EasyLogic™ three phase



EasyLogic™ single phase

Operating conditions

- For networks with insignificant non-linear loads: ($N_{LL} \leq 10\%$).
- Standard voltage disturbances.
- Standard operating temperature up to 55°C.
- Normal switching frequency up to 5 000/year.
- Maximum current (including harmonics) is $1.5 \times I_N$.

Technology

Constructed internally with single-phase capacitor elements assembled in an optimized design. Each capacitor element is manufactured with metallized polypropylene film.

The active capacitor elements are covered in a specially formulated biodegradable, non-PCB, polyurethane soft resin. This ensures thermal stability and heat removal from inside the capacitor.

The unique finger-proof CLAMPTITE termination is fully integrated with discharge resistors. It allows suitable access to tightening and cable termination without any loose connections.

For Lower ratings, double fast-on terminals with integrated cables are provided for easy and faster connection, reducing the risk of terminal overheating and failure.

Safety

- Self-healing.
- Pressure-sensitive disconnecter on all the phases.
- Discharge resistors fitted - non removable.
- Finger-proof CLAMPTITE terminals to reduce risk of accidental contact and to ensure firm termination (10 to 30.3 kvar in three phase and 8.3 - 15.1 kvar in single phase).

Easy installation & maintenance

- Optimized design for safety, reliability with required performance, Optimized size to ensure easy installation and upto 20% space saving in cubicles.
- New CLAMPTITE terminals for easy of connection that maintains the terminal tightness with IP20 protection.
- Non accessible in-built discharge resistors to ensure safety.
- Single point/Stud for mounting and earthing.
- Simultaneous and safe disconnection of all the phases at end of life in EasyLogic™.
- Stacked design and resin filled technology for better heat dissipation/cooling.

Benefits

- Easy installation.
- Easy for reliability and safe usage.
- Easy for quality assurance.
- Easy choice for building your solutions with other Schneider Electric components.
- Easy choice for savings.

A

B

C

D

E

F

G

H

I

J

EasyLogic PFC Capacitors

Single Phase & Three Phase

A



B

C

D



E

F

G

H

I

J

General characteristics

Standards	IEC 60831-1/2						
Voltage range	<ul style="list-style-type: none"> ■ 230 V to 525 V in Three Phase ■ 220-440 V in Single Phase 						
Frequency	50 / 60 Hz						
Power range	1 to 30.3 kvar						
Losses (dielectric)	< 0.2 W / kvar						
Losses (total)	< 0.5 W / kvar						
Capacitance tolerance	-5%, +10%						
Voltage test	<table border="0"> <tr> <td>Between terminals</td> <td>2.15 x U_N (AC), 10 s</td> </tr> <tr> <td>Between terminal & container</td> <td>3 kV (AC), 10 s or 3.66 kV (AC), 2 s</td> </tr> <tr> <td>Impulse voltage</td> <td>8 kV</td> </tr> </table>	Between terminals	2.15 x U _N (AC), 10 s	Between terminal & container	3 kV (AC), 10 s or 3.66 kV (AC), 2 s	Impulse voltage	8 kV
Between terminals	2.15 x U _N (AC), 10 s						
Between terminal & container	3 kV (AC), 10 s or 3.66 kV (AC), 2 s						
Impulse voltage	8 kV						
Discharge resistor	Fitted, standard discharge time 60 s						

Working conditions

Ambient temperature	-25 / 55°C (Class D)
Humidity	95%
Altitude	2,000 m above sea level
Overvoltage	1.1 x U _N 8 h in every 24 h
Overcurrent	Up to 1.5 x I _N
Peak inrush current	200 x I _N
Switching operations (max.)	Up to 5,000 switching operations per year
Mean Life expectancy	Up to 100,000 hrs
Harmonic content withstand	N _{LL} ≤ 10%

Installation characteristics

Mounting position	Indoor, upright
Fastening	Threaded M12 stud at the bottom
Earthing	
Terminals	<ul style="list-style-type: none"> ■ CLAMPTITE - terminals with electric shock protection (finger-proof) & double fast-on terminal in lower kvar ■ Stud type terminal: <ul style="list-style-type: none"> □ three way stud type terminals for the ratings above 30.3 kvar in three phase capacitors (2 terminals for single phase) □ two way stud terminals for ratings above 15.1 kvar in single phase

Safety features

Safety	Self-healing + Pressure-sensitive disconnecter + Discharge device
Protection	IP20 (for fast-on and clamtite)

Construction

Casing	Extruded Aluminium Can
Dielectric	Metallized polypropylene film with Zn/Al alloy
Impregnation	Biodegradable, Non-PCB, polyurethane soft resin

Technical characteristics

EasyLogic PFC+ Capacitors

Three Phase

An Easy choice for savings which is optimized to deliver the performance you need. Suitable for operating conditions with a few non-linear loads to deliver safe and reliable performance.



EasyLogic™ three phase



EasyLogic™ single phase

Operating conditions

- For networks with insignificant non-linear loads: ($N_{LL} \leq 15\%$).
- Standard voltage disturbances.
- Standard operating temperature up to 55°C.
- Normal switching frequency up to 6 500/year.
- Maximum current (including harmonics) is $1.6 \times I_N$.

Technology

Constructed internally with single-phase capacitor elements assembled in an optimized design.

Each capacitor element is manufactured with metallized polypropylene film.

The active capacitor elements are covered in a specially formulated biodegradable, non-PCB, polyurethane soft resin. This ensures thermal stability and heat removal from inside the capacitor.

The unique finger proof CLAMPTITE termination is fully integrated with discharge resistors. It allows suitable access to tightening and cable termination without any loose connections.

For Lower ratings, double fast-on terminals with integrated cables are provided for easy and faster connection, reducing the risk of terminal overheating and failure.

Safety

- Self-healing.
- Pressure-sensitive disconnecter on all the phases.
- Discharge resistors fitted - non removable.
- Finger-proof CLAMPTITE terminals to reduce risk of accidental contact and to ensure firm termination (10 to 25 kvar in three phase).
- Stud terminals above than 25 kvar for easy terminal connection.

Easy installation & maintenance

- Optimized design for safety, reliability with required performance, Optimized size to ensure easy installation and upto 20% space saving in cubicles.
- New CLAMPTITE terminals for easy of connection that maintains the terminal tightness with IP20 protection.
- Non accessible in-built discharge resistors to ensure safety.
- Single point/Stud for mounting and earthing.
- Simultaneous and safe disconnection of all the phases at end of life in EasyLogic™.
- Stacked design and resin filled technology for better heat dissipation/cooling.

Benefits

- Easy installation.
- Easy for reliability and safe usage.
- Easy for quality assurance.
- Easy choice for building your solutions with other Schneider Electric components.
- Easy choice for savings.

A

B

C

D

E

F

G

H

I

J

EasyLogic PFC+ Capacitors

Three Phase

A



B

C

D



E

F

G

H

I

J

General characteristics

Standards	IEC 60831-1/2	
Voltage range	480 V to 525 V in Three Phase	
Frequency	50 / 60 Hz	
Power range	7.5 to 45.2 kvar	
Losses (dielectric)	< 0.2 W/kvar	
Losses (total)	< 0.5 W/kvar	
Capacitance tolerance	-5%, +10%	
Voltage test	Between terminals	2.15 x U _N (AC), 10 s
	Between terminal & container	3 kV (AC), 10 s or 3.66 kV (AC), 2 s
	Impulse voltage	8 kV
Discharge resistor	Fitted, standard discharge time 60 s	

Working conditions

Ambient temperature	-25 / 55°C (Class D)
Humidity	95%
Altitude	2,000 m above sea level
Overvoltage	1.1 x U _N 8 h in every 24 h
Overcurrent	Up to 1.6 x I _N
Peak inrush current	200 x I _N
Switching operations (max.)	Up to 6,500 switching operations per year
Mean Life expectancy	Up to 120,000 hrs
Harmonic content withstand	N _{LL} ≤ 15%

Installation characteristics

Mounting position	Indoor, upright
Fastening	Threaded M12 stud at the bottom
Earthing	
Terminals	<ul style="list-style-type: none"> ■ CLAMPTITE - terminals with electric shock protection (finger-proof) & double fast-on terminal in lower kvar ■ Stud type terminal: <ul style="list-style-type: none"> □ three way stud type terminals for the ratings above 25 kvar in three phase capacitors

Safety features

Safety	Self-healing + Pressure-sensitive disconnecter + Discharge device
Protection	IP20 (for fast-on and clamptype)

Construction

Casing	Extruded Aluminium Can
Dielectric	Metallized polypropylene film with Zn/Al alloy
Impregnation	Biodegradable, Non-PCB, polyurethane soft resin



Learn more about EasyLogic PFC Capacitors range here



Offer



Catalogue

Scan or click on QR code

If you need more details about product references and availability, please check your local Schneider Electric contact <https://www.se.com/ww/en/work/support/country-selector/contact-us.jsp>



EasyLogic™ APF

- A
- B
- C
- D
- E
- F
- G
- H
- I
- J



EasyLogic™ APF: Multi-function Active Harmonic Filter Reliable - Scalable - Simple

Power quality problems are one of the major causes of unscheduled downtime, equipment malfunction, and damage. Reliability and consistency of electricity supply are critical to businesses, from industrial plants, medical facilities, data centers to office buildings. When power quality is imperfect due to disturbances such as interruptions, voltage dips or harmonic pollution, your business suffers. It is an area of growing concern for end users due to the frequency of occurrence and financial impact of issues: 30% to 40% of all unscheduled downtime today is related to power quality problems.

High performance, cost-effective solutions for stabilizing electrical networks by providing harmonic mitigation, power factor correction and load balancing.

Applications

 Buildings	 Industry	 Energy
Small & Medium Commercial (non-critical application) <ul style="list-style-type: none"> • Restaurant • Small-Mid Healthcare • Coffee-shop 	Small & Mid-sized industrial site (non-critical application) <ul style="list-style-type: none"> • Water & Wastewater Food • Metal, Minerals & Mining • Food & Beverage 	Low-end (non-critical application) <ul style="list-style-type: none"> • Utilities (Low-end DSO) • Power Generation(Low-end)

Functions

- Phase harmonic correction
- Neutral harmonic correction
- Power Factor Correction (cos ϕ)
- Mains load balancing

Higher air exhaust ingress protection	Cable glands for ease of installation	In-built EMC filter for enhanced safety
		

- A
- B
- C
- D
- E
- F
- G
- H
- I
- J

EasyLogic™ APF

Selection Table and accessories

A

EasyLogic™ APF 208 V 50/60 Hz						
Current Rating (A)	Commercial Reference Number	IP	Mounting Type	Cable Entry	Dimension H x W x D (mm)	Mass (kg)
50	EZAPF05024W20	IP20	wall mount	Top	750 x 507 x 205	41
100	EZAPF10024W20				750 x 507 x 205	41
50	EZAPF05024W31	IP31	wall mount	Side	960 x 600 x 230	45
100	EZAPF10024W31				960 x 600 x 230	45
100	EZAPF10024R20	IP20	rack mount	Rear	200 x 530 x 733	41

B

EasyLogic™ APF 400 V 50/60 Hz						
Current Rating (A)	Commercial Reference Number	IP	Mounting Type	Cable Entry	Dimension H x W x D (mm)	Mass (kg)
50	EZAPF05044W20	IP20	wall mount	Top	620 x 507 x 185	28
100	EZAPF10044W20				750 x 507 x 205	41
150	EZAPF15044W20				805 x 507 x 275	55
50	EZAPF05044W31	IP31	wall mount	Side	835 x 600 x 210	32
100	EZAPF10044W31				960 x 600 x 230	45
150	EZAPF15044W31				1015 x 600 x 300	60
50	EZAPF05044R20	IP20	rack mount	Rear	180 x 530 x 603	28
100	EZAPF10044R20				200 x 530 x 733	41
150	EZAPF15044R20				270 x 530 x 788	55
300	EZAPF30044F20	IP20	floor standing	Top	2000 x 1000 x 600	342
450	EZAPF45044F20					405

C

EasyLogic™ APF 480 V 50/60 Hz						
Current Rating (A)	Commercial Reference Number	IP	Mounting Type	Cable Entry	Dimension H x W x D (mm)	Mass (kg)
50	EZAPF05053W20	IP20	Wall mount	Top	750 x 507 x 205	41
100	EZAPF10053W20				750 x 507 x 205	41
150	EZAPF15053W20				805 x 507 x 275	55
50	EZAPF05053W31	IP31	Wall mount	Side	960 x 600 x 230	45
100	EZAPF10053W31				960 x 600 x 230	45
150	EZAPF15053W31				1015 x 600 x 300	60
100	EZAPF10053R20	IP20	Rack mount	Rear	200 x 530 x 733	41
150	EZAPF15053R20				270 x 530 x 788	55

D

E

F

Accessories

G

EasyLogic™ APF Accessories				
Commercial Reference Number	Description	Mounting unit	Dimension H x W x D (mm)	Mass (kg)
EZAPF070HMI	EasyLogic™ APF 7 inch HMI	For rack-mounted modules or wall-mounted modules connected in parallel	135 x 192 x 71	1.5

H

I

J



Learn more about EasyLogic™ APF range here



Offer



Catalogue

Scan or click on QR code

If you need more details about product references and availability, please check your local Schneider Electric contact <https://www.se.com/ww/en/work/support/country-selector/contact-us.jsp>

- A
- B
- C**
- D
- E
- F
- G
- H
- I
- J



Insulation Monitoring for Ungrounded Networks

The Vigilohm range of insulation monitoring devices (IMDs) provides you with a simple, reliable insulation monitoring, communication and fault location solution for your IT (ungrounded) networks.

This renewed and simplified offer contribute to increasing personnel & equipment safety and process availability. Injection principle

- Measures the resistance of a circuit
- Triggers an alarm in case of an insulation fault, through contact relays, local message and Modbus communication.

Benefits

In low voltage electrical distributions, the combined use of an IT network arrangement and Insulation Monitoring Devices

- Increases personnel safety
- Reduces risk of fire or explosion
- Increases process uptime
- Ease maintenance and reduce OPEX

Key characteristics



- > Fault detection and signaling
- > Insulation resistance value display
- > Earth leakage capacitance display
- > Modbus communication
- > Data log with time-stamped events
- > Voltage adaptor compatibility
- > Advanced transformer monitoring
- > Refer to the Vigilohm catalog for complete feature and specification information on each device in the Vigilohm range.

Standards compliance

Complies with all major standards, IEC, UL, DNV



A

Healthcare



B

Industry



C

Water and Waste Water



D

Infrastructure
and Transportation



E

Utilities



Photovoltaic



F

Marine



Insulation Monitoring
of Off-Line Equipment



G

Harsh Environment



Medium Voltage
Ungrounded Networks



H

I

DC Networks



J

A simple range to meet your needs

Industrial Networks

Monitoring and Control

Power Monitoring & SCADA system

Communication and Simple Monitoring

Gateway, Data logger & Web Server

Insulation Monitoring Devices

Monitoring of the global network insulation

Insulation Fault Locators

Identification of the faulty feeder

Toroids

Used along with the Fault Locators

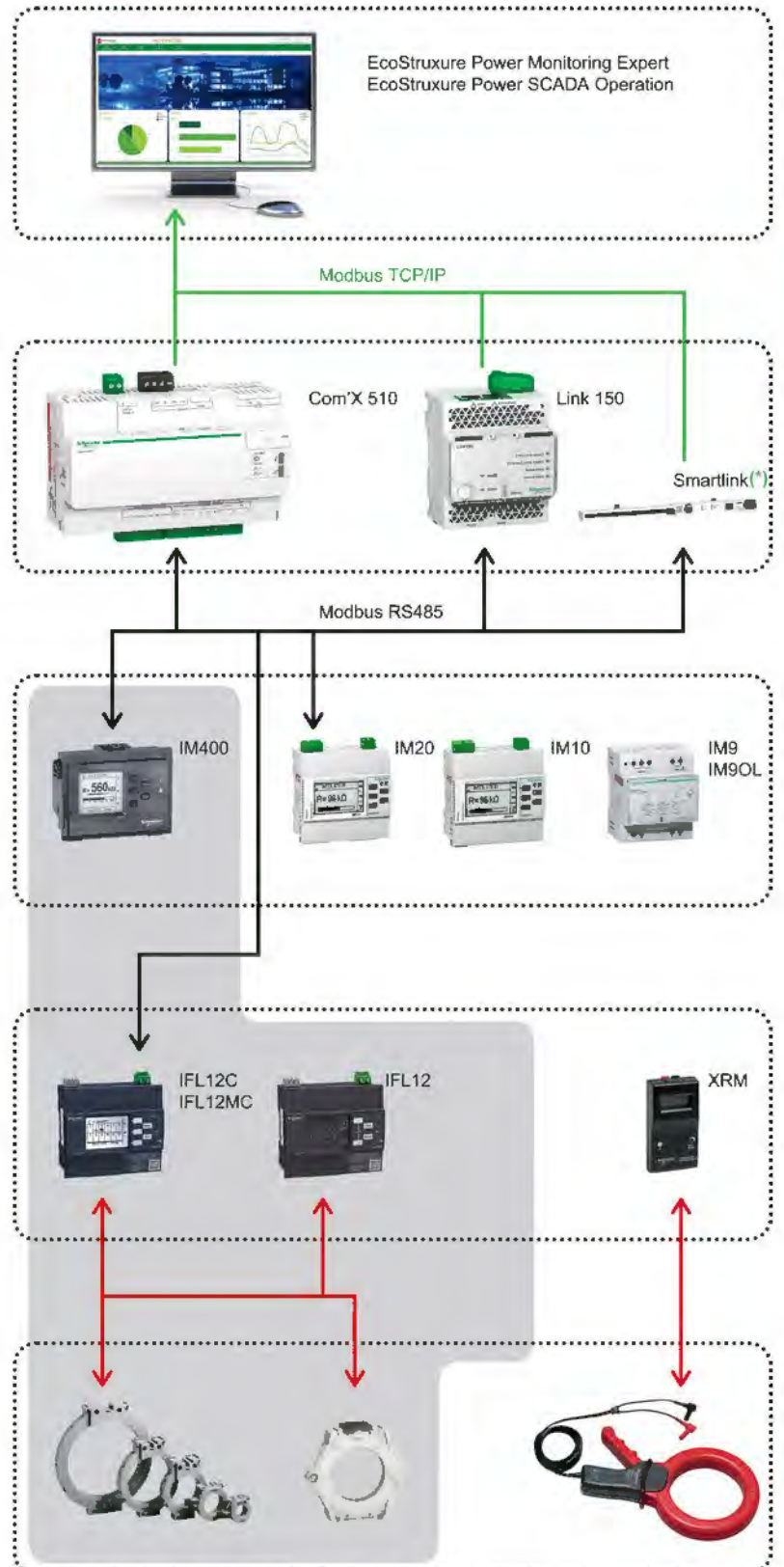

[*] Alarm relay position can be sent to a supervisor via a Smartlink.



- A
- B
- C
- D
- E
- F
- G
- H
- I
- J

Monitoring and Control

Power Monitoring & SCADA system

Communication

Gateway

Local Displays

HMI in the medical room

Insulation Monitoring Devices

Monitoring of the global network insulation

Insulation Fault Locators

Identification of the faulty

Toroids

Used along with the Fault Locators

Dedicated offers for critical rooms compliant with IEC60364-7-710

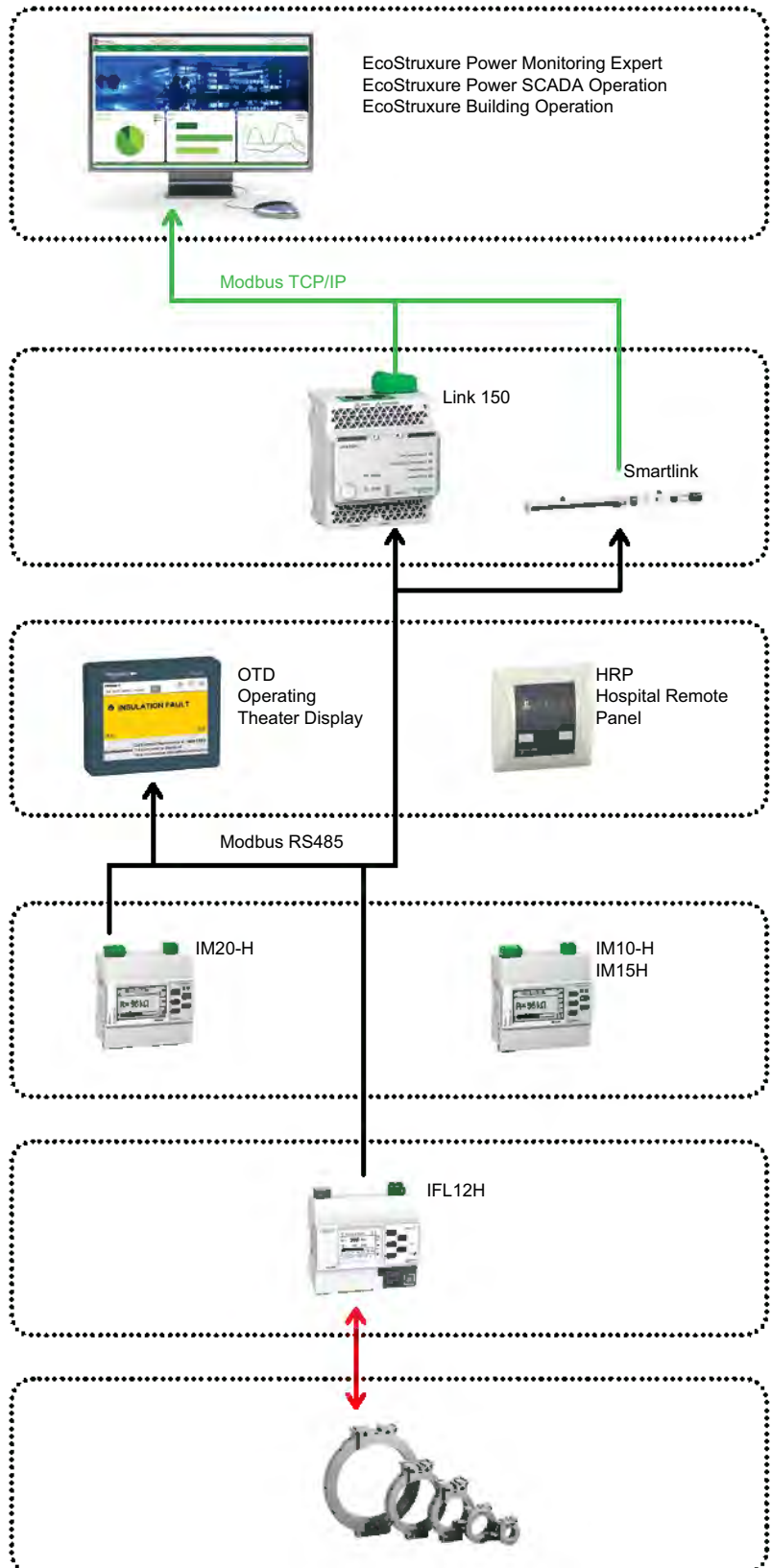

IM Selection Guide	Off-Line Motor	Small AC System	Small & Medium AC / DC System		Large AC/DC System	MV system	Hospital	
								
	IM9-OL	IM9	IM10	IM20	IM400	IM400THR	IM10-H IM15H	IM20-H

Application

Healthcare							<input checked="" type="checkbox"/>	<input checked="" type="checkbox"/>
Harsh environment and Photovoltaic					IM400C			
Standard Applications		<input checked="" type="checkbox"/>	<input checked="" type="checkbox"/>	<input checked="" type="checkbox"/>	<input checked="" type="checkbox"/>			
Off-Line Motor (TT, TN, IT)	<input checked="" type="checkbox"/>							
Medium Voltage								

IT Power System Type

No disturbance system		<input checked="" type="checkbox"/>	<input checked="" type="checkbox"/>	<input checked="" type="checkbox"/>	<input checked="" type="checkbox"/>	<input checked="" type="checkbox"/>		
Low level of disturbance			<input checked="" type="checkbox"/>	<input checked="" type="checkbox"/>	<input checked="" type="checkbox"/>	<input checked="" type="checkbox"/>		
High level of disturbance					<input checked="" type="checkbox"/>	<input checked="" type="checkbox"/>		

Power Supply

24-48V DC					IM400L	IM400LTHR	110-230 V AC 125-250 V DC	
110-440V AC/DC	<input checked="" type="checkbox"/>	<input checked="" type="checkbox"/>	<input checked="" type="checkbox"/>	<input checked="" type="checkbox"/>	<input checked="" type="checkbox"/>	<input checked="" type="checkbox"/>		

Fault Location

Manual fault locator		With XGR	With XGR	With XGR	<input checked="" type="checkbox"/>			
Automatic fault locator					IFL12, IFL12C		IFL12H	
Per feeder: adjustable threshold, measurement, custom name					IFL12MC			

Information and Communication

Preventive Insulation Alarm Output relay	<input checked="" type="checkbox"/>				<input checked="" type="checkbox"/>	<input checked="" type="checkbox"/>		
Insulation Alarm Output Relay	<input checked="" type="checkbox"/>	<input checked="" type="checkbox"/>	<input checked="" type="checkbox"/>	<input checked="" type="checkbox"/>	<input checked="" type="checkbox"/>	<input checked="" type="checkbox"/>	<input checked="" type="checkbox"/>	<input checked="" type="checkbox"/>
Modbus RS485				<input checked="" type="checkbox"/>	<input checked="" type="checkbox"/>	<input checked="" type="checkbox"/>		<input checked="" type="checkbox"/>
Historical data				<input checked="" type="checkbox"/>	<input checked="" type="checkbox"/>	<input checked="" type="checkbox"/>		<input checked="" type="checkbox"/>



IFL Selection Guide



IFL12 IFL12L IFL12C IFL12MC IFL12LMC IFL12LMCT IFL12MCT IFL12H

Application

Healthcare									<input checked="" type="checkbox"/>
Harsh environment						<input checked="" type="checkbox"/>	<input checked="" type="checkbox"/>		
Standard Applications	<input checked="" type="checkbox"/>	<input checked="" type="checkbox"/>	<input checked="" type="checkbox"/>	<input checked="" type="checkbox"/>	<input checked="" type="checkbox"/>				

IT Power System Type

No disturbance system	<input checked="" type="checkbox"/>	<input checked="" type="checkbox"/>	<input checked="" type="checkbox"/>	<input checked="" type="checkbox"/>	<input checked="" type="checkbox"/>	<input checked="" type="checkbox"/>	<input checked="" type="checkbox"/>		
Low level of disturbance	<input checked="" type="checkbox"/>	<input checked="" type="checkbox"/>	<input checked="" type="checkbox"/>	<input checked="" type="checkbox"/>	<input checked="" type="checkbox"/>	<input checked="" type="checkbox"/>	<input checked="" type="checkbox"/>		
High level of disturbance				<input checked="" type="checkbox"/>	<input checked="" type="checkbox"/>	<input checked="" type="checkbox"/>	<input checked="" type="checkbox"/>		

Power Supply

24-48 V DC		<input checked="" type="checkbox"/>			<input checked="" type="checkbox"/>	<input checked="" type="checkbox"/>			110-230 V AC 125-250 V DC
110-440 V AC/DC	<input checked="" type="checkbox"/>		<input checked="" type="checkbox"/>	<input checked="" type="checkbox"/>				<input checked="" type="checkbox"/>	

Information and Communication

Insulation Alarm Output Relay	<input checked="" type="checkbox"/>	<input checked="" type="checkbox"/>	<input checked="" type="checkbox"/>	<input checked="" type="checkbox"/>	<input checked="" type="checkbox"/>	<input checked="" type="checkbox"/>	<input checked="" type="checkbox"/>	<input checked="" type="checkbox"/>	<input checked="" type="checkbox"/>
Modbus RS485			<input checked="" type="checkbox"/>	<input checked="" type="checkbox"/>	<input checked="" type="checkbox"/>	<input checked="" type="checkbox"/>	<input checked="" type="checkbox"/>	<input checked="" type="checkbox"/>	<input checked="" type="checkbox"/>
Historical data				<input checked="" type="checkbox"/>	<input checked="" type="checkbox"/>	<input checked="" type="checkbox"/>	<input checked="" type="checkbox"/>	<input checked="" type="checkbox"/>	<input checked="" type="checkbox"/>

Choosing the Optimal Solution

According to the type of network

- An off-line load: IM9-OL
- A small purely AC network (with no DC component): IM9
- An IT island, AC and/or DC: IM10 or IM20
- A critical room in a healthcare facility: IM10-H, IM15H, IM20-H and IFL12H
- A larger network, or a network requiring automatic fault location: IM400 with IFL12 range
- Networks requiring deeper analysis per feeder: IM400 and IFL12MC.

According to the network constraints

- For large networks, it is recommended to monitor their leakage capacitance (IM20, IM400)
- On highly disturbed networks, with many variable speed drives, it is recommended to select an IM400 for optimal performance
- Depending on the nominal voltage of the network, a voltage adaptor may be required together with the Insulation Monitor, or an IM400THR.



Learn more about
Vigilohm
range here



Offer



Catalogue

Scan or
click on
QR code

If you need more details about product references and availability, please check your local Schneider Electric contact
<https://www.se.com/ww/en/work/support/country-selector/contact-us.jsp>

Motor control

TeSys	
General overview	D-236
Easy TeSys	
General overview	D-242



A

B

C

D

E

F



Innovative and connected solutions for motor starters



G

- > Control
- > Power
- > Protect
- > Active

H

Stay smart with the world's best-selling motor control solutions from the inventor of the world's first contactor - Schneider Electric™.

I

J

For almost a century, TeSys motor controls have driven the industry with innovations in motor protection, monitoring, and control.

It started with the introduction of the industry's first BAR contactor in 1924, and today, the legacy of innovation is built into every **TeSys** motor control device.

Best-in-class safety and reliability, plug-and-play architecture, and flexible functionality mean TeSys motor control solutions can meet your requirements across a wide range of applications, from the most common to the most advanced.

Wherever you are and anywhere your projects come together, you can trust Schneider Electric and TeSys contactors, circuit breakers, relays, and switches for unmatched reliability, complete compatibility with international standards, and the robust support of the Schneider Electric global supply network.



Start smart. Run smart.
With TeSys motor controls.

A Century of Innovation and Leadership

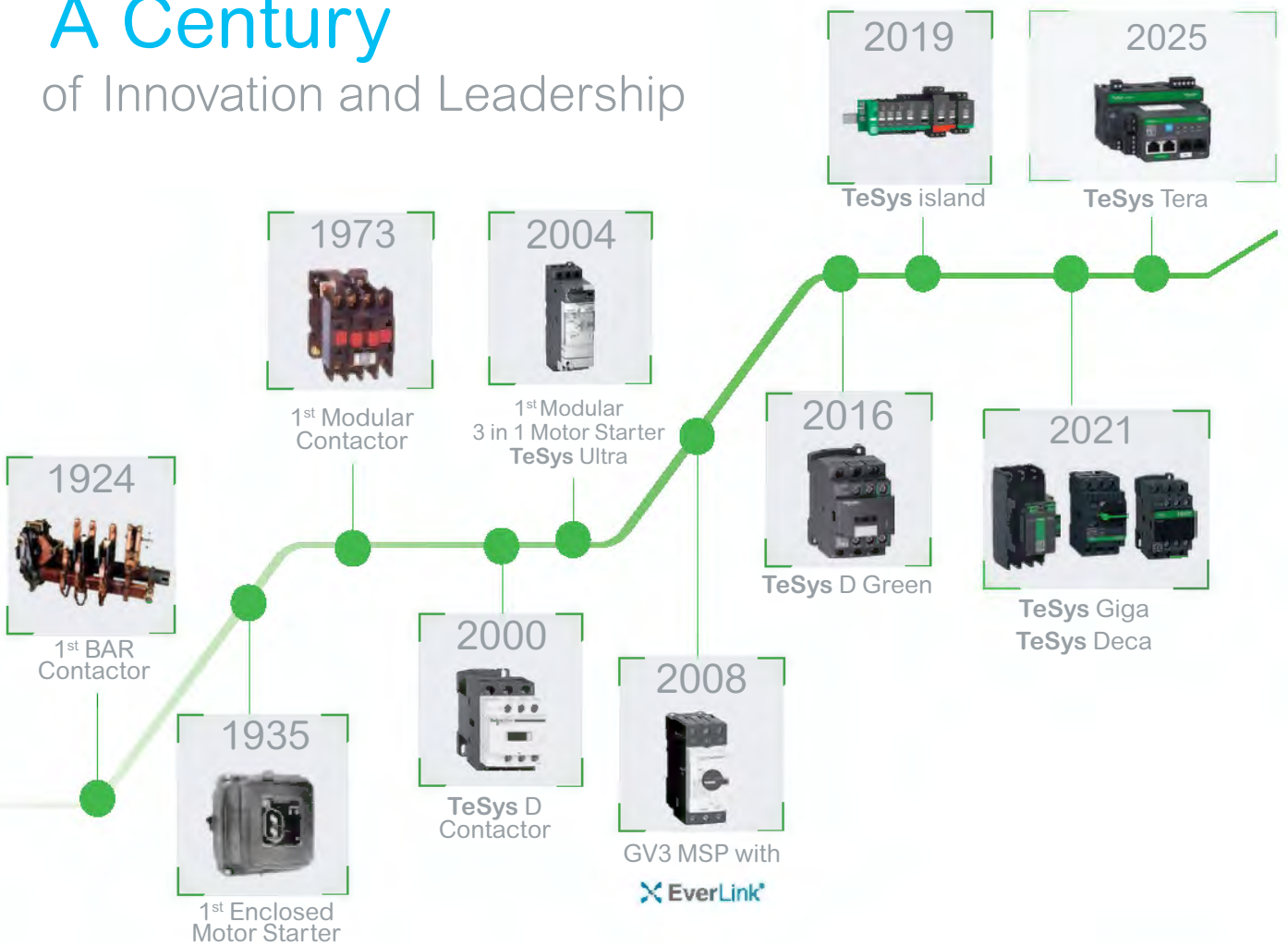

TeSys

A

Superior safety for all industries

TeSys motor controls come with all of the isolation, protection and emergency handling you need to comply with international codes. High-contrast covers identify safety-critical devices to prevent inadvertent manual operation. Every TeSys contactor is both mechanically linked and equipped with mirror contacts for safety applications and wherever auxiliary contact state reliability is critical.

B



HVAC

Ensure 24/7 availability of your HVAC system with reliable products that can reach high ambient temperatures without derating.



Conveying

Decentralize the control cabinet of your conveyor line and benefit from up to 80% space reduction.



Genset

Make certain your generator starts even in the harshest conditions with robust TeSys solutions.



Pumping

Optimize single or multi-drive boosters for industry or infrastructure with energy and cost-effective solutions.

D

E



Packaging

Keep pace with the most demanding, high-end packing applications with solutions that can perform 30 million AC53a electrical cycles, like TeSys H.



Oil and Gas

Keep your employees and assets safe and improve uptime in onshore and offshore applications: pipeline operations: LNG and natural gas processing: and refining and petrochemical applications.



Water and Wastewater

Optimize the treatment and delivery of safer water by reducing energy usage and lowering operating costs.



Food and Beverage

Serve your customers with environmentally friendly products to improve sustainability, efficiency, and flexibility, allowing you to adapt to changing customer habits.

F

G

H

Online selection tool

EcoStruxure™ Motor Control Configurator

For Direct-On-Line and Star-Delta starters, motor circuit breakers with advanced protection, motor management relays, configurations for total coordination, drives, and soft starters.

No matter what kind of starting method you need, our online **EcoStruxure™ Motor Control Starter Configurator** will help you to quickly and easily select the optimal combination of components to ensure maximized motor safety, protection, and uptime.



Scan or click on QR code

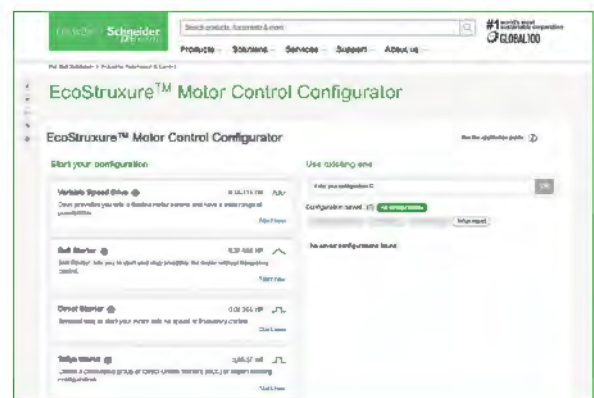

NEW Visual aspect

The first evolution concerns the products, it will bring a **Premium design** to your control panels thanks to the main TeSys components that now present the **same visual homogeneity**.

- The structuring of **the components naming** is the second point of evolution, it answers the need to classify the products by function and by range in the selection tools, the catalog and the Schneider Electric website (www.se.com).
- The last new feature is the presence of **a product reference table at the end of the commercial part of each chapter** (before the information for designers). It allows you to quickly check the availability of a product variant and access its technical data sheet online.

The design of the TeSys core offer is evolving. Circuit breakers, contactors and several other components are now sharing a modern look giving the control panel a new and qualitative visual aspect.

Schneider Electric's identity is fully revealed by the green parts.



NEW TeSys function names

TeSys components are grouped by function name, for easier identification. These functions are related to motor, power, control and protection.

> TeSys Power:

Components for powering motors



> TeSys Control:

Components for controlling motors



> TeSys Protect:

Components for protecting motors



TeSys Active gathers the devices providing built-in communication with motor monitoring and control functions.

> TeSys Active:

Connected components for motor circuits



- A
- B
- C
- D
- E
- F
- G
- H
- I
- J

TeSys

A

NEW TeSys component series names

- Series names group conventional components (circuit breakers, contactors, relays, overcurrent relays) by current rating ranges.
 - 0 to 16 A > **TeSys K Series**
 - 9 to 150 A > **TeSys "Deca" Series**
 - 115 to 800 A > **TeSys "Giga" Series**.
- TeSys advanced components have a specific classification.
 - 0 to 38 A All-in-one starters > **TeSys "Ultra" Series**
 - 0 to 80 A Motor Control/Protection/Monitoring system > **TeSys "island" Series**.
- Other TeSys component names remain unchanged (TeSys F, TeSys B, TeSys T).

B

C

D

NEW TeSys components full names at a glance

Old names	NEW names	Complementary indications
	TeSys Function - Component Series	
TeSys Vario, mini Vario	TeSys Control - Switch-disconnectors	
TeSys DF	TeSys Power - Fuse carriers	DF type
TeSys GS	TeSys Power - Switch-disconnector fuses	1 - 30 kvar
<ul style="list-style-type: none"> ■ TeSys GV2 ■ TeSys GV3 ■ TeSys GV4 	TeSys Power - Deca circuit breakers	<ul style="list-style-type: none"> ■ Frame 2 ■ Frame 3 ■ Frame 4
<ul style="list-style-type: none"> ■ TeSys GV5 ■ TeSys GV6 	TeSys Power - Giga circuit breakers	<ul style="list-style-type: none"> ■ Frame 5 ■ Frame 6
TeSys D	<ul style="list-style-type: none"> ■ TeSys Control - Deca control relays ■ TeSys Control - Deca contactors 	
TeSys LRD, LR9D	TeSys Protect - Deca overload relays	
TeSys H	TeSys Control - Hybrid motor starters	
TeSys U	TeSys Control - Ultra motor starters	
TeSys island	TeSys Active - island motor starter	

E

F

G

H

I

J



Learn more about TeSys range here



Offer



Catalogue

Scan or click on QR code

If you need more details about product references and availability, please check your local Schneider Electric contact <https://www.se.com/ww/en/work/support/country-selector/contact-us.jsp>



A

B

C

D

E

F

G

H

I

J



100 years of leadership in motor starter technology

Easy TeSys provides you **Essential** control and protection for your applications.



 HVAC



 GenSet



 Pumps



 Textile



 Material Handling



 Packaging

Two principles to build your starter solution

2-components solution (Thermal-magnetic circuit breaker + Contactor)

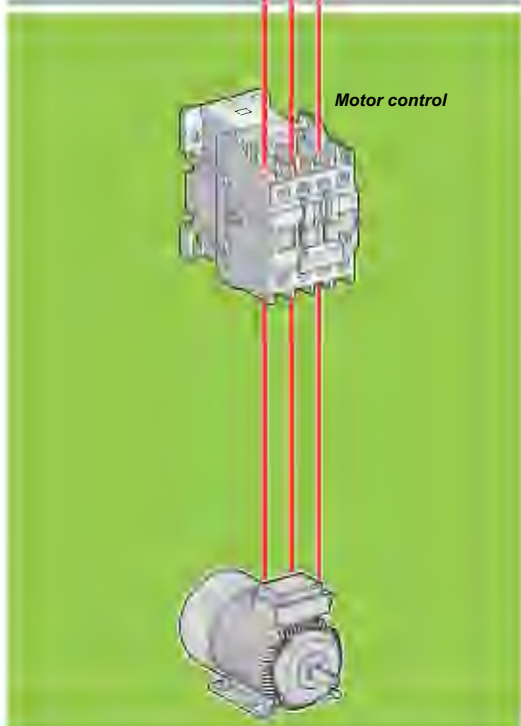
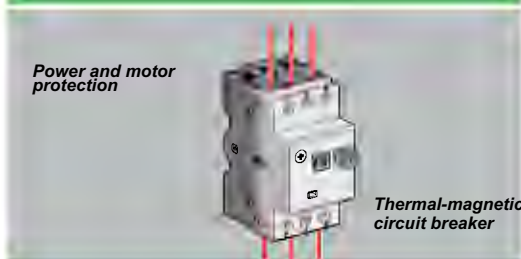

3-components solution (Magnetic circuit breaker or fuse + Contactor + TOR)

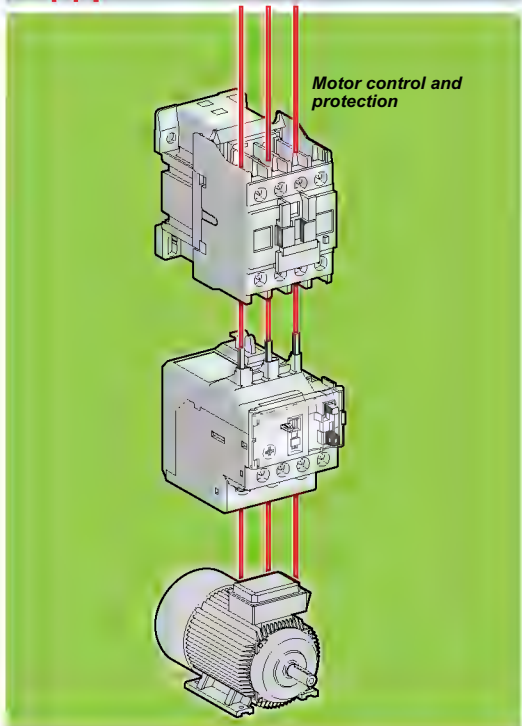
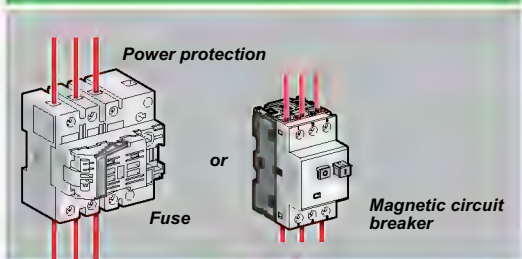

To build the essential solutions in an easy and simple way

Control

Reverser starter

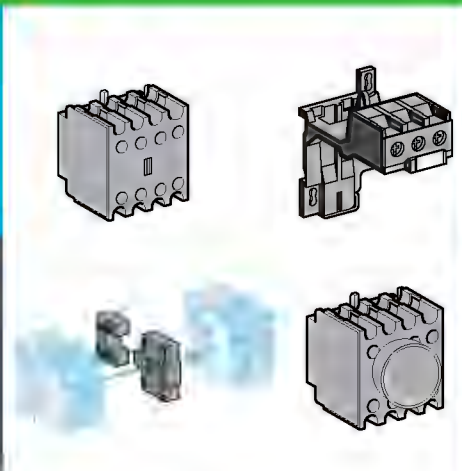

Terminal block

Star-Delta solution

Designed for the essential

- A
- B
- C
- D**
- E
- F
- G
- H
- I
- J

General overview

Easy TeSys

Easy TeSys Control - contactors

Easy TeSys contactors are available up to 32 A, 20 HP/480 V AC, suitable for light duty applications

- Balance of performance and budget with no quality compromise
- DIN rail and panel mount option
- Direct mount overload relay to contactor
- Busbar and electrical contactor connector for manual motor controllers
- Short-circuit current ratings up to 35 kA with breakers.

Benefits

- Simple to select and install at optimized budget
- Reduced installation time
- Robust performance for common applications
- Flexibility to add motor disconnects to help meet NEC requirements

Applications

For use on conveyors, packaging, pumps, compressors, HVAC, refrigeration, furnace applications and more! Easy TeSys contactors are ideal for these types of applications with power ratings and operational life of approximately 1 million electrical operations.



Easy TeSys Control - Control relays

Control relays with three combination of contact types: 2NO/2NC, 3NO/1NC, 4NO/0NC

Benefits

- Designed to perform the essential motor starter and switching functions
- Easy choice for simplicity and flexibility
- Easy to install, easy to order, easy to understand

Applications

Simple machines for: HVAC, Pumps, Telecom, GenSet, Textile, Packaging, Conveyor and more.



Easy TeSys Protect

Easy TeSys thermal overload relays up to 32 A, designed for Easy TeSys contactors ranges, are suitable for essential protection.

- Balance of performance and budget with no quality compromise
- Direct mount to DPE contactor
- Panel/DIN rail mount with adapter
- Short-circuit current ratings up to 35 kA with breakers

An easy solution for OEM's, panel builders, contractors and system integrators who have a need for motor control, resistive load switching, and isolation applications

UL/CSA approved rated with an overload range of 0.1 to 32 amps. For use with Easy TeSys DPE contactors or as stand alone.

Benefits

- Simple to select and install at an optimized budget
- Reduced installation time
- Robust performance for common applications

Applications

For use on conveyors, packaging, pumps, compressors, HVAC, refrigeration, furnace applications, and more.

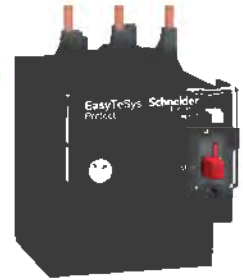

A

B

C

D

E

F

G

H

I

J

Easy TeSys

Easy TeSys Power

Easy TeSys Manual motor controller provides essential manual isolation, manual control, and thermal protection for motors up to 20 HP/480 V AC. Easy TeSys includes 3-pole thermal-magnetic manual motor starters UL 60947-4-1 and are rated "suitable as motor disconnect."

Easy TeSys manual motor controllers are designed to control and protect motors.

An easy solution for OEM's, panel builders, contractors, and system integrators who have a need for motor control, resistive load switching, and isolation applications.



Benefits

Connection

These circuit-breakers are designed for connection by screw clamp terminals. This technique ensures secure, permanent and durable clamping that is resistant to harsh environments, vibration and impact and is even more effective when conductors without cable ends are used. Each connection can take two independent conductors.

Push button control

Operation is controlled manually by operating the Start button "I" 1. De-energization is controlled manually by operating the Stop button "O" 2, or automatically by the thermal-magnetic protection elements.

Protection of motors

- Motor protection is provided by the thermal-magnetic protection elements incorporated in the manual motor starter.
- The magnetic elements (short-circuit protection) have a non-adjustable tripping threshold, which is equal to about 13 times the maximum setting current of the thermal trips.
- The thermal elements (overload protection) include automatic compensation for ambient temperature variations.

Applications

Motor control & protection, resistive load switching, and isolation applications. For use on conveyors, packaging, pumps, compressors, HVAC, refrigeration, furnace applications, and more.

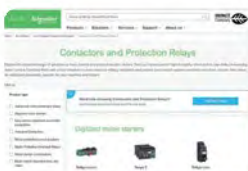

Learn more about
Easy TeSys
range here



Offer



Catalogue

Scan or
click on
QR code

If you need more details about product references and availability, please check your local Schneider Electric contact <https://www.se.com/ww/en/work/support/country-selector/contact-us.jsp>

Variable speed drives and soft starters

Altivar variable speed drives and soft starters

Altivar 12	E-250
Altivar ATV320	E-253
Altivar ATV340	E-256
Altivar 212	E-262
Altivar ATV600	E-268
Altivar ATV900	E-272
Altivar Soft Starter ATS480	E-276
Altistart 22	E-279
Altistart 01	E-280
Selection guide	E-282
Useful links	E-284

E

Altivar variable speed drives and soft starters

- A
- B
- C
- D
- E**
- F
- G
- H
- I
- J



Discover Altivar variable speed drives and soft starters

Improve your energy efficiency and sustainability with Altivar variable speed drives and soft starters. Manage motor control applications up to 20 MW with products ranging from compact products to custom-engineered solutions. Our connected devices offer built-in intelligence to improve operational efficiency, reliability, and safety in various areas, such as industrial processes, machines, or buildings.

Altivar Machine

Drives for efficiency, safety, reliability

Altivar Machine provides the most advanced automation solutions while optimising design and reducing engineering costs for original equipment manufacturers (OEMs).

Altivar 12

Variable speed drives for small machines with three-phase 240 V 0.18 to 4 kW asynchronous motor



Altivar ATV320

Smart variable speed drives from 0.18 to 15 kW (0.25 to 20 Hp)



Altivar ATV340

IoT-ready variable speed drives for safety and heavy duty applications from 0.75 to 75 kW (1 to 100 Hp)



Altivar variable speed drives and soft starters

Altivar Building

Connected drives for HVAC and pumping

Efficient, compact, and connected product for buildings that's easy to integrate with your building management system (BMS).

Altivar 212

Altivar 212 is a variable speed drives for 3-phase asynchronous motors from 0.75 kW to 75 kW.



Altivar Process

Services-oriented connected drives for industry and utilities

Smart, connected drives from 0.75 kW to 20 MW in low and medium voltage, with embedded services to help you optimise your business through process optimisation, energy management improvements and asset management.

Altivar ATV600

Variable speed drives with embedded Services dedicated to process Industry and Utilities for 3 phases synchronous, asynchronous and special motors from 0,75 kW to 2,6 MW.



Altivar ATV900

Variable speed drives for demanding applications dedicated to maximum productivity with excellent motor control and connectivity capabilities from 0.75 kW to 2,6 MW.



Altivar Soft Starters

Reliable, compact, robust soft starters

Open and easy to integrate into your installation, **Altivar** Soft Starters is a wide and consistent line of soft starters from 0.37 to 900 kW that make your machines last longer.

Altivar Soft Starter ATS480

Soft starters for Process & Infrastructures from 3 to 900 kW. The Altivar™ Soft Starter ATS480 is the next evolution of soft starters for digitization optimized to meet cybersecurity standard. Designed to address process and infrastructures, ATS480 simplifies project execution and maximizes the availability of your applications, even in the most demanding environments. ATS480 builds on the proven robustness and start/stop performance extending the lifetime of the ATS48 equipment and preserving your initial investment by reusing current design.



Altistart 22

Soft starters for pumps and fans from 4 kW to 400 kW and 3-phase asynchronous motors.



Altistart 01

Soft start units and soft start - soft stop units for single phase or 3-phase asynchronous motors from 0,37 to 75 kW.



General overview

Altivar Machine

Altivar 12

Designing technology that frees you from technical tasks

With the Altivar 12, you get greater reliability and simplicity of operation and save even more time for all your applications.

- The smallest drive with integrated EMC for compact machines
- Ever more intuitive and user-friendly programming and menus
- Can be configured in complete safety with the power off, even in its packaging
- A design that can withstand even the harshest environments
- Quick and simple to set up
- With no compromise on quality, and components designed to last 10 years



+ Small

- > The small format and advanced functions of the Altivar 12 mean that it can easily replace any existing drive in its category.

+ Economical

- > **Design:** Save time by using the SoMove software workshop
- > **Commissioning:** Quicker configuration with the power off download function
- > **Wiring and mounting:** Quicker and easier installation with integrated Modbus communication.

+ Ecological

- > An average of 30% energy savings (with the Pump/Fan control profile) for the majority of applications
- > Less cardboard to be recycled - only one box is used for bulk orders.

Collaborative design

We surveyed our customers and users to determine their needs.

The result is the innovative Altivar 12.

Sturdy

- New generation long-life components (10-year service life under normal operating conditions)
- Cards are coated as standard and resistance to disturbed power supplies has been increased to withstand harsh environments

Easy to identify

- All the identification markings on the product are on a hinged door on the front panel
- Easy identification of the connections

Make the most of our energy and resources

Choose peace of mind

The Altivar 12 integrates as standard all the technologies that will make you forget it is there. Its design and choice of components make the Altivar 12 an extremely efficient, reliable and durable drive.

No compromise on quality

- Ever higher performance for your motors assured by:
 - The factory settings, which provide a high quality drive from the very first time the power is turned on
 - The integration of Standard (U/f), Performance (sensorless flux vector control, or SVC) and Pump/Fan (quadratic profile Kn^2) control profiles
 - High dynamic performance on acceleration as well as on braking
 - Excellent speed regulation on machine load surges
- Reduced noise and maintenance:
 - No fan on models up to 0.75 kW at 240 V
 - Cassette type fan, operates automatically on detection of specific temperature setting
- Designed for easy fitting and wiring of the drive:
 - A single tool
 - Power terminals not tightened, ready for wiring
 - Easy access angles
 - Numerous, easy to identify markings
- Fast detection and protection against the motor current peaks associated with certain applications (motor switching, catching on the fly, etc.)
- Perfect integration of single-phase 240 V model into the electrical network thanks to its built-in EMC filter

Communicate intuitively with all your applications

The Altivar 12 is immediately operational. It is configured using the notched wheel or from the SoMove software workshop. The file that is generated can be downloaded to the product even while it is still in its packaging, using the Multi-Loader console. You save commissioning time so that you can spend more time doing your job.

Save time on programming

- A navigation button for easy menu access: you can set the parameters of your application with just a few clicks
- A three-level tree structure
 - Reference Mode: In local operation (On/Off buttons) and for speed adjustment and display
 - Monitoring Mode: For displaying parameters
 - Configuration Mode: For configuring your applications and settings.

Fast

With the Multi-Loader console you can configure 10 drives in their packaging is less than 5 minutes, with no power supply!

Versatile

The Altivar 12 range is designed for 120 to 240 V power supplies.

For your productivity requirements in the most varied applications, see the complete Altivar® range on our website: www.se.com



Altivar Machine

Altivar 12

IP20 or IP21 variable speed drives for asynchronous and synchronous motors

A

B

C

D

E

F

G

H

I

J

Type of machine		Simple machines
		
		Altivar 12
Characteristics		
Power range for 50...60 Hz (kW/HP) line supply		0.18...4/0.25...5
	Single-phase 100...120 V (kW/HP)	0.18...0.75/0.25...1
	Single-phase 200...240 V (kW/HP)	0.18...2.2/0.25...3
	Three-phase 200...230 V (kW/HP)	–
	Three-phase 200...240 V (kW/HP)	0.18...4/0.25...5
	Three-phase 380...480 V (kW/HP)	–
	Three-phase 380...500 V (kW/HP)	–
	Three-phase 500...600 V (kW/HP)	–
	Three-phase 525...600 V (kW/HP)	–
	Three-phase 500...690 V (kW/HP)	–
Degree of protection		IP20
Type of cooling ^[2]		Heatsink or base plate
Drive		0.1...400 Hz
	Output frequency	0.1...400 Hz
	Type of control	Asynchronous motor
		<ul style="list-style-type: none"> ■ Standard (voltage/frequency) ■ Performance (sensorless flux vector control) ■ Pump/fan (Kn2 quadratic ratio)
		Synchronous motor
		–
	Transient overtorque	150...170% of the nominal motor torque
Functions		
Number of functions		40
Number of preset speeds		8
Number of I/O	Analog inputs	1
	Logic inputs	4
	Analog outputs	1
	Logic outputs	1
	Relay outputs	1
Communication	Integrated	Modbus
	Available as an option	–
Cards (available as an option)		–
Dialogue tools		IP54 or IP65 remote terminal
Configuration tools	Setup software	SoMove
	Configuration tools	Simple Loader, Multi-Loader
Standards and certifications		<ul style="list-style-type: none"> ■ IEC 61800-5-1 ■ IEC 61800-3 (environments 1 and 2, categories C1 to C3, cat. C1 with option for ATV 212) CE, UL, CSA, C-Tick, NOM, GOST
References		ATV 12

[1] Heating, Ventilation and Air Conditioning.

[2] The type of cooling depends on the model.

General overview

Altivar Machine

Altivar ATV320

Presentation - ATV320 IP20 Product

The Altivar Machine ATV320 IP20 product is a variable speed drive for three-phase asynchronous and synchronous motors from 0.18 to 15 kW.

The Altivar Machine ATV320 drive is robust, simple to commission, and easy to integrate into different machine layouts and cabinets. It can also be integrated into commonly used automation architectures. Altivar Machine ATV320 variable speed drives are particularly suitable for applications involving simple industrial machines.

Furthermore, Altivar Machine ATV320 embeds many practical functions so that advanced application requirements can be covered. Altivar Machine ATV320 is designed to improve machine performance and increase machine availability while reducing the total machine cost.



Flexible

There are 2 different formats for IP20 products, book and compact:

- The book format (1), 45 and 60 mm (1.77 and 2.63 in.) wide, is designed to be mounted side-by-side to save significant space on the installation foot print.
- The compact format, 72 to 180 mm (2.83 to 7.08 in.) wide, is designed to be integrated in compact electrical cabinets (200 mm (7.87 in.) cabinet depth or less) or mounted directly on the machine frame.



Advanced connectivity

Advanced connectivity allows the Altivar Machine ATV320 to operate in commonly used automation architectures; CANopen and Modbus RTU communication protocols are embedded and various communication fieldbus options are offered based on:

- Modbus TCP, EtherNet/IP, PROFINET, EtherCAT, POWERLINK
- Modbus serial link, CANopen, ProfibusDP, DeviceNet.



Robust design

Altivar Machine ATV320 variable speed drives can operate in harsh environment conditions:

- Up to 50 °C/122 °F without derating
- Up to 60 °C/140 °F with derating without the need for an additional fan
- The printed circuit boards are coated according to IEC 60721-3-3 class 3C3 for industrial environments and 3S2 for solid particles.



Effective motor control

Control of both asynchronous and synchronous motors is both simple and effective. Altivar Machine ATV320 offers +/- 10% accuracy of motor slip in open-loop control with asynchronous motors.

Functions dedicated to synchronous motors

Altivar Machine ATV320 variable speed drives integrate new functions for synchronous motors that are suitable for the majority of commercially-available motors.

- Simplified setting due to the reduced number of configuration parameters (4 maximum)
- Autotuning of the drive/motor combination
- High-frequency injection for high performance in open-loop mode

As standard, Altivar Machine ATV320 drives support to drive synchronous motor in open loop control. This motor control law could help customer to reduce energy consumption.

Each ATV320 drive has a corresponding synchronous motor pre-selected in the SoMove software. User could select and order synchronous motor from the software easily and reduce time to design.



General overview

Altivar Machine

Altivar ATV320

Advanced Variable Speed drive solution

The Altivar Machine ATV320 provides IP20 and IP6x variable speed drive for three-phase synchronous and asynchronous motors in open loop control, and incorporates functions suitable for the most common applications, including:

- Torque and speed accuracy at very low speed, high dynamic performance with flux vector control without sensor.
- Extended frequency range for high-speed motors.
- Parallel connection of motors and special drives using voltage/frequency ratio.
- Static speed accuracy and energy saving for open-loop synchronous motors.

The Altivar Machine ATV320 series focus on easy integration for simple and advanced machine requirements with proven motor control and connectivity.

It offers enhanced automation capabilities and performance for industrial machine applications:

- Effective control of asynchronous and permanent magnet motors
- Complete integration into any system architecture (Ethernet, CANopen, Profibus, etc.)
- Compact and book format for integration in a variety of different cabinet types
- Integrated safety function for compliance with functional safety standards
- Enhanced resistance to polluted atmospheres.

By taking account of constraints on product setup and use right from the design stage, Schneider Electric simplifies the integration of the Altivar Machine ATV320 drive into industrial machines. It features more than 150 functions. It is robust, easy to install, and compliant with the Machinery Directive 2006/42/EC.

ATV320 is fully integrated inside Schneider Electric's EcoStruxure Machine through DTM. PLCopen-compliant libraries. EcoStruxure Machine can be used to develop, configure, and set up an entire machine in a single software environment. Using FDT/DTM technology, it is possible to configure, control, and diagnose Altivar Machine ATV320 drives directly in SoMachine and SoMove software by means of the same software brick (DTM).

With seamless integration under this platform, Altivar Machine ATV320 benefits from the advantage of shorter engineering and design times. Optional Ethernet-based communication capability makes it accessible to production data at any level of automation system.

Applications

Altivar Machine ATV320 drives incorporate functions suitable for the most common applications, including:

- Material handling
- Packaging machines
- Textile
- General machine control.
- Hoisting
- Material working
- Pumping



Material handling application



Packing and packaging machines



Textile application



Hoisting application



Material working application



Pumping

Application segments	
General	Material handling, packaging, textiles, hoisting, mechanical actuators, material working
Specific	Conveyors, carton packers, gantry cranes, woodworking, metal processing, fans, etc.



ATV320

Characteristics			
Degree of protection		IP20	
Power range for 50..60 Hz supply	Single-phase 200...240V	0.18...2.2 kW/0.25... 3 HP	
	Three-phase 200...240V	0.18...15 kW/0.25...20 HP	
	Three-phase 380...500V	0.37...4 kW/0.5...5 HP	
	Three-phase 525...600V	0.75...15 kW/1...20 HP	
Drive	Output frequency	0.1...599 Hz	
	Control type	Asynchronous motor	U/F ratio (2 points, 5 points, energy saving, quadratic), Flux vector control without sensor (Standard and Energy saving)
		Synchronous motor	Vector control without sensor
	Motor sensor	Integrated	-
		As an option	RS422 (speed monitoring)
Overload torque performance		Up to 200% Tn of over torque, and 170% tn of braking torque for open loop motor control	

Functions		
Advanced functions	<ul style="list-style-type: none"> ■ Control of asynchronous and synchronous motors; including IE2, IE3 and PM motors in open loop ■ MachineStruxure integration in SoMachine ■ Operation in Velocity mode and Torque control (with current limitation) ■ Customizable and flexible application functions with ATV Logic (up to 50 function blocks) ■ Numerous application functions for targeted application segments ■ Embedded safety functions dedicated to targeted application segments 	
	Integrated safety functions	STO (up to SIL3 / PLe), SS1, SLS, SMS, GDL
	Number of preset speeds	16
Number of integrated I/O	Analog inputs	3: 1 Bipolar differential ±10 V, 1 with Voltage 0...10 V and 1 with current (0-20 mA)
	Digital inputs	6: 4 configurable (positive or negative logic), 1 with PTC probe input, 1x20 kHz pulse input
	Analog outputs	1: Configurable as voltage (0...10 V) or current (0-20 mA)
	Digital outputs	1: Configurable as sink or source
	Relay outputs	2: 1 with NO/NC contacts and 1 with NO contacts
	Safety function inputs	1 + 4: 1 with STO and 4 configurable for safety functions from digital inputs
Communication	Integrated	Single port compatible with CANopen and Modbus Serial line
	Optional	Ethernet IP and Modbus TCP, CANopen RJ45 Daisy Chain, Sub-D, and screw terminals, PROFINET, Profibus DP V1, EtherCAT, DeviceNet and PowerLink
Configuration and runtime tools		Integrated Display, DTM (Device Type Manager), SoMove software, simple loader (optional), Multiloader (optional), and remote graphic terminal (optional)
Standards and certifications		EN 61800-5-1, EN 61800-3 (Environments 1 and 2, category C2, C3), EN 61800-5-2 up to SIL3 level, EN ISO 13849-1 up to PLe level, EN ISO 13849-2, EN 62061, EN 50495, EN 61800-9-2, EN IEC 63000, CSA 22.2N274, EN 61000-3-2, CSA 22N4 (ATV320●●●●●B) CE, UKCA, ATEX, UL 508C, UL61800-5-1, CSA 22.2 N274, GOST, EAC, CTICK, SIL, NOM (ATV320●●●●●B), KC (ATV320●●●●●B, ATV320●●●●●C)
References		ATV320●●●●●C ATV320●●●●●B

General overview

Altivar Machine

Altivar ATV340

Next level of automation performance

Altivar Machine drives offer extensive flexibility in machine applications. Depending on customer requirements, Ethernet embedded drives are available up to 75 kW and Modular and Sercos drives are available up to 22 kW.



Latest innovations with up-to-date technology

- Modular drives from 0.75 kW to 22 kW/ 1HP to 30 HP
- Ethernet drives from 0.75 kW to 75 kW/ 1HP to 100 HP
- Sercos drives from 0.75 kW to 22 kW/ 1HP to 30 HP

Advanced machine performance

Powerful dynamism and scalability

Altivar Machine ATV340 is a powerful drive that aims to match your machine's motor capabilities with maximum torque and speed performance. With an optimized speed bandwidth up to 400 Hz, the Altivar Machine ATV340 is designed for dynamic applications that may require faster acceleration or settling time.

- Robust enough to withstand high overloads, adaptable to the needs of demanding applications, it can provide up to 220% nominal torque for 2 s.
- Compatible with a wide range of motors, including asynchronous (IE2, IE3) motors, synchronous motors, and reluctance motors for various applications in closed^[1] and open loop, to provide the adaptability and scalability your machine requires.
- Combination of ATV340 minimum application reaction time (1 ms task cycle) and Ethernet or Sercos connectivity, maximizing your machine throughput.

220 %

Nominal torque for 2 s

1 ms

Application cycle time

Reduced machine design time

Altivar Machine ATV340 drives will help reduce your engineering time at every stage of the process to speed up machine activation and operation.

Simplified machine engineering

Altivar Machine ATV340 accommodates numerous functions and features to simplify machine design and reduces the engineering time from selection to commissioning.

- A wealth of interfaces, numerous I/O, multi-Ethernet protocol, Sercos protocol, PTI/PTO, embedded encoders and multiple option interfaces offer maximum flexibility in architecture design.
- Simple master/slave configuration, integrated application functions facilitate and fulfill application performance for hoisting, material handling, material working, and packaging machine segments.



Reduced machine design time helps increase operation efficiency

[1] Not supported by Sercos drives.

General overview

Altivar Machine

Altivar ATV340



Sustained machine operation

Robust design for long-lasting operation and reliable service

ATV340 has been designed to meet the needs of applications for harsh environments such as vibration, shock and non-conductive dust, and where high temperature resistance up to 60 °C/140 °F is needed.



Achilles™ Level 2 certified

Help to protect people and assets while providing continuity of service

Compliant with machine safety and cybersecurity standards, Altivar Machine ATV340 drives offer an embedded solution that can form part of your enduring protection system for your people and assets.

- Compliant with machine-related safety standards EN ISO 13849-1 and EN 62061
- Achilles Level 2 certification against cyber attacks



Cybersecurity for your assets

Fast machine recovery

The Altivar Machine 340 keeps your machine up and running with minimal downtime due to features that include:

- Fast Device Replacement (FDR) service: With the MachineStruxure architecture in place, device replacement takes just two simple steps by the service technician. Firstly, the pluggable connectors mean a new drive can be fitted in less than 3 minutes, then the drive configuration can be downloaded from the PLC in a single action.
- Data logging and monitoring by the local system or remote monitoring via the embedded Web server give users access to any motor or application-relevant data anytime, anywhere. This information can be used for predictive maintenance and to avoid breakdowns.

Communication protocol efficiency

Smart design makes the Modicon M262 the IIoT- ready controller for Logic and Motion machines.

- It offers a real-time automation fieldbus with Sercos for fast motion control, Safety functions, and openness to other devices.
- One cable simplifies the architecture and fieldbus wiring, allowing EtherNet/IP and Sercos devices to be managed on the same cable.

Modicon M262 Motion controller, optimized local I/O with Modicon TM3

Modicon TM5 Safety logic controller, Modicon TM5 Sercos interface module, Modicon TM5 Safety I/O, Modicon TM7 Safety I/O

Optimized I/O with Modicon TM3: Distributed I/O on Ethernet with TM3 bus coupler

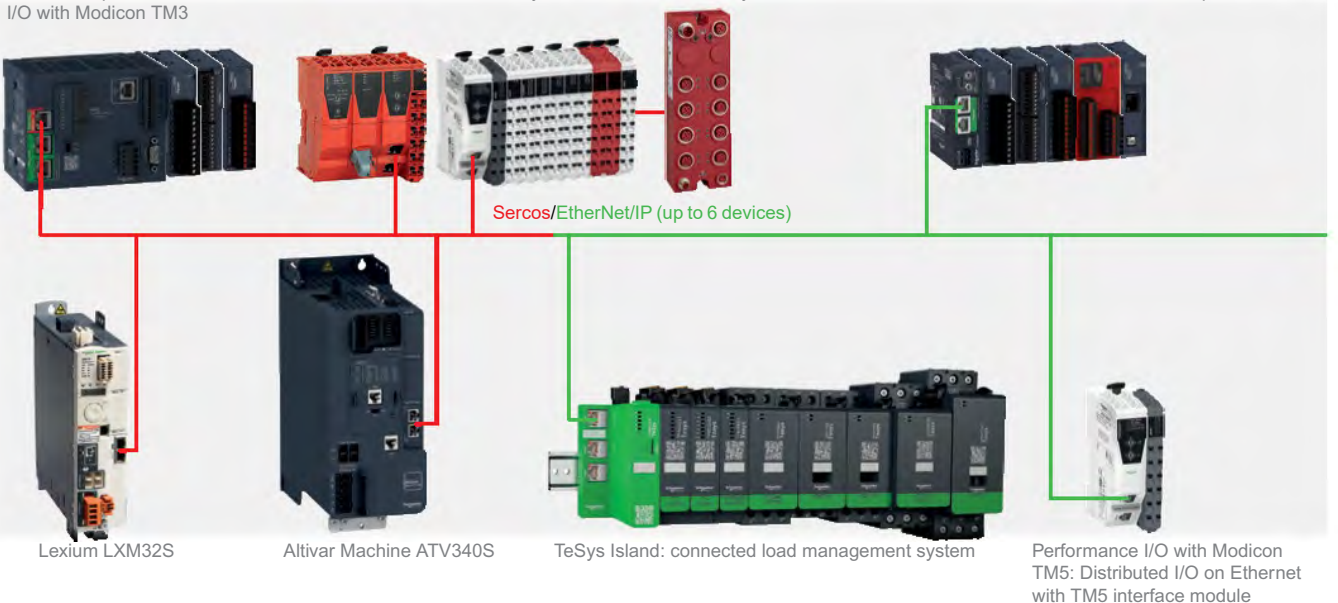

Lexium LXM32S

Altivar Machine ATV340S

TeSys Island: connected load management system

Performance I/O with Modicon TM5: Distributed I/O on Ethernet with TM5 interface module



General overview

Altivar Machine

Altivar ATV340

Applications

Altivar Machine ATV340 drives embed functions for high-performance machine requirements in the following applications:

- Packaging
- Consumer packaged goods machinery
- Material working
- Material handling
- Hoisting
- Textiles
- Pumping
- General machine control



Packing and packaging machines



Consumer packaged goods machinery



Material working



Material handling



Hoisting



Textile application



Pumping



General machine control

A

B

C

D

E

F

G

H

I

J

- A
- B
- C
- D
- E**
- F
- G
- H
- I
- J

General overview

Altivar Building

Altivar 212

A



B

C

D

E



Ventilation application

F



Air conditioning application

G

H

I

J



Pumping application

Presentation

The Altivar 212 drive is a frequency inverter for 0.75 kW to 75 kW three-phase asynchronous motors.

It has been designed for the most common fluid management applications (HVAC "Heating, Ventilation and Air Conditioning") in buildings the service sector:

- Ventilation
- Heating and air conditioning
- Pumping

Its design is based on eco-energy with a reduction in energy consumption of up to 70% compared to a conventional control system.

It is eco-friendly and complies with directives such as RoHS, WEEE, etc. relating to environmental protection.

The Altivar 212 is operational from the moment the power is turned on; it can be used to achieve your building's maximum energy efficiency (see the "Energy gain" curve on the previous pages).

Optimisation of building management

The Altivar 212 drive has been designed to considerably improve building management by:

- Simplifying circuits by removing flow control valves and dampers,
- Offering flexibility and ease of adjustment for installations, thanks to its compatibility with building management system connectivity
- Reducing noise pollution (noise caused by air flow and motor)

Its various standard versions make it possible to reduce installation costs by integrating EMC filters, categories C1 to C3 depending on the model, which has the following advantages:

- More compact size
- Simplified wiring, thus reduced cost

The Altivar 212 offer helps to reduce equipment costs while optimizing its performance.

Compliance with international standards and certifications

The Altivar 212 offer has been designed to conform to the strictest international standards and in accordance with recommendations relating to electrical industrial control devices, including the Low Voltage Directive and IEC/EN 61800-5-1.

It takes into account observing requirements in respect of electromagnetic compatibility and conforms to international standard IEC/EN 61800-3 (immunity and conducted and radiated EMC emissions).

The entire range has obtained e marking according to the European Low Voltage (2006/95/EC) and EMC (2004/108/EC) Directives.

The range is UL, CSA, C-Tick and NOM certified.

Flexible communication adapted to building management

The Altivar 212 drive can easily be adapted to all building management systems thanks to its numerous functions and communication protocols integrated as standard: Modbus, METASYS N2®, APOGEE FLN P1® and BACnet®.

With protocols offered as standard and the LonWorks® communication card offered as an option, the Altivar 212 drive is optimized for the building market (HVAC).

Quick and easy dialogue to make your installations easier to use

Numerous dialogue and configuration tools are also included in the Altivar 212 offer, making running installations quick, easy and cost-effective.

Orientated towards performance, intelligence and building protection

Dedicated HVAC^[1] variable speed drive for pumps, fans and compressors.
For 0.75 to 75kW - 1 to 100 hp motors.

Focused on Building Management Systems (BMS)

- Easy integration to building supervision network using embedded protocols.
- Instant detection of system failure: belt breakage, pump running dry, phase failure, etc.
- Preventive maintenance for reducing costs: fault alert, operating time, etc.
- Energy consumption monitoring.

Focused on user-friendliness

- Easy set-up, commissioning and diagnostics tools: remote graphic terminal (6 languages as standard), Multi-Loader, PC Software, Bluetooth capability and SoMove Mobile software.
- Compact size for better integration.

Focused on cost savings

- Reduced investment costs (embedded functionalities).
- Quick return on investment (energy saving).

Focused on protection & efficiency

- Continuity of service.
- Functions designed for buildings: fire mode, damper monitoring, mechanical protection, etc.
- Integrated EMC filter.
- Antiharmonic technology (THDI \approx 30%).

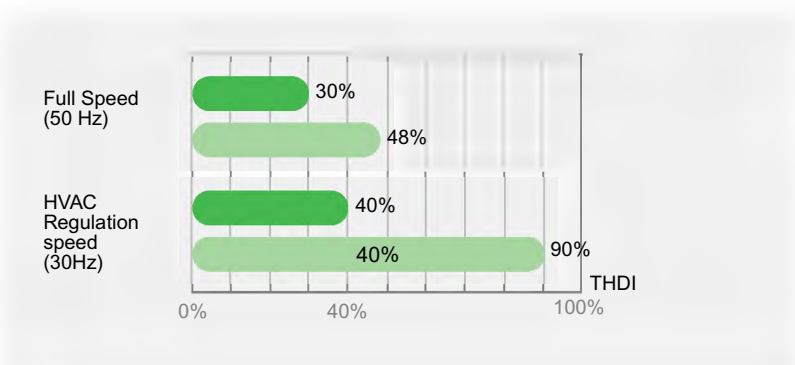

■ Altivar 212 antiharmonic technology
■ Drives with integrated DC choke

[1] HVAC: Heating, Ventilation, Air Conditioning.



General overview

Altivar Building

Altivar 212

A single product

Ventilation

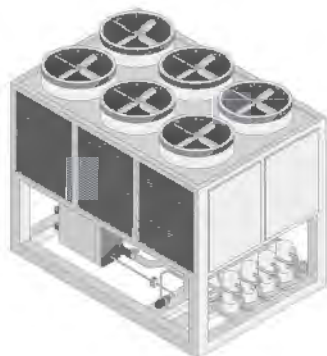

Air cooling unit

Heating and air conditioning

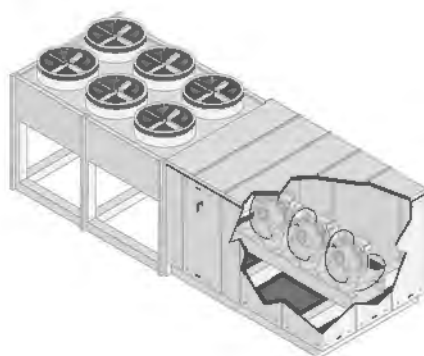

Condensation unit

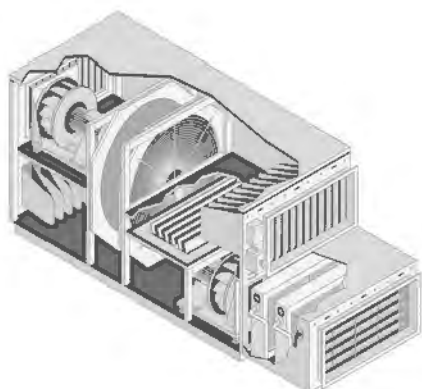

Air Handling Unit

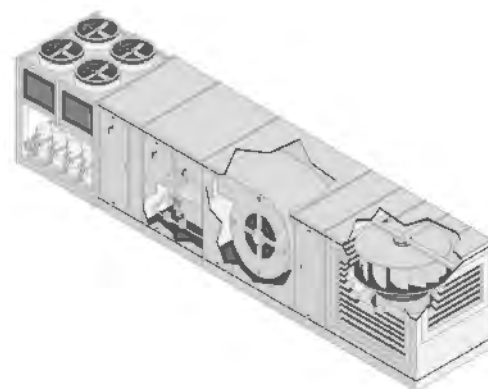

Roof Top Unit: ventilation block

Comfort

- Reduce noise pollution (air flow, motor, etc.).

Security

- Detection of belt breakage.
- Smoke extraction: forced operation with fault inhibition.

Simplicity

- Automatic restart.
- Damper management.
- Preset speeds for a simple automatic control sequence.

Performance

- Optimise control when processing fluids.
- Use of PID regulator (temperature, flow rate, pressure, etc.).

Cost savings

- Flow rates adjustment for better energy management.
- Energy saving mode.

Robustness

- Suppression of mechanical resonance.

Building management system

- Connection to building supervision network.

Save up to 70% on your energy bill!

Whatever the fluid (air, water), the Altivar 212 makes your buildings more comfortable, easier to manage and, at the same time, saves energy.

ECO_{2.0} for HVAC

Estimate energy savings on your pump and fan applications

ECO_{2.0} a free, multi-platform software to estimate energy savings and the payback period for an Altivar variable speed drive^[1] installation.

- Easy and fast access to energy and CO₂ information.
- Customization with your own application motor data.
- Direct access to your drives-related technical information.
- Send and receive your project report by email.
- Decision-making support to identify the optimal Energy Efficient solution.
- Available for PC, tablet or smartphone online and offline as free download.

[1] Altivar 212, Altivar 61 and Altivar 61 Plus – from 0.37 to 2400 kW.



Power consumption (%)

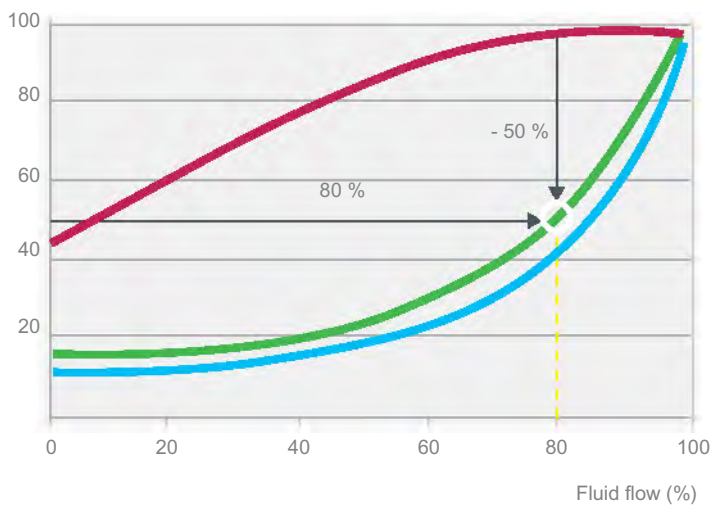

Illustrative curves only (not contractual)

- Traditional control system
- Altivar 212 standard torque ratio
- Altivar 212 energy savings quadratic torque ratio

At 80% flow rate, the energy consumption drops 50%. Using the Altivar 212, energy consumption is reduced on average by 30% when using the control mode dedicated to pumps and fans.

30%

average reduction in energy consumption by using the control mode dedicated to pumps and fans.



Altivar Building

Altivar 212

IP20 or IP21 variable speed drives for asynchronous and synchronous motors

A

B

C

D

E

F

G

H

I

J

Type of machine	Pumps and fans (building (HVAC)) ^[1]
	
	Altivar 212

Characteristics	
Power range for 50...60 Hz (kW/HP) line supply	0.75...75/1...100
Single-phase 100...120 V (kW/HP)	–
Single-phase 200...240 V (kW/HP)	–
Three-phase 200...230 V (kW/HP)	–
Three-phase 200...240 V (kW/HP)	0.75...30/1...40
Three-phase 380...480 V (kW/HP)	0.75...75/1...100
Three-phase 380...500 V (kW/HP)	–
Three-phase 500...600 V (kW/HP)	–
Three-phase 525...600 V (kW/HP)	–
Three-phase 500...690 V (kW/HP)	–
Degree of protection	IP21
Type of cooling ^[2]	Heatsink
Drive	Output frequency 0.5...200 Hz
Type of control	Asynchronous motor
	<ul style="list-style-type: none"> ■ Sensorless flux vector control ■ Voltage/frequency ratio (2 points) ■ Energy saving ratio
	Synchronous motor
	–
Transient overtorque	120% of the nominal motor torque

Functions	
Number of functions	50
Number of preset speeds	7
Number of I/O	Analog inputs 2
	Logic inputs 3
	Analog outputs 1
	Logic outputs –
	Relay outputs 2
Communication	Integrated Modbus, METASYS N2, APOGEE FLN, BACnet
	Available as an option LonWorks
Cards (available as an option)	–
Dialogue tools	IP54 or IP65 remote graphic display terminal
Configuration tools	Setup software PCSoft for ATV 212
	Configuration tools Multi-Loader
Standards and certifications	<ul style="list-style-type: none"> ■ IEC 61800-5-1 ■ IEC 61800-3 (environments 1 and 2, categories C1 to C3, cat. C1 with option for ATV 212) ■ EN 55011: Group 1, class A and class B with option card. ■ CE, UL, CSA, C-Tick, NOM

References	ATV 212
------------	---------

[1] Heating, Ventilation and Air Conditioning.
 [2] The type of cooling depends on the model.

- A
- B
- C
- D
- E**
- F
- G
- H
- I
- J

General overview

Altivar Process

Altivar ATV600



Altivar Process range

Process

Altivar Process drives are specifically designed to meet the requirements of following market segments:

- Water & wastewater
- Oil & gas
- Mining, minerals & metals
- Consumer packaged goods (CPG)

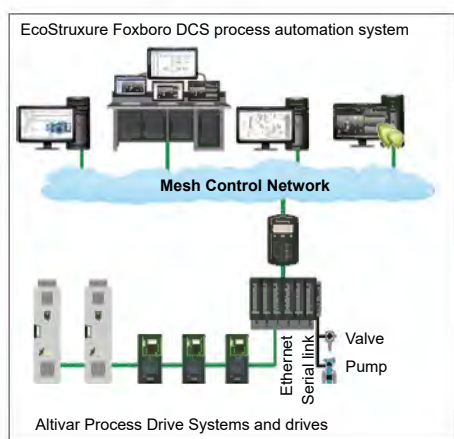

Altivar Process in EcoStruxure Foxboro DCS architecture

EcoStruxure Plant™ integration

The association of Altivar Process services with Schneider Electric process automation control systems like EcoStruxure Foxboro DCS (for process systems) or EcoStruxure Hybrid DCS (for hybrid systems) offers a high-performance, global automation and motor control solution with optimized total cost of ownership (TCO).

The solution provides operational integrity for people, processes, and assets, with improved maintenance support to reduce downtime and helps to ensure operation continuity.

It offers operational insight by accessing more information to optimize the process and control energy efficiency.

Based on market standards (FDT/DTM, Ethernet, etc.), it is a sustainable, scalable solution that enables processes to be adapted easily and affordably.

Applications

Altivar Machine ATV600 drives embed functions for high-performance machine requirements in the following applications:



Water & wastewater



Oil & gas



Mining, minerals & metals



Consumer packaged goods (CPG)

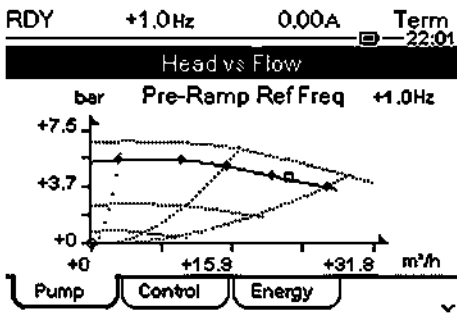

Pump monitoring display

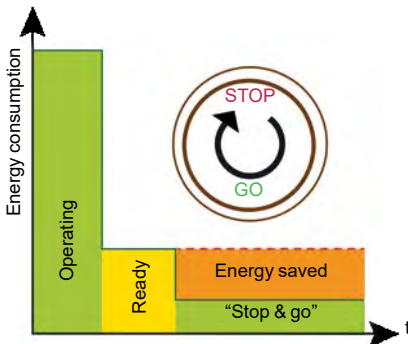

"Stop & go" function



Configure your Altivar drive with the EcoStruxure™ Motor Control Configurator

Business optimization

Optimum monitoring of your process

- Instant reaction if pump efficiency drops thanks to embedded pump monitoring
- Notification of critical operating points without additional sensors
- Process integration with pressure, flow, and level control including compensation of flow losses.

Energy-saving drive solution

- Up to 30% energy saving when on standby due to the innovative "stop & go" operation without additional costs
- Smart control of the internal fans depending on operation
- Optimum energy efficiency over the whole lifecycle
- Data logging and graphic display of the power consumption.

Real-time intelligence

Web server and services via Ethernet

- Embedded Web server interface based on the Ethernet network gives you process monitoring with your daily working tools.
- Local and remote access to energy use and customized dashboards means your energy is visible anywhere, any time, on PC, tablet, or smartphone.

User-friendliness

Simple integration in PLC environments

- Easy integration thanks to standardized FDT/DTM and ODVA technology
- Supported by predefined EcoStruxure Control Expert libraries
- Easy access via PC, tablet, or smartphone
- Robust connection via Ethernet.

Sophisticated service concept

- Modular design provides easy spare parts logistics
- Optimized maintenance costs due to dynamic maintenance schedule, with integrated monitoring of individual components
- Simple exchange of power modules and fans
- Quick assistance with dynamic QR codes and Customer Care app.



Scanning the QR code from a smartphone or tablet

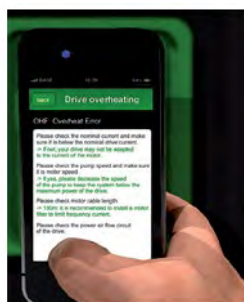

Instant access to online help



Altivar Process

Altivar ATV600

A

B

C

D

E

F

G

H

I

J

Market segments	
	Water & wastewater, oil & gas, mining, minerals & metals, consumer packaged goods (CPG)



Characteristics

Mounting type		Wall mounting
Degree of protection		IP20 and IP21/UL Type 1
Power range for 50...60 Hz line supply	Three-phase: 200...240 V (kW/HP)	0.75...75/1...100
	Three-phase: 380...440 V (kW)	–
	Three-phase: 380...480 V (kW/HP)	0.75...315/1...500
	Three-phase: 500...690 V (kW/HP)	1.5...75/2...100
Drive	Output frequency	0.1...500 Hz
	Control type	Asynchronous motor: Standard constant torque, variable standard torque, optimized torque mode Synchronous motor: PM (permanent magnet) motor, synchronous reluctance motor

Functions

Advanced functions		<ul style="list-style-type: none"> ■ Accurate measurement for monitoring system energy consumption (deviation < 5%) ■ Installation energy drift detection ■ Embedded Ethernet with direct access to system configuration and monitoring ■ Integration of actual pump curves to optimize the system operating point ■ Optimized pump monitoring based on actual operating point ■ Sensorless estimated flow rate ■ Measurements expressed in working units (e.g. m³/h, kWh/m³) ■ Limitation of overvoltage at the motor terminals ■ Contextual access to technical documentation through dynamic QR code ■ Continuous and historical real-time measurements with customizable dashboards ■ Predictive and preventive maintenance tracking functions (e.g. temperature with PT100/1000 probe, fan monitoring)
Number of integrated I/O	Integrated safety function	1: STO (Safe Torque Off) SIL3
	Number of preset speeds	16
	Analog inputs	3: Configurable as voltage (0...10 V) or current (0-20 mA/4-20 mA), 2 of them including probes (PTC, PT100, PT1000, or KTY84)
	Digital inputs	6: Voltage 24 V c (positive or negative logic)
	Analog outputs	2: Configurable as voltage (0...10 V) or current (0-20 mA)
Extended I/O module (optional)	Relay outputs	3: 1 with NO/NC contacts and 2 with NO contacts
	Safety function inputs	2: For safety function STO
	Analog inputs	2 differential analog inputs configurable via software as current (0-20 mA/4-20 mA), or for PTC, PT100, or PT1000, 2- or 3-wire probe
Extended relay module (optional)	Digital inputs	6: Voltage 24 V c (positive or negative logic)
	Digital outputs	2: Assignable
Extended relay module (optional)	Relay outputs	3: NO contacts
	Communication	Integrated
Option modules		EtherNet/IP and Modbus/TCP dual port, ProfiNet, CANopen RJ45 daisy chain, SUB-D, and screw terminal block, Profibus DP V1, DeviceNet, and BACnet MS/TP
Configuration and runtime tools		Graphic display terminal, embedded Web server, DTM (Device Type Manager), SoMove software
Standards and certifications		UL 508C and UL61800-5-1 ^[1] , EN/IEC 61800-3, EN/IEC 61800-3 environment 1 category C2, EN/IEC 61800-3 environment 2 category C3, EN/IEC 61800-5-1, IEC 61000-3-12, IEC 60721-3, IEC 61508 ^[2] , ATEX 2/22, ATEX 1/21, SEMI F47-0706

References

ATV630●●●●●

[1] Evaluated UL standards may differ per drive reference. Please refer to our website for more details.
 [2] For marine product certificate, please contact your Schneider Electric representative.

Market segments		
Water & wastewater, oil & gas, mining, minerals & metals, consumer packaged goods (CPG)		
		
Characteristics		
Mounting type	Cabinet integration	
Drive type	Drive products for cabinet integration	
Degree of protection	IP20	
Power range for 50...60 Hz line supply	Three phase: 380...480 V (kW/HP) 0.75...90/1...120	
	Three-phase: 400 V (kW) –	
	Three-phase: 440 V (kW) –	
	Three-phase: 480 V (HP) –	
	Three-phase: 500 (kW) –	
	Three-phase: 600 (HP) –	
	Three-phase: 690 (kW) –	
Drive	Output frequency 0.1...500 Hz	
	Control type Asynchronous motor Standard constant torque, variable standard torque, optimized torque mode	
	Synchronous motor PM (permanent magnet) motor, synchronous reluctance motor	
Functions		
Advanced functions	<p>Including all the advanced features of ATV600 drives:</p> <ul style="list-style-type: none"> ■ Accurate measurement for monitoring system energy consumption (deviation < 5%) ■ Installation energy drift detection ■ Embedded Ethernet with direct access to system configuration and monitoring ■ Integration of actual pump curves to optimize the system operating point ■ Optimized pump monitoring based on actual operating point ■ Sensorless estimated flow rate ■ Measurements expressed in working units (e.g. m³/h, kWh/m³) ■ Limitation of overvoltage at the motor terminals ■ Contextual access to technical documentation through dynamic QR code ■ Continuous and historical real-time measurements with customizable dashboards ■ Predictive and preventive maintenance tracking functions (e.g. temperature with PT100/1000 probe, fan monitoring) ■ Easy setting of drive identification for Altivar Process Modular drives 	
Number of integrated I/O	Integrated safety function	1: STO (Safe Torque Off) SIL3
	Number of preset speeds	16
	Analog inputs	3: Configurable as voltage (0...10 V) or current (0-20 mA/4-20 mA), 2 of them including probes (PTC, PT100, PT1000, or KTY84)
	Digital inputs	6: Voltage 24 V c (positive or negative logic)
	Digital output	–
Extended I/O module (optional)	Analog outputs	2: Configurable as voltage (0...10 V) or current (0-20 mA)
	Relay outputs	3: 1 with NO/NC contacts and 2 with NO contacts
	Safety function inputs	2: For safety function STO
	Analog inputs	2 differential analog inputs configurable via software as voltage (0...±10 V) or current (0-20 mA/4-20 mA), or for PTC, PT100, or PT1000 2- or 3-wire probes
	Digital inputs	6: Voltage 24 V c (positive or negative logic)
Extended relay module (optional)	Digital outputs	2: Assignable
	Relay outputs	3: NO contacts
Communication	Integrated	Modbus/TCP, Modbus serial link
	Option modules	Ethernet/IP, Modbus TCP and MD-Link dual port, CANopen RJ45 daisy chain, SUB-D, and screw terminal block, PROFINET, PROFIBUS DP V1, DeviceNet, BACnet MS/TP, POWERLINK
Configuration and runtime tools		Graphic display terminal, embedded Web server, DTM (Device Type Manager), SoMove software
Standards and certifications		86/188/EEC, IEC 61000-4-2, IEC 61000-4-3, IEC 61000-4-4, IEC 61000-4-5, IEC 61000-4-6, EN/IEC 61800-3, EN/IEC 61800-5-1, IEC 61000-3-12, IEC 60721-3, IEC 61508, IEC 13849-1, TÜV certification, e marking, ATEX 2/22, ATEX 1/21
References		
ATV630●●●N4Z		

General overview

Altivar Process

Altivar ATV900



Altivar Process range

Process automation

Altivar Process drives are specifically designed to meet the requirements of the following market segments:

- Oil & gas
- Mining, minerals & metals
- Consumer packaged goods (CPG)
- Water & wastewater

The Altivar Process 900 series is focused on maximum productivity with exceptional motor control and connectivity.

It offers special functions for industrial process segments:

- Excellent motor performance on any type of motor
- Total control of any kind of coupling in master/slave applications
- Network services to help ensure operation continuity even in case of connection breakdown
- Web server and data logging to help reduce downtime through rapid troubleshooting and preventive maintenance

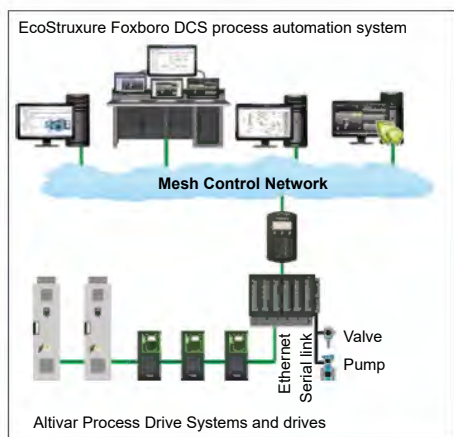

Altivar Process Drive Systems and drives in EcoStruxure Foxboro DCS architecture

EcoStruxure Plant™ integration

The association of Altivar Process services with Schneider Electric process automation control systems like EcoStruxure Foxboro DCS (for process systems) or EcoStruxure Hybrid DCS (for hybrid systems) offers a high-performance, global automation and motor control solution with optimized total cost of ownership (TCO).

The solution provides operational integrity for people, processes, and assets, with improved maintenance support to help reduce downtime and ensure operation continuity.

It offers operational insight by accessing more information to optimize the process and control energy efficiency.

Based on market standards (FDT/DTM, Ethernet, etc.), it is a sustainable, scalable solution that enables processes to be adapted easily and affordably.

Applications

Altivar Machine ATV600 drives embed functions for high-performance machine requirements in the following applications:



Water & wastewater



Oil & gas



Mining, minerals & metals



Consumer packaged goods (CPG)

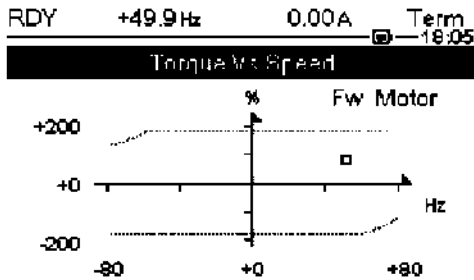

Torque Vs Speed display

Process efficiency

Motor performance and connectivity

- Excellent motor performance on any type of motor
- Ethernet dual port offers maximum services such as connection to the control room and process transparency
- Network service helps ensure operation continuity even in case of connection breakdown
- Web server and data logging help reduce downtime through fast troubleshooting and preventive maintenance.

Complete control of your applications

- Maximize your application performance by using drive-to-drive communication: total control of any kind of coupling in master/slave applications
- Total management and flexibility of speed and torque on rigid and elastic coupling
- Asset monitoring functions to increase production and reduce downtime.

Real-time intelligence

Web server and services via Ethernet

- Embedded Web server interface based on the Ethernet network gives you process monitoring with your daily working tools.
- Local and remote access to energy use and customized dashboards means your energy is visible anywhere, any time, on PC, tablet, or smartphone.

User-friendliness

Simple integration in PLC environments

- Easy integration thanks to standardized FDT/DTM and ODVA technology
- Supported by predefined EcoStruxure Control Expert libraries
- Easy access via PC, tablet, or smartphone
- Robust connection via Ethernet.

Sophisticated service concept

- Modular design provides easy spare parts logistics
- Optimized maintenance costs due to dynamic maintenance schedule, with integrated monitoring of individual components
- Simple exchange of power modules and fans
- Quick assistance with dynamic QR codes and Customer Care App.



Configure your Altivar drive with the EcoStruxure™ Motor Control Configurator



Scanning the QR code from a smartphone or tablet

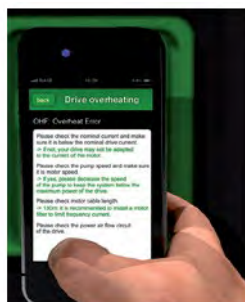

Instant access to online help



Altivar Process

Altivar ATV900

A

B

C

D

E

F

G

H

I

J

Market segments	
	Oil & gas, mining, minerals & metals, consumer packaged goods (CPG), water & wastewater
	

Characteristics													
Mounting type	Wall-mounting												
Degree of protection	IP20 and IP21/UL Type 1 IP21/UL Type 1 without braking unit												
Power range for 50...60 Hz line supply^[1]	<table border="1"> <tr> <td>Three-phase: 200...240 V (kW/HP)</td> <td>0.75...45/1...60</td> <td>30...75/40...100</td> </tr> <tr> <td>Three-phase: 380...440 V (kW)</td> <td>–</td> <td>–</td> </tr> <tr> <td>Three-phase: 380...480 V (kW/HP)</td> <td>0.75...220/1...350</td> <td>55...315/75...500</td> </tr> <tr> <td>Three-phase: 500...690 V (kW/HP)</td> <td>1.5...75/2...100</td> <td>–</td> </tr> </table>	Three-phase: 200...240 V (kW/HP)	0.75...45/1...60	30...75/40...100	Three-phase: 380...440 V (kW)	–	–	Three-phase: 380...480 V (kW/HP)	0.75...220/1...350	55...315/75...500	Three-phase: 500...690 V (kW/HP)	1.5...75/2...100	–
Three-phase: 200...240 V (kW/HP)	0.75...45/1...60	30...75/40...100											
Three-phase: 380...440 V (kW)	–	–											
Three-phase: 380...480 V (kW/HP)	0.75...220/1...350	55...315/75...500											
Three-phase: 500...690 V (kW/HP)	1.5...75/2...100	–											
Drive	<table border="1"> <tr> <td>Output frequency</td> <td>0.1...599 Hz</td> </tr> <tr> <td>Control type</td> <td>Asynchronous motor: Standard constant torque, optimized torque mode Synchronous motor: PM (permanent magnet) motor, synchronous reluctance motor</td> </tr> </table>	Output frequency	0.1...599 Hz	Control type	Asynchronous motor: Standard constant torque, optimized torque mode Synchronous motor: PM (permanent magnet) motor, synchronous reluctance motor								
Output frequency	0.1...599 Hz												
Control type	Asynchronous motor: Standard constant torque, optimized torque mode Synchronous motor: PM (permanent magnet) motor, synchronous reluctance motor												

Functions																	
Functions	<p>Advanced functions</p> <ul style="list-style-type: none"> ■ High-performance motor control with an overload torque up to 180% Tn in an open or closed loop ■ Asynchronous, synchronous, special motors: all efficiency classes, brand independent, permanent magnet motors, torque motors, conical sliding rotor, reluctance motor ■ Integrated EtherNet/IP and Modbus TCP dual port, cybersecurity (Achilles Level 2) ■ Smart integration in PlantStruxure and Foxboro Evo process automation systems ■ Optimized energy efficiency, detection of energy consumption drift of the installation ■ Adaptation to the process by dedicated functions with modular design ■ Embedded safety functions STO SIL3 ■ Master/slave and load sharing with drive-to-drive capability: <ul style="list-style-type: none"> □ Torque sharing on rigid coupling □ Torque sharing on elastic coupling ■ Contextual access to technical documentation through dynamic QR code ■ Continuous and historical real-time measurements with customizable dashboards ■ Predictive maintenance (e.g. temperature with PT100/1000 probe, fan monitoring, etc.) <p>1: STO (Safe Torque Off) SIL3</p>																
Number of integrated I/O	<table border="1"> <tr> <td>Integrated safety function</td> <td>1: STO (Safe Torque Off) SIL3</td> </tr> <tr> <td>Number of preset speeds</td> <td>16</td> </tr> <tr> <td>Analog inputs</td> <td>3: 2 configurable as voltage (0...10 V) or current (0-20 mA/4-20 mA), including probes (PTC, PT100, PT1000, or KTY84), and 1 configurable as (0...±10 V)</td> </tr> <tr> <td>Digital inputs</td> <td>8: Voltage 24 V c (positive or negative logic)</td> </tr> <tr> <td>Digital output</td> <td>1: Assignable can be used as pulse train output (PTO)</td> </tr> <tr> <td>Analog outputs</td> <td>2: Configurable as voltage (0...10 V) or current (0-20 mA)</td> </tr> <tr> <td>Relay outputs</td> <td>3: 1 with NO/NC contacts and 2 with NO contacts</td> </tr> <tr> <td>Safety function inputs</td> <td>2: For safety function STO</td> </tr> </table>	Integrated safety function	1: STO (Safe Torque Off) SIL3	Number of preset speeds	16	Analog inputs	3: 2 configurable as voltage (0...10 V) or current (0-20 mA/4-20 mA), including probes (PTC, PT100, PT1000, or KTY84), and 1 configurable as (0...±10 V)	Digital inputs	8: Voltage 24 V c (positive or negative logic)	Digital output	1: Assignable can be used as pulse train output (PTO)	Analog outputs	2: Configurable as voltage (0...10 V) or current (0-20 mA)	Relay outputs	3: 1 with NO/NC contacts and 2 with NO contacts	Safety function inputs	2: For safety function STO
Integrated safety function	1: STO (Safe Torque Off) SIL3																
Number of preset speeds	16																
Analog inputs	3: 2 configurable as voltage (0...10 V) or current (0-20 mA/4-20 mA), including probes (PTC, PT100, PT1000, or KTY84), and 1 configurable as (0...±10 V)																
Digital inputs	8: Voltage 24 V c (positive or negative logic)																
Digital output	1: Assignable can be used as pulse train output (PTO)																
Analog outputs	2: Configurable as voltage (0...10 V) or current (0-20 mA)																
Relay outputs	3: 1 with NO/NC contacts and 2 with NO contacts																
Safety function inputs	2: For safety function STO																
Extended I/O module (optional)	<table border="1"> <tr> <td>Analog inputs</td> <td>2 differential analog inputs configurable via software as current (0-20 mA/ 4-20 mA), or for PTC, PT100 or PT1000, 2 or 3-wire probes</td> </tr> <tr> <td>Digital inputs</td> <td>6: Voltage 24 V c (positive or negative logic)</td> </tr> <tr> <td>Digital outputs</td> <td>2: Assignable</td> </tr> <tr> <td>Relay outputs</td> <td>3: NO contacts</td> </tr> </table>	Analog inputs	2 differential analog inputs configurable via software as current (0-20 mA/ 4-20 mA), or for PTC, PT100 or PT1000, 2 or 3-wire probes	Digital inputs	6: Voltage 24 V c (positive or negative logic)	Digital outputs	2: Assignable	Relay outputs	3: NO contacts								
Analog inputs	2 differential analog inputs configurable via software as current (0-20 mA/ 4-20 mA), or for PTC, PT100 or PT1000, 2 or 3-wire probes																
Digital inputs	6: Voltage 24 V c (positive or negative logic)																
Digital outputs	2: Assignable																
Relay outputs	3: NO contacts																
Extended relay module (optional)	<table border="1"> <tr> <td>Relay outputs</td> <td>3: NO contacts</td> </tr> </table>	Relay outputs	3: NO contacts														
Relay outputs	3: NO contacts																
Communication	<table border="1"> <tr> <td>Integrated</td> <td>EtherNet/IP and Modbus/TCP dual port, Modbus serial link</td> </tr> <tr> <td>Option modules</td> <td>CANopen RJ45 daisy chain, SUB-D, and screw terminal block, PROFINET, PROFIBUS DP V1, DeviceNet, EtherCAT, and POWERLINK</td> </tr> </table>	Integrated	EtherNet/IP and Modbus/TCP dual port, Modbus serial link	Option modules	CANopen RJ45 daisy chain, SUB-D, and screw terminal block, PROFINET, PROFIBUS DP V1, DeviceNet, EtherCAT, and POWERLINK												
Integrated	EtherNet/IP and Modbus/TCP dual port, Modbus serial link																
Option modules	CANopen RJ45 daisy chain, SUB-D, and screw terminal block, PROFINET, PROFIBUS DP V1, DeviceNet, EtherCAT, and POWERLINK																
Configuration and runtime tools	Graphic display terminal, embedded Web server, DTM (Device Type Manager), SoMove software																
Standards and certifications	UL 508C and UL61800-5-1 ^[2] , EN/IEC 61800-3, EN/IEC 61800-3 environment 1 category C2, EN/IEC 61800-3 environment 2 category C3, EN/IEC 61800-5-1, IEC 61000-3-12, IEC 60721-3, IEC 61508 (3), IEC 13849-1, REACH, SEMI F47-0706, ATEX 2/22, ATEX 1/21																
References	<table border="1"> <tr> <td>ATV930</td> <td>●●●●●●</td> </tr> <tr> <td>ATV930</td> <td>●●●●●●C</td> </tr> </table>	ATV930	●●●●●●	ATV930	●●●●●●C												
ATV930	●●●●●●																
ATV930	●●●●●●C																

^[1] in "Normal duty", power values are given for applications requiring a slight overload (up to 120%). For power values in "Heavy duty" applications requiring a significant overload (up to 150%), see page 60852/2.

^[2] Evaluated UL standards may differ per drive reference. Please refer to our website for more details.

^[3] For marine product certificate please contact your Schneider Electric representative.

Market segments																	
	Oil & gas, mining, minerals & metals, consumer packaged goods (CPG), water & wastewater																
																	
Characteristics																	
Mounting type	Cabinet integration																
Drive type	Drive products for cabinet integration																
Degree of protection	IP20																
Power range for 50...60 Hz line supply	<table border="1"> <tr> <td>Three phase: 380...480 V (kW/HP)</td> <td>0.75...90/1...120</td> </tr> <tr> <td>Three-phase: 400 V (kW)</td> <td>–</td> </tr> <tr> <td>Three-phase: 440 V (kW)</td> <td>–</td> </tr> <tr> <td>Three-phase: 480 V (HP)</td> <td>–</td> </tr> <tr> <td>Three-phase: 500 (kW)</td> <td>–</td> </tr> <tr> <td>Three-phase: 600 (HP)</td> <td>–</td> </tr> <tr> <td>Three-phase: 690 (kW)</td> <td>–</td> </tr> </table>	Three phase: 380...480 V (kW/HP)	0.75...90/1...120	Three-phase: 400 V (kW)	–	Three-phase: 440 V (kW)	–	Three-phase: 480 V (HP)	–	Three-phase: 500 (kW)	–	Three-phase: 600 (HP)	–	Three-phase: 690 (kW)	–		
Three phase: 380...480 V (kW/HP)	0.75...90/1...120																
Three-phase: 400 V (kW)	–																
Three-phase: 440 V (kW)	–																
Three-phase: 480 V (HP)	–																
Three-phase: 500 (kW)	–																
Three-phase: 600 (HP)	–																
Three-phase: 690 (kW)	–																
Drive	<table border="1"> <tr> <td>Output frequency</td> <td>0.1...599 Hz</td> </tr> <tr> <td>Control type Asynchronous motor</td> <td>Standard constant torque, variable standard torque, optimized torque mode</td> </tr> <tr> <td>Synchronous motor</td> <td>PM (permanent magnet) motor, synchronous reluctance motor</td> </tr> </table>	Output frequency	0.1...599 Hz	Control type Asynchronous motor	Standard constant torque, variable standard torque, optimized torque mode	Synchronous motor	PM (permanent magnet) motor, synchronous reluctance motor										
Output frequency	0.1...599 Hz																
Control type Asynchronous motor	Standard constant torque, variable standard torque, optimized torque mode																
Synchronous motor	PM (permanent magnet) motor, synchronous reluctance motor																
Functions																	
Functions	<p>Advanced functions</p> <p>Including all the advanced features of ATV900 drives:</p> <ul style="list-style-type: none"> ■ High-performance motor control with an overload torque up to 180% Tn in an open or closed loop ■ Asynchronous, synchronous, special motors: all efficiency classes, brand independent, permanent magnet motors, torque motors, conical sliding rotor, reluctance motor ■ Integrated EtherNet/IP and Modbus TCP dual port, cybersecurity (Achilles Level 2) ■ Smart integration in PlantStruxure and Foxboro Evo process automation systems ■ Optimized energy efficiency, detection of energy consumption drift of the installation ■ Adaptation to the process by dedicated functions with modular design ■ Embedded safety functions STO SIL3 ■ Master/slave and load sharing with drive-to-drive capability: <ul style="list-style-type: none"> □ Torque sharing on rigid coupling □ Torque sharing on elastic coupling ■ Contextual access to technical documentation through dynamic QR code ■ Continuous and historical real-time measurements with customizable dashboards ■ Predictive maintenance (e.g. temperature with PT100/1000 probe, fan monitoring, etc.) ■ Easy setting of drive identification 																
Number of integrated I/O	<table border="1"> <tr> <td>Integrated safety function</td> <td>1: STO (Safe Torque Off) SIL3</td> </tr> <tr> <td>Number of preset speeds</td> <td>16</td> </tr> <tr> <td>Analog inputs</td> <td>3: 2 configurable as voltage (0...10 V) or current (0-20 mA/4-20 mA), including probes (PTC, PT100, PT1000, or KTY84), and 1 configurable as voltage (0...±10 V)</td> </tr> <tr> <td>Digital inputs</td> <td>8: Voltage 24 V \overline{c} (positive or negative logic)</td> </tr> <tr> <td>Digital output</td> <td>1: Assignable, can be used as PTO (pulse train output)</td> </tr> <tr> <td>Analog outputs</td> <td>2: Configurable as voltage (0...10 V) or current (0-20 mA)</td> </tr> <tr> <td>Relay outputs</td> <td>3: 1 with NO/NC contacts and 2 with NO contacts</td> </tr> <tr> <td>Safety function inputs</td> <td>2: For safety function STO</td> </tr> </table>	Integrated safety function	1: STO (Safe Torque Off) SIL3	Number of preset speeds	16	Analog inputs	3: 2 configurable as voltage (0...10 V) or current (0-20 mA/4-20 mA), including probes (PTC, PT100, PT1000, or KTY84), and 1 configurable as voltage (0...±10 V)	Digital inputs	8: Voltage 24 V \overline{c} (positive or negative logic)	Digital output	1: Assignable, can be used as PTO (pulse train output)	Analog outputs	2: Configurable as voltage (0...10 V) or current (0-20 mA)	Relay outputs	3: 1 with NO/NC contacts and 2 with NO contacts	Safety function inputs	2: For safety function STO
Integrated safety function	1: STO (Safe Torque Off) SIL3																
Number of preset speeds	16																
Analog inputs	3: 2 configurable as voltage (0...10 V) or current (0-20 mA/4-20 mA), including probes (PTC, PT100, PT1000, or KTY84), and 1 configurable as voltage (0...±10 V)																
Digital inputs	8: Voltage 24 V \overline{c} (positive or negative logic)																
Digital output	1: Assignable, can be used as PTO (pulse train output)																
Analog outputs	2: Configurable as voltage (0...10 V) or current (0-20 mA)																
Relay outputs	3: 1 with NO/NC contacts and 2 with NO contacts																
Safety function inputs	2: For safety function STO																
Extended I/O module (optional)	<table border="1"> <tr> <td>Analog inputs</td> <td>2 differential analog inputs configurable via software current (0-20 mA/4-20 mA), or for PTC, PT100, or PT1000 2- or 3-wire probes</td> </tr> <tr> <td>Digital inputs</td> <td>6: Voltage 24 V \overline{c} (positive or negative logic)</td> </tr> <tr> <td>Digital outputs</td> <td>2: Assignable</td> </tr> <tr> <td>Relay outputs</td> <td>3: NO contacts</td> </tr> </table>	Analog inputs	2 differential analog inputs configurable via software current (0-20 mA/4-20 mA), or for PTC, PT100, or PT1000 2- or 3-wire probes	Digital inputs	6: Voltage 24 V \overline{c} (positive or negative logic)	Digital outputs	2: Assignable	Relay outputs	3: NO contacts								
Analog inputs	2 differential analog inputs configurable via software current (0-20 mA/4-20 mA), or for PTC, PT100, or PT1000 2- or 3-wire probes																
Digital inputs	6: Voltage 24 V \overline{c} (positive or negative logic)																
Digital outputs	2: Assignable																
Relay outputs	3: NO contacts																
Extended relay module (optional)	3: NO contacts																
Communication	<table border="1"> <tr> <td>Integrated</td> <td>EtherNet/IP, Modbus/TCP dual port, Modbus serial link</td> </tr> <tr> <td>Option modules</td> <td>CANopen RJ45 daisy chain, SUB-D, and screw terminal block, PROFINET, PROFIBUS DP-V1, DeviceNet, EtherCAT, and POWERLINK</td> </tr> </table>	Integrated	EtherNet/IP, Modbus/TCP dual port, Modbus serial link	Option modules	CANopen RJ45 daisy chain, SUB-D, and screw terminal block, PROFINET, PROFIBUS DP-V1, DeviceNet, EtherCAT, and POWERLINK												
Integrated	EtherNet/IP, Modbus/TCP dual port, Modbus serial link																
Option modules	CANopen RJ45 daisy chain, SUB-D, and screw terminal block, PROFINET, PROFIBUS DP-V1, DeviceNet, EtherCAT, and POWERLINK																
Configuration and runtime tools	Graphic display terminal, embedded Web server, DTM (Device Type Manager), SoMove software																
Standards and certifications	86/188/EEC, IEC 61000-4-2, IEC 61000-4-3, IEC 61000-4-4, IEC 61000-4-5, IEC 61000-4-6, EN/IEC 61800-3, EN/IEC 61800-5-1, IEC 61000-3-12, IEC 60721-3, IEC 61508, IEC 13849-1, TÜV certification, CE marking, ATEX 2/22, ATEX 1/21																
References	ATV930●●●N4Z																

Altivar Soft Starter ATS480

Soft starters for asynchronous motors



Altivar Soft Starter ATS480 range

Presentation

Enables a secure and digital area

Altivar Soft Starter ATS480 is the new range of soft starters from Schneider Electric designed to digitize the entire life cycle. Powered digitally by EcoStruxure, ATS480 increases efficiency from selection to maintenance.

Altivar Soft Starter ATS480 had been designed to:

- Respect cybersecurity requirements and usages according to the IEC 62443 standard
- Meet the requirements of the most stringent applications in normal and heavy duty
- Cover the operational voltage range from 208 to 690 V in a single product range up to 1200 A.

Extending the service life of ATS48 equipment

Easy replacement of ATS48 by ATS480

- Same footprint and fixings
- Same I/O
- Same parameters
- Same application behavior
- Keep the same devices, such as circuit breaker and contactors
- Transfer an ATS48 configuration to the ATS480 using SoMove Converter.

Make way for evolution

- Connection to the main fieldbuses on the market
 - Modbus TCP
 - EtherNet/IP
 - CANopen
 - PROFINET
 - PROFIBUS DP
 - Modbus serial
- Firmware update of the product and options
 - Single update: point-to-point
 - Mass update: multi-point
- Reinforced robustness
 - Conformal coating of printed circuit board
 - Compliance with IEC/EN 60721-3-3 Class 3C3
 - Combination with TeSys Deca and Giga

Reducing engineering time and cost

With EcoStruxure tools, integrated automation system, and ATS480 Device Type Manager, the engineering time is drastically reduced all along the process from selection to project execution.

- It takes just two minutes to select the complete soft starter solution with EcoStruxure Motor Control Configurator: no need to be an expert
- Optimization of the power architecture with EcoStruxure Motor Management Design
 - Analysis of different solutions
 - Selection of the preferred devices according to the architecture
- Definition of the architecture and detailed design with EcoStruxure Plant Builder including the Bill of Material and quotation
- With ATS480 DTM, associated derived function block (DFB), and faceplate:
 - Quickly write the PLC program in EcoStruxure Control Expert
 - Integrate ready-to-use faceplate in AVEVA System Platform
 - Adapt and modify parameters without stopping the installation
 - Set, monitor, and diagnose from the engineering station
 - DFB and faceplate available in General Purpose libraries
- Mass firmware update with EcoStruxure Automation Device Maintenance

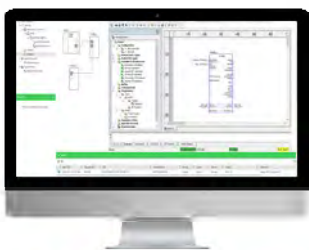

EcoStruxure
Innovation At Every Level

Altivar Soft Starter ATS480

Soft starters for asynchronous motors

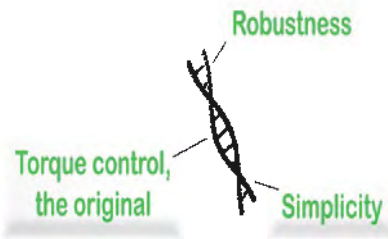

Achilles™ Level 2 certified

Helping to secure operations

The worthy successor of ATS48

Altivar Soft Starter ATS480 has inherited the best of ATS48 recognized and proven attributes:

- Torque control, the original: Pioneer of the torque control system (TCS), the Schneider Electric algorithm has been copied by major manufacturers but is still at the leading edge
- Robustness: In terms of starting capabilities, even in the most demanding applications
- Simplicity: Just set a few parameters displayed in plain text in your language and you are ready to start
- Asset monitoring:
 - Monitoring of the motor with internal electronic thermal relay, PTC, or PT100 probe
 - Monitoring of the mechanics and hydraulics with control of acceleration and deceleration
 - Monitoring of the main supply and others loads connected by reducing the voltage drop during starting

Increased continuity of service

- Bypass according to AC3 for full back-up solution
- No downtime in case of contactor failure: ATS480 thyristors are able to supply the motor during the start and stop phase, but also during steady state operations at the rated speed
- Fast replacement of standard contactor by maintenance technician: no need for complete disassembly of the soft starter to replace an internal contactor

Cybersecurity best practices

- User account management that includes user authentication, authorization according to the access channels, and strong passwords
- Hardening to restrict ports, functions, or services
- Threat intelligence to manage cybersecurity-related events
- Cybersecurity-compliant firmware upgrade

Embedded troubleshooting and digital support

- Easy root cause identification of warnings and detected errors
- Embedded test routine when connected inside motor delta
- Direct access to error page of documentation thanks to dynamic QR code
- QR code to documentation on the front of the ATS480

Superior sustainability

Altivar Soft Starter ATS480 is a Green Premium product designed to take account of environmental considerations. With the Schneider Electric Green Premium ecolabel, ATS480 meets the following requirements:

- Use of hazardous substances
 - Compliance with the European RoHS directive (2011/65/EU and 2015/863/ EU) and RoHS China
 - Compliance with REACH regulation No.1907/2006 for the declaration of substances of very high concern (SVHC), authorization (Annex XIV), and restriction (Annex XVII)
 - In terms of restrictions, Green Premium goes beyond current directives and regulations
- Environmental impact

The Product Environmental Profile (PEP) is a quantitative Type III Environmental Declaration in compliance with ISO 14025 that ensures appropriate reliability and transparency. Based on a Life Cycle Assessment (LCA) of the product along its whole life cycle, the document presents the different impacts such as energy consumption, carbon footprint, consumption of raw materials, and pollution of air, water, and soil.
- End-of-Life management

The "ATS480 End-of-life" information document in accordance with IEC 62635 guidance contains the instructions for a responsible disposal of the products and maximizes recycling in a step towards a more circular economy, improving operational efficiency and reducing environmental hazards.
- Upgradeability

Altivar Soft Starter ATS480 can be upgraded with additional power options or firmware.

General overview

Altivar Soft Starter ATS480

Soft starters for asynchronous motors

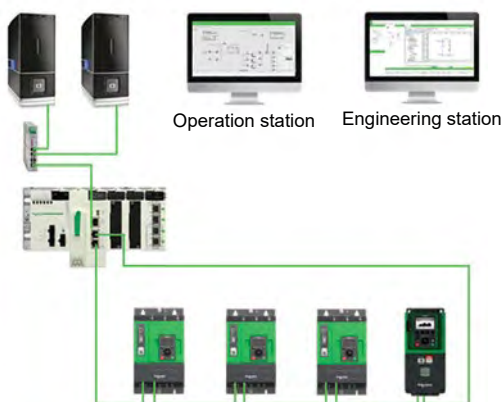

Process, infrastructures, and industrial machines

Altivar Soft Starter ATS480 is specifically designed to meet the requirements of the following market segments:

- Water and wastewater
- Oil and gas
- Mining, minerals, and metals
- Food and beverage
- Marine

ATS480 also meets the needs of industrial machines.

The Altivar Soft Starter ATS480 range increases availability, helps to ensure continuous operations, and reduces downtime thanks to its:

- Torque control
- Simplicity
- Connectivity
- Communication services
- Robustness

Applications

The Altivar Soft Starter ATS480 helps to secure soft starting and stopping even for the most demanding applications, while reducing mechanical wear and fluid shocks in hydraulic applications.

ATS480 features include:

- Sized for normal duty and heavy duty applications
- Controlled acceleration thanks to TCS, the original torque control system
- Controlled deceleration thanks to TCS, the original torque control system
- Efficient dynamic braking and DC injection down to zero speed to stop large inertia application
- Up to 700% motor current starting without tripping
- Boost function to override locked shaft, friction
- Smoke extraction
- Cascade

EcoStruxure Plant integration

The association of Altivar Soft Starter ATS480 with Schneider Electric automation control systems like EcoStruxure Process Expert (for hybrid systems) offers a high-performance, global automation and motor control solution with optimized total cost of ownership (TCO).

The solution provides operational integrity for people, processes, and assets, with improved maintenance support to help reduce downtime and ensure operation continuity.

It offers operational insight by accessing more information to optimize the process. Based on market standards (FDT/DTM, Ethernet, etc.), it is a sustainable, scalable solution that enables processes to be adapted easily and affordably.

An integrated automation system powered by EcoStruxure offers the following benefits:

- More efficient projects
- Optimized operations

General overview

Altistart 22

Soft start/soft stop units



Altistart 22 soft start/soft stop unit offer

Presentation

Altistart 22 soft start/soft stop units support the controlled starting and stopping, via voltage and torque, of three-phase squirrel cage asynchronous motors for power ratings ranging from 4 to 400 kW.

They are supplied ready for use in standard applications with class 10 motor protection.

Altistart 22 soft start/soft stop units have been designed to meet the performance requirements of applications where ruggedness, security of personnel and equipment, and ease of setup are a priority.

The bypass function (based on a bypass contactor) has been made easier to use by integrating it into the starter. This approach suits applications where it may be necessary to bypass the starter at the end of starting in order, for example, to limit the starter's heat dissipation.

Altistart 22 soft start/soft stop units have an integrated display terminal that allows the user to change both the programming and the adjustment or monitoring parameters in order to adapt and customize the application in line with customer needs.

They also feature an integrated thermal motor protection function as well as machine monitoring functionality, and offer immediate installation setup capability using SoMove setup software.

Applications

The integrated functions of Altistart 22 soft start/soft stop units are compatible with the more common types of application found in the construction, infrastructure, or industrial sectors:

- centrifugal pumps, piston pumps
- fans
- screw compressors
- material handling (conveyors, etc.)
- specialist machinery (agitators, mixers, centrifuges)

Altistart 22 soft start/soft stop units offer a truly cost-effective solution by providing:

- a reduction in installation costs through optimum product sizes, integrated bypass function, and faster wiring time
- a reduction in the stress associated with electrical distribution through fewer current peaks and line voltage drops caused by motor starting
- a reduction in machine running costs through reduced mechanical stress

The three phases of the motor windings are controlled to help maintain performance, whatever the situation (with or without load, any voltage or power range, etc.).

Conformity to standards

Description	Performance	
Conducted and radiated emissions	Conforming to IEC 60947-4-2	Class A
Vibration resistance	Conforming to IEC 60068-2-6	1.5 mm/0.06 in. from 2 to 13 Hz 1 gn from 13 to 200 Hz
Shock resistance	Conforming to IEC 60068-2-27	15 gn for 11 ms
Maximum ambient pollution	Conforming to IEC 60664-1	Degree 2
Relative humidity	Conforming to IEC 60068-2-3	95% non-condensing, no dripping water
Degree of protection	For ATS22D17...C11	IP 20 (IP 00 if no connection)
	For ATS22C14...C59	IP 00



Altistart 01

Soft starters for asynchronous motors



Presentation

The Altistart 01 soft starter operates either as a torque limiter on starting, or as a soft start/soft stop unit for asynchronous motors.

Using the Altistart 01 starter enhances the starting performance of asynchronous motors by allowing them to start gradually, smoothly, and in a controlled manner. It helps to prevent mechanical shocks, which cause wear and tear, and subsequent maintenance work and production downtime.

The Altistart U01 limits the starting torque and current peaks on starting on machines that do not require a high starting torque.

It is designed for the following simple applications:

- conveyors
- conveyor belts
- pumps
- fans
- compressors
- automatic doors and gates
- small cranes
- belt-driven machinery, etc.

The Altistart 01 is compact, easy to install, and can be mounted side-by-side^[1]. It complies with standards IEC/EN 60947-4-2, and carries UL, CSA, C-Tick, and CCC certifications, and e marking.

The Altistart 01 soft start/soft stop unit offer comprises 3 ranges:

- **ATS01N1●●●** soft starters
 - These control one phase of the motor power supply (single-phase or three-phase) to limit the starting torque.
 - They feature an internal bypass relay.
 - Motor power ratings range from 0.37 kW to 11 kW.
 - Motor supply voltages range from 110 V to 480 V, 50/60 Hz. An external power supply is required for controlling the starter.
 - A contactor is always required to shut off power to the motor.
- **ATS01N2●●●** soft start/soft stop units
 - These control two phases of the motor power supply to limit the starting current and for deceleration.
 - They feature an internal bypass relay.
 - Motor power ratings range from 0.75 kW to 15 kW^[2].
 - The motor supply voltages are as follows: 230 V, 400 V, and 480 V, 50/60 Hz.

The use of a line contactor is not necessary on machines where electrical isolation is not required.

[1] Side-By-Side Conditions:

The maximum starts per hour are 2 under following worst case conditions:

Ramp-up time: 10 s

Motor current 5x rated softstarter current

Ambient temperature 40°C

Applications with shorter ramp-up times and/or lower motor current and/or lower ambient temperature the cycle time can be increased.

E.g. ramp-up time 5 s -> starts per hour are 4 or motor current 3x Ie -> starts per hour are 4

For stronger conditions 15 mm distance are necessary.

[1] Please pay attention and consider for the operation of IE3 motors while dimensioning of softstarters the resulting higher starting currents.

For the use of IE3 motors it is needed to dimension and design the softstarters one size higher.

Altistart 01

Soft starters for asynchronous motors

Description



- Altistart 01 soft starters (ATS01N1ppp) are equipped with:
 - a potentiometer for setting the starting time
 - a potentiometer for adjusting the starting voltage threshold according to the motor load
 - 2 inputs:
 - 1 x 24 V c input or 1 x 110...240 V a input for powering the control part that controls the motor

- Altistart 01 soft start/soft stop units (ATS01N2ppp) are equipped with:
 - a potentiometer for setting the starting time
 - a potentiometer for setting the deceleration time
 - a potentiometer for adjusting the starting voltage threshold according to the motor load
 - 1 green LED to indicate that the unit is powered up
 - 1 yellow LED to indicate that the motor is powered at nominal voltage, if it is connected to the starter
 - a connector for:
 - 2 logic inputs for Run/Stop commands
 - 1 logic input for the BOOST function
 - 1 logic output to indicate the end of starting
 - 1 relay output to indicate the motor has reached a standstill at the end of the deceleration stage .

Equivalence table for contact references

Functions	ATS01N2●●LU/QN/RT
Relay outputs	R1A
	R1C
External power supply 0 V	C0M
Stop command	LI1
Run command	LI2
Control section power supply	LI + (+ 24 V positive logic)
BOOST	BOOST
End of starting	LO1
115 V external power supply	-

- A
- B
- C
- D
- E
- F
- G
- H
- I
- J

Market segments		
	Simple machines	
Applications		
	Simple starting	Simple starting and stopping
		
Characteristics		
Operational voltage range Ue (V)	110...480	200...480
Operational current range Ie (A)	3...25	6...32
Power range	For 50...60Hz line supply (kW/HP)	
Single-phase 110...230 V (kW)	0.37...11/0.5...15	0.75...15/1...20
Three-phase 200...240 V (kW/HP)	0.37...2.2	–
Three-phase 200...480 V (kW/HP)	–	0.75...7.5/1...10
Three-phase 208 V (HP)	0.37...11/0.5...15	–
Three-phase 230...240 V (kW/HP)	–	–
Three-phase 380...440 V (kW)	–	–
Three-phase 380...440 V (HP)	1.1...11	1.5...15
Three-phase 460...480 V (HP)	0.5...15	2...20
Three-phase 500...525 V (kW)	–	–
Three-phase 575 V (HP)	–	–
Three-phase 660...690 V (kW)	–	–
Motor control		
Operating cycle	–	–
Current limiting	–	–
Boost	–	–
Type of control	Configurable voltage ramp	
Deceleration	Voltage ramp	
Braking	–	–
Number of controlled phases	1	2
Connection inside the delta	–	–
Bypass	Integrated	
Functions		
	Thermal protections	External
	Other protections	–
	Pre-heating	–
	Smoke extraction	–
	Multi-motor cascade	–
	Second motor set	–
Communication	Embedded	–
	Option modules	–
Communication and runtime tools	2 potentiometers	3 potentiometers
Number of I/O		
Analog inputs	–	–
Digital inputs	–	3
Analog outputs	–	–
Digital outputs	–	1
Relay outputs	–	1
Standards and certifications		
	IEC/EN 60947-4-2 CE, UL, CSA, C-Tick, and CCC	
References		
	ATS01N1●●●●	ATS01N2●●●●

Industrial machines		Process and infrastructures, demanding machines	
Simple starting and stopping for pumps and fans		Controlled starting and stopping for pumps, fans, compressors, mixers, crushers, conveyors	
			
230...440	208...600	208...690	208...690
17...590	17...590	17...1200	17...1200
4...355	4...400/3...500	4...900/3...1200	4...900/3...1200
–	–	–	–
–	–	–	–
–	3...150	3...400	3...400
4...160/–	4...160/5...200	4...355/5...450	4...355/5...450
7.5...355	7.5...355	7.5...710	7.5...710
–	10...400	10...1000	10...1000
–	9...400	9...800	9...800
–	15...500	15...1200	15...1200
–	–	11...900	11...900
Normal duty		Normal duty and heavy duty	
350% current rating		500% current rating (700% rated motor current)	
Yes		Yes	
Configurable voltage ramp		Torque control (TCS = torque control system), voltage control	
Voltage ramp		Torque ramp	
–		Yes	
3	3	3	
Yes	–	Yes	
Integrated		External with soft starter optimization or without bypass	
Electronic embedded, or with PTC		Electronic embedded, with PTC, or with PT100 2- or 3-wire probes	
Underload, overload, motor phase loss, line phase inversion, excessive acceleration time, current overload, ground leakage		Underload, overload, motor phase loss, line phase inversion, overcurrent, excessive acceleration time, current overload, ground leakage	
–		Yes	
–		Yes	
–		Yes	
Yes		Yes	
Modbus serial link		Modbus serial link	
–		Modbus TCP, EtherNet/IP, PROFINET, PROFIBUS DP V1, CANopen daisy chain, SUB-D, and screw terminal block	
7-segment display, SoMove software		Plain text display terminal, graphic display terminal (option), DTM (device type manager), SoMove software	
1 PTC probe		PTC or PT100 2- or 3-wire probe	
3		4	
–		1	
–		2	
2		3	
IEC/EN 60947-4-2, EMC class A		IEC/EN 60947-4-2, EMC class A and B	
CE, UL, CSA, C-Tick, GOST, CCC		CE, cULus, UKCA, CCC, RCM, EAC, DNV, ABS, BV, CCS, REACH, RoHS	
ATS22●●●Q	ATS22●●●S6p	ATS480●●●Y	

- A
- B
- C
- D
- E
- F
- G
- H
- I
- J



> Altivar Machine Catalogues



Altivar 12



ATV320



ATV340

> Altivar Building Catalogues



Altivar 212

> Altivar Process Catalogues



ATV600



ATV900

> Altivar Soft Starters Catalogues



ATS480



Altistart 22



Altistart 01



Learn more about Altivar variable speed drives and soft starters range here



Offer

Scan or click on QR code

If you need more details about product references and availability, please check your local Schneider Electric contact <https://www.se.com/ww/en/work/support/country-selector/contact-us.jsp>

Control and signaling, Automation relays & Power supply

Harmony

Push buttons
 XB4 E-287
 XB5 E-288
 XB7 E-290

Cam switches
 Harmony K..... E-292

Tower lights
 XVU..... E-294

Control and time relays E-298
 Control relays..... E-299
 Timer relays E-310
 Electromechanical relays..... E-314
 Solid State relays E-322

Modicon Power Supply

ABLM Modular power supply E-334
 ABLS Optimized power supply E-334

Lineryg

Lineryg TR Terminal blocks..... E-338



Harmony

- A
- B
- C
- D
- E
- F
- G
- H
- I
- J



Push buttons, Cam switches and signaling units

Improved reliability of panels, machines, and processes

- Sealing effectiveness rated up to IP66, IP67, IP68, IP69, IP69K, and type 4X
- High impact resistance up to IK06 rating
- Operating temperature ranging from -40 to +70°C/-40 to +158°F
- Compliance with international standards (IEC, UL, CCC, EAC, JIS)
- Marine certified (BV, LROS, BDNV, GL).

High electrical performance

- Contacts and heads designed to prevent vibration, helping to ensure secure mounting and wiring
 - Choose from standard, low-load, and high-power electrical contacts.

Lower maintenance

- Harmony push buttons are designed to perform up to 10 million operations
 - This represents more than 1,000 operations a day for 27 years.



[SEE THE VIDEO](#)

IP69

Robust performance even in harsh environments

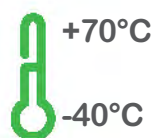

Harmony Push buttons XB4 metal



Harmony XB4 range of control and signaling units for Ø 22 mm/0.866 in. mounting



Harmony XB4 flush mounted control and signaling units for Ø 30 mm/1.181 in mounting

Presentation

The Harmony® XB4 metal range of modular control and signaling units combines simplicity of installation, flexibility, and robustness. It meets the requirements of the majority of industrial applications. These units are either available as complete products or separate components for customer assembly.

This range includes:

- Push buttons, selector/key switches, Emergency stop functions, and multiple-headed push buttons designed for parameter settings, adjustments, and start/stop control of machines and installations
- Pilot lights, illuminated push buttons, illuminated selector switches, and illuminated Emergency stop functions designed for visual signaling.
- Various accessories including:
 - Flush mounting kits:
 - redesigned, improving the look of the control panel
 - quick and easy installation in a 30.5 mm/1.20 in. hole making it compatible with 22 mm/0.87 in. devices
 - a cost-effective solution, as the control devices and the operating modes of the machine do not change.
 - Other accessories: protective covers, legends and legend holders, push button caps, boots, bulbs, etc.

The push button and switch control offer (illuminated and non-illuminated) is both broad and comprehensive:

- Push buttons, spring return with flush push, projecting push, recessed push, booted flush push, or mushroom head
- Emergency stop push buttons with 3 types of head: push-pull, turn to release, and key release
- Pilot lights and illuminated push buttons with Universal LED and BA 9s base fitting bulbs
- Selector switches with different types of operator: standard handle, long handle, knurled knob, or key
- Choice of heads: circular, double-head/triple-head rectangular, or toggle
- Colors of push: white, black, green, orange, blue, red, or yellow
- Connection type: screw clamp connector, Faston connector, spring terminal, or for printed circuit board
- Contact blocks for general purpose or specific applications (low current, standard, or high power switching)
- Choice of heads to meet the majority of industrial needs: from the most basic push buttons and pilot lights, to functions meeting modern machine requirements, such as USB & RJ45 ports
- Wide choice of accessories and spare parts
- Other specific functions: complete potentiometer, hour counters, annunciator, or joystick controllers.

Innovative complementary offers are also available:

- Control and signaling units for severe applications
- Wireless and batteryless push buttons
- Biometric switches.

Environment

The performance of the Harmony XB4 range meets some of the most demanding international standards and approvals:

- Certified and approved for meeting requirements throughout all continents: EN/IEC, CE marking, UL, CSA, CCC, EAC, JIS, NEMA, and marine approvals
- Protection against ingress of solid objects, dust, and water: IP66, IP67, IP69, IP69K, type 4X
- Operating temperature range from -40°C to +70°C/-40°F to +158°F for outdoor applications
- Shock protection level up to IK06
- High vibration resistance with shakeproof connection screws (periodic retightening unnecessary).

Harmony Push buttons XB5, plastic

A



B



C



D



Harmony XB5 range of control and signaling units for Ø 22 mm/0.866 in mounting

E



F



G



Harmony XB5 flush mounted control and signaling units for Ø 30 mm/1.181 in mounting

H

I

J

Presentation

The Harmony XB5 plastic range of modular control and signaling units combines simplicity of installation, flexibility, and robustness. It meets the requirements of the majority of industrial applications. These units are either complete products or separate components for customer assembly.

This range includes:

- Push buttons, selector/key switches, Emergency stop functions, and multiple-headed push buttons designed for parameter settings, adjustments, and start/stop control of machines and installations
- Pilot lights, illuminated push buttons, illuminated selector switches, and illuminated Emergency stop functions designed for visual signaling
- Flush mounting heads for Ø 30 mm/1.181 in. mounting and flush mounting kit accessories combined to offer a modern look to the control panel
- Harmony basic and configurable display offers data visualization
- Various accessories including protective covers, legends and legend holders, push button caps, boots, bulbs, etc.

The push button and switch control offer (illuminated and non-illuminated) is both broad and comprehensive:

- Push buttons, spring return with flush push, projecting push, recessed push, booted flush push, or mushroom head
- Emergency stop push buttons with three types of head: push-pull, turn to release, and key release
- Pilot lights and illuminated push buttons with universal LED and BA 9s base fitting bulbs
- Selector switches with different types of operator: standard handle, long handle, knurled knob, or key
- Choice of heads: circular, rectangular, double-head/triple-head rectangular, or toggle
- Colors of push: white, black, green, orange, blue, red, or yellow
- Connection type: screw clamp connector, faston connector, spring terminal, or for printed circuit board
- Contact blocks for general purpose or specific applications (low current, standard or high-power switching)
- Choice of heads to meet the majority of industrial needs, from the most basic push buttons and pilot lights, to functions meeting modern machine requirements, such as USB & RJ45 ports
- Wide choice of accessories and spare parts
- Configurable display for simple machine function
- Other specific functions: complete potentiometer, hour counters, annunciator, or joystick controllers.

Innovative complementary offers are also available:

- Control and signaling units for severe applications
- Wireless and batteryless push buttons
- Biometric switches.

Harmony Push buttons XB5, plastic



Harmony Digital Panel meter

Basic display: Harmony Digital Panel meter

Harmony XBH is a digital panel meter for mounting on a control panel or directly on the front of a machine. With the simple 4-digit display, it is easy to view process data from long distances. The display is easy to mount directly in a $\varnothing 22$ mm/ 0.866 in. hole and is supplied directly from the measuring loop. It has 2 digital outputs for setting a high and low limit and can be configured using the blue and red buttons on the side of the housing. An external alarm can be connected to the panel meter for providing an additional alert in the event of reaching a high or low limit threshold. Harmony XBH panel meters have an IP65 protection rating and the operating temperature can be between -20 and $60^{\circ}\text{C}/-4$ and 140°F .

The following settings can be adjusted using the configuration buttons:

- Minimum and maximum value of the input signal
- Number of decimals
- Number of measurements per second
- LOW limit and HIGH limit output threshold
- LOW limit and HIGH limit hysteresis and time delay
- Password protection for the configuration.

Environment

The performance of the Harmony XB5 range meets some of the most demanding international standards and approvals:

- Certified and approved for meeting requirements worldwide: EN/IEC, CE marking, UL, CSA, CCC, EAC, JIS, NEMA, and marine approvals
- Protection against the ingress of solid foreign objects, dust, and water: IP66, IP67, IP69, IP69K, type 4X
- Operating temperature range from -40°C to $+70^{\circ}\text{C}/-40^{\circ}\text{F}$ to $+158^{\circ}\text{F}$ for outdoor applications
- High chemical robustness
- Shock protection level up to IK03
- High vibration resistance with shakeproof connection screws (periodic retightening unnecessary).

A

B

C

D

E

F

G

H

I

J

Harmony Push buttons XB7, monolithic

Control and signaling units Ø 22



Presentation

The Harmony® XB7 range of plastic control and signaling units is a monolithic range designed for use in the industrial, tertiary and building sectors. It is simple to use and quick to install.

This range includes:

- Push buttons and switches designed for Start/Stop control of machines and installations, adjustment and parametering (contact functions): Push buttons, selector/key switches, Emergency stop or Emergency switching off push buttons
- Pilot lights designed for visual signaling (signaling functions)
- Illuminated push buttons designed for control and signaling (contact functions + signaling functions)
- The range comprises complete units, with round plastic bezel, and 6 pilot light.

The push button and switch control offer comprises:

- Flush and projecting spring return push buttons, with or without marking
- Flush latching push buttons, without marking
- Projecting spring return or latching illuminated push buttons
- Emergency stop trigger action and mechanically latching mushroom head push buttons (conforming to standards EN/IEC 60204-1 and EN/ISO 13850)
- Emergency switching off mechanically latching mushroom head push buttons (conforming to standard IEC 60364-5-53)
- Selector switches, with standard black handle, and key switches
- Legends and legend holders
- Accessories and spare parts.

The pilot light signaling offer includes:

- Pilot lights with integral LED
- Pilot lights for BA 9s base fitting bulbs.

The two types of pilot lights are for direct supply or with resistor.

Installation

Harmony XB7 products are both simple and quick to install:

- Mounting by single installer
- Fixing by a single locking nut.

Two types of connection are available:

- Screw clamp terminals
- Faston connectors (only for pilot lights).

Environment

The performance features of the XB7 range meet the following specifications:

- International standards and approvals:
 - For the entire range: EN/IEC 60947-1, EN/IEC 60947-5-1, EN/IEC 60947-5-4, UL 508, CSA C22-2 n°. 14, GB 14048.5
 - For Emergency stop push buttons: EN/IEC 60947-5-5, EN/ISO 13850 and EN/IEC 60204-1
 - For Emergency switching off push buttons: EN/IEC 60364-5-53.
- International certifications: UL, CSA, CCC, GOST
- Degrees of protection:
 - Front face: IP65 (IP54 for Emergency switching off push buttons)
 - Rear face: IP20 (protection against direct contact).

For more technical information, please refer to our website www.se.com

Harmony Push buttons XB4, XB5 and XB7

Type	Push buttons, selector switches, and pilot lights		
			
Type references	XB4	XB5	XB7
Description of range			
	<ul style="list-style-type: none"> ■ Push buttons ■ Multiple-headed push buttons ■ Emergency Stop push buttons ■ Selector switches and key switches ■ Illuminated push buttons ■ Pilot lights ■ Flush mounted push buttons, selector switches, and pilot lights^[1] 	<ul style="list-style-type: none"> ■ Push buttons ■ Emergency Stop and Emergency switching off push buttons ■ Selector switches and key switches ■ Illuminated push buttons ■ Pilot lights 	
Features			
Products	Complete units or sub-assemblies (body + head)	Monolithic	
Bezel	Metal, chromium plated, or black	Double insulated	Double insulated, dark gray (or white for pilot lights)
Shape of head	Circular	Circular	Circular
Drilling or cut-out for fixing			
	<ul style="list-style-type: none"> ■ Ø 22 mm/0.866 in. ■ Ø 30 mm/1.181 in. (for flush mounted control and signaling units) 		Ø 22 mm/0.866 in.
Degree of protection			
Conforming to IEC 60529	IP66, IP67, IP69, and IP69K	<ul style="list-style-type: none"> ■ IP65 (control buttons and pilot lights) ■ IP54 (Emergency switching off push buttons) 	
Conforming to UL 508 and CSA C22-2 No. 14	Enclosure type 4, 4X, and 13	Enclosure type 3 (push buttons and Emergency stop) and 4 (pilot lights)	
Cabling			
	<ul style="list-style-type: none"> ■ Spring clamp terminal connections ■ Screw clamp terminal connections ■ Faston connectors ■ Connector with adapter for printed circuit board 	<ul style="list-style-type: none"> ■ Screw and captive clamp terminal connections ■ Faston clip connections (pilot lights) 	
Mounting			
Panel thickness	1...6 mm/0.039...0.236 in.		1...6 mm/0.039...0.236 in.

[1] Flush mounted control and signaling units are available for Harmony XB4 and XB5 ranges only.



Learn more about Harmony Push buttons range here



Offer



Catalogue XB4



Catalogue XB5



Catalogue XB7

Scan or click on QR code

If you need more details about product references and availability, please check your local Schneider Electric contact <https://www.se.com/ww/en/work/support/country-selector/contact-us.jsp>



Cam switches

Harmony Type K

A
B
C
D
E
F
G
H
I
J

Type	Type K10	Type K1/K2
		
Cam switch model	K10●	K1●
Applications	Used in building control panels and consoles, type K cam switches allow control of processes and utilities in industry and buildings and direct control for simple machines.	
Functions		
Off-On/On-Off switches	1 to 4-pole	1 to 6-pole
Stepping switches	2 to 4-position, 1 and 2-pole	2 to 12-position, 1 to 4-pole
Changeover switches	1 to 4-pole	1 to 5-pole
Measurement switches	Voltmeter and ammeter	Voltmeter and ammeter
Reversing switches	-	2 and 3-pole
Reversing star-delta switches	-	-
Pole change switches	-	2 and 3-speed
Characteristics		
Conventional rated thermal current (I _{th})	10 A	12 A
Rated insulation voltage (U _i)	440 V	690 V
Electrical operating characteristics	<ul style="list-style-type: none"> ■ AC-15 - A300 ■ 240 V - 3 A 	<ul style="list-style-type: none"> ■ AC-3 - 3-phase ■ 230 V - 1.1 kW - 4.6 A ■ AC-15 ■ 230 V - 3 A
Front plate degree of protection	IP65	<ul style="list-style-type: none"> ■ IP40 ■ IP65 (with seal)
Product composition	Complete switches	<ul style="list-style-type: none"> ■ Complete switches ■ Adaptable sub-assemblies ■ Special products (Consult our Customer Care Centre)
Compatibility	Ø 16 and Ø 22 control and signaling units	Ø 22 control and signaling units
Fixing	Front mounting Single Ø 16 or Ø 22 hole	<ul style="list-style-type: none"> ■ Multi-fixing ■ Single Ø 22 hole
	Rear mounting	Screw fixing, 4 holes on 36 mm/1.42 in. centres
Front plate dimensions (mm)	30 x 30 mm/1.18 x 1.18 in.	<ul style="list-style-type: none"> ■ 45 x 45 mm/1.77 x 1.77 in. ■ 60 x 60 mm/2.36 x 2.36 in. (adaptable sub-assemblies)
Operating heads	<ul style="list-style-type: none"> ■ Black standard handle ■ Metallic legend, black marking 	<ul style="list-style-type: none"> ■ Black and red standard and long handles ■ Key operator ■ Metallic head ■ Metallic legend with black marking or black legend with white marking
Approvals	<ul style="list-style-type: none"> ■ cULus ■ EN/IEC 60947-3 ■ EN/IEC 60947-5-1 	<ul style="list-style-type: none"> ■ UL-CSA ■ EN/IEC 60947-3 ■ EN/IEC 60947-5-1

Selection guide

Cam switches

Harmony Type K

Type K30...K150



K2● K30● K50● K63● K115● K150●

1 to 6-pole	1 to 6-pole
2 to 12-position, 1 to 4-pole	-
1 to 5-pole	1 to 4-pole
-	-
2 and 3-pole	2 and 3-pole
Star-delta	Star-delta
2 and 3-speed	2-speed

20 A	32 A	50 A	63 A	115 A	150 A
690 V	690 V	690 V	690 V	690 V	690 V
<ul style="list-style-type: none"> AC-3 - 3-phase 230 V - 2.2 kW - 8.3 A AC-15 230 V - 4 A 	<ul style="list-style-type: none"> AC-3 - 3-phase 230 V - 5.5 kW AC-15 230 V - 14 A 	<ul style="list-style-type: none"> AC-3 - 3-phase 230 V - 7.5 kW AC-15 230 V - 16 A 	<ul style="list-style-type: none"> AC-3 - 3-phase 230 V - 11 kW - 	<ul style="list-style-type: none"> AC-3 - 3-phase 230 V - 15 kW - 	<ul style="list-style-type: none"> AC-3 - 3-phase 230 V - 22 kW -
<ul style="list-style-type: none"> IP40 IP65 (with seal) 	IP40				
<ul style="list-style-type: none"> Complete switches Adaptable sub-assemblies Special products (Consult our Customer Care Centre) 	Complete switches				
Ø 22 control and signaling units					
<ul style="list-style-type: none"> Multi-fixing Single Ø 22 hole 	By 4 holes on 48 mm / 1.89 in. centres			By 4 holes on 68 mm / 2.68 in. centres	
Screw fixing, 4 holes on 36 mm / 1.42 in. centres	Screw fixing, 4 holes on 48 mm / 1.89 in. centres			Screw fixing, 4 holes on 68 mm / 2.68 in. centres	
<ul style="list-style-type: none"> 45 x 45 mm / 1.77 x 1.77 in. 60 x 60 mm / 2.36 x 2.36 in. (adaptable sub-assemblies) 	64 x 64 mm / 2.52 x 2.52 in.			88 x 88 mm / 3.46 x 3.46 in.	
<ul style="list-style-type: none"> Black and red standard and long handles Key operator Metallic head Metallic legend with black marking or black legend with white marking 	<ul style="list-style-type: none"> Black standard handle Metallic legend, black marking 				
<ul style="list-style-type: none"> UL-CSA EN/IEC 60947-3 EN/IEC 60947-5-1 	<ul style="list-style-type: none"> cULus EN/IEC 60947-3 				



Learn more about
Harmony K
range here



Offer



Catalogue

Scan or
click on
QR code

If you need more details about product references and availability, please check your local Schneider Electric contact <https://www.se.com/ww/en/work/support/country-selector/contact-us.jsp>

General overview

Harmony Signaling units type XVU Ø 60

Modular tower lights

Harmony XVU modular tower light with innovative features

The Harmony XVU modular range of tower lights are 360° pilot lights and commonly used signaling product for a wide range of applications. These tower lights are visual and audible signaling units that comes with a combination of innovative features, high performance and simplicity.

High performance light

- True color and homogeneity light
- Improved visibility
- LED super-bright flash with long life performance.

Customized voice message

- A free of charge configuration software allows to customize the audible signals via SD card
- The sound unit plays voice message when customer inputs PLC signals
- Adjustable volume up to 86 dB at 1 m/3.281 ft.

Simplified wiring

- Pulse signal units use one signal wire to define different types of signaling
- Flexible and configurable light patterns
- Up to 256 different combination of audible and visual signals
- Up to 16 different combination of visual signals (color combination)
- One pulse signal multi-color unit can be implemented instead of several single color illuminated units
- Reduction in 1/0 wires to connect PLC with tower light
- CE, UL, CSA, and PCT certified.

Aesthetic design

- Available in black and metallic silver body
- Reduced diameter (Ø 60 mm/2.362 in.) makes them suitable for small equipment
- Aesthetic design distinguishes them from other tower lights.



The mix of homogeneity light and true color improves the aesthetic of the tower light



Playlist Builder

Configuration of audible signal via Playlist Builder software



Addition of pulse signal unit to the existing range of Harmony XVU tower lights



> Super bright LED technology

> Pulse signal unit enables up to 75% reduction in wiring

Harmony Signaling units type XVU Ø 60 Modular tower lights



Simplicity

- Simple and easy assembly without use of any tools
- Convenient mounting option with: direct mounting, pole mounting and three-in-one adjustable wall mounting.

Good resistance

- Resistant to dust and water and are UL/CSA compliant
- The illuminated units have IP65 degree of protection, and are resistant to cutting oil
- Audible units have IP54 degree of protection.



With the indicator marks, the units are simple and quick to assemble

IP65

IP54

Degree of protection and compliance



+ _____
> User-friendly



Harmony Signaling units type XV

Signaling solutions

- A
- B
- C
- D
- E
- F
- G
- H
- I
- J

Harmony type XV	Modular tower lights										
											
Type references XVU											
Type of products	Tower lights for customer assembly of up to 5 units										
Diameter	Ø 60 mm/2.362 in.										
Degree of protection conforming to IEC 60529	<ul style="list-style-type: none"> ■ IP65 for illuminated units ■ IP54 for audible units ■ IP55 for flexible mounting unit 										
Type of signalling	<table border="1" style="width: 100%; border-collapse: collapse;"> <tr><td>Steady</td><td>Yes</td></tr> <tr><td>Flashing</td><td>Yes</td></tr> <tr><td>High flashing</td><td>Yes</td></tr> <tr><td>"Flash"</td><td>-</td></tr> <tr><td>Sound</td><td>Yes (buzzer or editable voice)</td></tr> </table>	Steady	Yes	Flashing	Yes	High flashing	Yes	"Flash"	-	Sound	Yes (buzzer or editable voice)
Steady	Yes										
Flashing	Yes										
High flashing	Yes										
"Flash"	-										
Sound	Yes (buzzer or editable voice)										
Light sources	<table border="1" style="width: 100%; border-collapse: collapse;"> <tr><td>Incandescent bulb</td><td>-</td></tr> <tr><td>LED bulb</td><td>-</td></tr> <tr><td>Integral LED</td><td>Yes</td></tr> <tr><td>"Flash" discharge tube</td><td>-</td></tr> <tr><td>Halogen bulb</td><td>-</td></tr> </table>	Incandescent bulb	-	LED bulb	-	Integral LED	Yes	"Flash" discharge tube	-	Halogen bulb	-
Incandescent bulb	-										
LED bulb	-										
Integral LED	Yes										
"Flash" discharge tube	-										
Halogen bulb	-										
Colors of illuminated units	<ul style="list-style-type: none"> ■ Green ■ Red ■ Orange ■ Blue ■ White ■ Yellow 										
Connection	Spring cage connection terminals										
Support panel drilling or cut-out	<ul style="list-style-type: none"> ■ Mounting on support tube and adjustable support tube: 4 x Ø 6 mm/0.236 in. ■ Flexible wall mounting: 3 x Ø 5 mm/0.197 in. ■ Direct mounting: <ul style="list-style-type: none"> □ 2 x Ø 5 mm/0.197 in. □ 3 x Ø 5 mm/0.197 in. □ 4 x Ø 5 mm/0.197 in. ■ Mounting on bracket: 2 x Ø 9 mm/0.354 in. 										



Learn more about
Harmony XVU
range here



Offer



Catalogue

Scan or
click on
QR code

If you need more details about product references and availability, please check your local Schneider Electric contact <https://www.se.com/ww/en/work/support/country-selector/contact-us.jsp>



Harmony Control and time relays



Enhance operational efficiency and optimize equipment availability with Harmony, our widest range of relays. Harmony relays are designed, manufactured, and tested to meet your needs for both wired logic functions and PLC Interfaces.

> Control relays



> Timer relays



> Electromechanical relays



> Solid state relays



Near Field Communication and conventional Control relays

Harmony Control relays monitor and detect abnormal operating conditions concerning phase, current, voltage, frequency, speed, or temperature. The relays inform users of abnormal conditions, and allow them to initiate the necessary corrective actions before serious and costly breakdowns can occur. By monitoring energy network statuses, they enable both electrical and mechanical load control.



They are suitable for a wide range of applications:

- Hoisting: construction cranes, harbor cranes
- Packaging: motor voltage, current overload
- Lifts: construction lifts, passenger lifts, escalators
- Textile: motor voltage, current overload
- Water: liquid level on water tank at water and waste water recycling plant.

Depending on the product model, control relays are categorized into 8 product families:

- 3-phase control
- Current control
- Voltage control
- Frequency control
- Speed control
- Lift temperature control
- Level control
- Pump control.

Harmony Control relay functions

Monitoring

Control relays monitor physical and electrical values. They measure variable signals such as phase (presence, sequence and symmetry), voltage, current, and frequency. They also control liquid levels and process operating rates.

Informing

Control device outputs provide users with electrical information. In addition, setting faults are signaled by simultaneous flashing of all LEDs.

Protecting

Integrated in the control circuits of automated systems, they enable automatic shutdown management and provide fault information, thus protecting the equipment.

Managing

When the power is switched on, the control relays are inhibited to enable correct measurement circuit setting. The outputs operate with positive logic, the contact or contacts being closed under normal conditions and opening as soon as a fault or power supply loss is detected.

Commissioning

When the diagnostic button is used, the downstream circuit can be closed immediately without sending a fault input signal to the relays. This shortens the testing time during commissioning and troubleshooting.

A

B

C

D

E

F

G

H

I

J

General overview

Harmony Control relays

A

Harmony Control relay with unique design and features

- Compact modular sizes: 17.5 mm/0.69 in., 22.5 mm/0.88 in., 35 mm/1.38 in.
- Adapted for industrial and building control panels
- True RMS measurement that minimizes the possibility of unexpected trips from highly polluted networks (except RM17TG and RM22TG)
- Diagnostic button to check the downstream circuit immediately and reduce commissioning and troubleshooting time^[1]
- IP50 lead-sealable settings protection cover helps prevent dust and unintended human intervention
- Status indication by LEDs, additional dial pointer LED for easy setup in dark conditions^[1], and power "On" status indication when relay is ready to perform
- Optimization of power supplies
- Worldwide certification:



B

C

D

E

Harmony Control relay with NFC^[2] technology

Simplify product selection

One product reference with 7 control functions: Phase loss, Phase sequence, Asymmetry, Overvoltage, Undervoltage, Overfrequency, and Underfrequency.

Achieve unprecedented accuracy

- Digitized setting eliminate the need for screw driver
- Timed delay can be set by minute, second or millisecond.

Fault diagnosis

- Fault status indication by LEDs
- Real time fault analysis and Historical fault data are viewable in APP.

Superior security

4 digit password protection.



F

G

H

I

J



- > A simple approach to monitoring your equipment
- > To control your machines and processes of the future



Scan here to check out the NFC Control Relay video

NFC Control Relay:

As simple as

- 1 Install
- 2 Open app
- 3 Set parameters

[1] Available in RM35JA32MR, RM35JA32MT, and all RM22 references.

[2] Near Field Communication.

General overview

Harmony Control relays



Harmony Control relays

A
B
C
D
E
F
G
H
I
J

Type	Modular relay				
					
	RM17TG00 RM17TG20	RMNF22TB30	RM22TG20	RM17TT00	RM22TR31 RM22TR33
Application	3-phase control				
Functions	<ul style="list-style-type: none"> Phase sequence Phase loss 	With/without memory selection in the app. <ul style="list-style-type: none"> Phase sequence Phase loss Asymmetry Undervoltage Overvoltage Under-frequency Over-frequency 	<ul style="list-style-type: none"> Phase sequence Phase loss 	<ul style="list-style-type: none"> Phase sequence Phase loss 	<ul style="list-style-type: none"> Phase sequence Phase loss Overvoltage and undervoltage
Values controlled	<ul style="list-style-type: none"> 208...480 V ~ 208...440 V ~ 	208...480 V ~	208...480 V ~	208...480 V ~	<ul style="list-style-type: none"> 200...240 V ~ 380...480 V ~
Output contact rating	1 or 2 CO 5 A	2 CO 8 A (individually configurable)	2 CO 8 A	1 CO 5 A	2 CO 8 A
Supply voltage	Self-powered	<ul style="list-style-type: none"> 208...480 V ~ line to line 120...277 V ~ line to neutral 	Self-powered		
Time delay	-	0.1s...60 min	-		0.1...30 s
Size (mm/in.)	17.5/0.69	22.5/0.885	22.5/0.885	17.5/0.69	22.5/0.885

Selection guide Harmony Control relays



RM17TU00



RM22TU21
RM22TU23



RM17TA00



RM22TA31
RM22TA33



RM17TE00
RM35TF30



RM17UB310
RM35UB330
RM35UB3N30



RM35TM50MW
RM35TM250MW

<ul style="list-style-type: none"> Phase sequence Phase loss Undervoltage 	<ul style="list-style-type: none"> Phase sequence Phase loss Asymmetry 	<ul style="list-style-type: none"> Phase sequence Phase loss Asymmetry 	<ul style="list-style-type: none"> Phase sequence Phase loss Asymmetry 	<ul style="list-style-type: none"> Phase sequence Phase loss Asymmetry Overtoltage and undervoltage 	<ul style="list-style-type: none"> Overtoltage and undervoltage between phases Overtoltage and undervoltage between phases and neutral Absence of neutral/phase 	<ul style="list-style-type: none"> Phase sequence Phase loss Motor temperature
208...480 V ~	<ul style="list-style-type: none"> 200...240 V ~ 380...480 V ~ 	208...480 V ~	<ul style="list-style-type: none"> 200...240 V ~ 380...480 V ~ 	<ul style="list-style-type: none"> 208...480 V ~ 220...480 V ~ 	<ul style="list-style-type: none"> 220...480 V ~ 208...480 V ~ 120...277 V ~ 	<ul style="list-style-type: none"> 208...480 V ~ Motor temperature: PTC probe resistance 15 Ω to 3100 Ω
1 CO 5A	2 CO 8A	1 CO 5A	2 CO 8A	1 or 2 CO 5A	1 CO or 2 CO 5A	2 NO 5A
Self-powered						24-240 V ~
0.1...10 s	–	0.1...10 s	0.1...30 s	0.1...10 s	0.3...30 s	–
17.5/0.69	22.5/0.885	17.5/0.69	22.5/0.885	17.5/0.69 or 35/1.377	17.5/0.69 or 35/1.377	35/1.377

- A
- B
- C
- D
- E
- F
- G
- H
- I
- J

Harmony Control relays

- A
- B
- C
- D
- E
- F
- G
- H
- I
- J

Type	Modular relay		
	 RM17UAS15315M	 RM17UAS14 RM17UAS16 RM17UAS15	 RM35UA11MW RM35UA12MW RM35UA13MW
Application	1-phase voltage control		
Functions	Undervoltage (without memory) Overvoltage or undervoltage (with/without memory)		
Values controlled	220 V ~	<ul style="list-style-type: none"> ■ 9...15 V ~ ■ 20...80 V ~ ■ 65...260 V ~ 	<ul style="list-style-type: none"> ■ 0.05...5 V ~ ■ 1...100 V ~ ■ 15...600 V ~
Output contact rating	1 CO 5A	1 CO 5A	2 CO 5A
Supply voltage	Self-powered	Self-powered	24...240 V ~
Time delay	3...15 min	0.1...10 s	0.3...30 s
Size (mm/in.)	17.5/0.69	17.5/0.69	35/1.377

Selection guide Harmony Control relays



RM22UA21MR
RM22UA22MR
RM22UA23MR



RM22UA31MR
RM22UA32MR
RM22UA33MR
RM22UA33MT



RM17UBE16
RM17UBE15



RM22UB34

Overvoltage (without memory)

- Overvoltage (with/without memory)
- Undervoltage (with/without memory)
- Overvoltage and undervoltage in window mode (with/without memory)

Overvoltage and undervoltage in window mode (without memory)

- 0.05...5 V \sim
- 1...100 V \sim
- 15...500 V \sim

- 0.05...5 V \sim
- 1...100 V \sim
- 15...500 V \sim

- 20...80 V \sim
- 65...260 V \sim

80...300 V \sim

2 CO 8 A

2 CO 8 A

1 CO 5 A

2 CO 8 A

24...240 V \sim

- 24...240 V \sim
- 380...415 V \sim

Self-powered

110...240 V \sim

-

0.1...30 s

0.1...10 s

0.1...30 s

22.5/0.885

22.5/0.885

17.5/0.69

22.5/0.885



Harmony Control relays

- A
- B
- C
- D
- E
- F
- G
- H
- I
- J

Type	Modular relay	
	 RM17JC00MW	 RM22JA21MR
Application	1-phase current control	
Functions	Integrated current transformer Overcurrent (without memory)	No integrated current transformer Overcurrent (without memory)
Values controlled	2...20 A	4 mA...1 A
Output contact rating	1 CO 5 A	2 CO 8 A
Supply voltage	24...240 V \sphericalangle	24...240 V \sphericalangle
Time delay	-	-
Size (mm/in.)	17.5/0.69	22.5/0.885



RM35JA31MW
RM35JA32MW



RM22JA31MR
RM35JA32MR
RM35JA32MT

- Overcurrent (with/without memory)
- Undercurrent (with/without memory)

- 2...500 mA
- 0.15...15 A

2 CO 5 A

24...240 V ~

- Inhibition time delay upon startup 1...20 s
- Time delay 0.3...30 s

35/1.377

- Overcurrent (with/without memory)
- Undercurrent (with/without memory)
- Overcurrent and undercurrent in window mode (with/without memory)

- 4 mA...1 A
- 150 mA...15 A

2 CO 8 A

- 24...240 V ~
- 380...415 V ~

0.1...30 s

22.5/0.885, 35/1.377

A

B

C

D

E

F

G

H

I

J

Harmony Control relays

A
B
C
D
E
F
G
H
I
J

Type	Modular relay			
				
	RM22LG11MR RM22LG11MT	RM35LM33MW	RM22LA32MR	RM35LV14MW
Application	Level control			
Functions	By resistive probes <ul style="list-style-type: none"> Level 1/Level 2 Fill operation Empty operation Standard sensitivity 	<ul style="list-style-type: none"> Level 1/Level 2 Fill operation Empty operation Low sensitivity Standard sensitivity High sensitivity 	<ul style="list-style-type: none"> Level 1/Level 2 Fill operation Empty operation Low sensitivity Standard sensitivity High sensitivity 	By discrete sensor <ul style="list-style-type: none"> Empty or fill Input for discrete sensor AON: Contact/PNP/NPN
Values controlled	<ul style="list-style-type: none"> 5...100 kΩ 	<ul style="list-style-type: none"> 0.25...5 kΩ 5...100 kΩ 0.05...1 MΩ 	<ul style="list-style-type: none"> 0.25...5 kΩ 5...100 kΩ 0.05...1 MΩ 	–
Output contact rating	1 CO 8 A	2 CO 5 A	2 CO 8 A	1 CO 5 A
Supply voltage	<ul style="list-style-type: none"> 24...240 V ~ 380...415 V ~ 	24...240 V ~	24...240 V ~	24...240 V ~
Time delay	–	0.1...5 s	0.1...30 s	0.1...5 s
Size (mm/in.)	22.5/0.885	35/1.377	22.5/0.885	35/1.377



RM17TU00	RM22TU21 RM22TU23	RM17TA00	RM22TA31 RM22TA33	RM17TE00 RM35TF30
Pump control	Frequency control	Speed control	Temperature control for elevator machine rooms and 3-phase supplies	
3-phase and 1-phase <ul style="list-style-type: none"> Overcurrent and undercurrent Phase sequence on 3-phase supply Phase loss on 3-phase supply 	Over-frequency and under-frequency (with/without memory)	Over or under operating rate/speed (with/without memory)	<ul style="list-style-type: none"> Elevator Machine room temperature Over temperature and under temperature 	<ul style="list-style-type: none"> Elevator Machine room temperature Over temperature and under temperature Phase loss and phase sequence
<ul style="list-style-type: none"> Current: 1...10 A 3-phase 208...480 V ~ 1-phase 230 V ~ 	<ul style="list-style-type: none"> Mains supply: 50 or 60 Hz High threshold: -2...+10 Hz Low threshold: -10...+2 Hz 	Time controlled between pulses: <ul style="list-style-type: none"> 0.05...0.5 s, 0.1...1 s, 0.5...5 s, 1...10 s 0.1...1 min, 0.5...5 min, 1...10 min 	Temperature: <ul style="list-style-type: none"> Low threshold: -1...11°C High threshold: 34...46°C 	Temperature: <ul style="list-style-type: none"> Low threshold: -1...11°C High threshold: 34...46°C 3-phase supplies: 208...480 V ~
1 CO 5A	2 CO 5A	1 CO 5A	1 CO 5A or 2 NO 5A	2 NO 5A
<ul style="list-style-type: none"> 208...480 V ~, 3-phase 230 V ~, 1-phase 	120...277 V ~	24...240 V ~	24...240 V ~	24...240 V ~
<ul style="list-style-type: none"> Inhibition time delay upon startup 1...60 s Time delay 0.1...10 s 	0.1...10 s	Inhibition time delay upon startup 0.6...60 s	1...10 s	1...10 s
35/1.377	35/1.377	35/1.377	35/1.377	35/1.377



Learn more about Harmony Control Relays range here



Offer



Catalogue

Scan or click on QR code

If you need more details about product references and availability, please check your local Schneider Electric contact <https://www.se.com/ww/en/work/support/country-selector/contact-us.jsp>



Harmony Timer relays

Near Field Communication and conventional Timer relays



Harmony Timer are timing relays designed to time events in industrial automation systems by closing and opening contacts before, during, or after a set time period. They are designed for hard-wired logic automated systems to complement the functions of industrial programmable logic controllers (PLCs).

They are suitable for a wide range of applications:

- Machines: single machine, and industrial automation and processes
- Buildings: lighting control, access control door locks, roller shutters
- Water segment: pumping and irrigation systems
- HVAC: fans and centralized water systems.

Depending on the product model, these relays support multiple time ranges:

- Modular DIN rail mounted timing relays



RE17



RENF



RE22

The Harmony Timer relays also feature:

- Wide power supply range from 24 to 240 V \approx
- Single or multi timing ranges from 0.02 s to 999 hrs
- Screw or spring connection terminals
- Relay or solid-state output
- Conformity to IEC 61812-1 and EN 61812-1 standards
- UL, CSA, GL, RCM, EAC, CCC, and China ROHS compliance
- Easy to set up with wiring diagrams on the side of the product.

- Miniature plug-in timing relays

- Panel mounted/plug-in timing relays



REXL



RE48A

Harmony Timer relays

- Innovative, ergonomic and configurable offer with single or multifunction types

Harmony RE22 Timing relays

Modular relays with unique features

- Innovative: dial pointer LED indicator and diagnostic button to assist setup and troubleshooting
- Compact and reliable
- Energy efficient: simple to implement, operate, and maintain
- Compliance with standards and certifications
- QR code embedded in instruction sheet for easy setup.



> A complete range of reliable and flexible offers

Harmony NFC Timing relays

The NFC timing relay is designed to time events in industrial automation systems by closing or opening contacts before, during, or after a set timing period.

The mobile app, Zelio NFC created for NFC timing relay is Android enabled and can be downloaded on the phone from Google Play.

Simplify product selection

- One product reference
- 28 timing functions
- 2 outputs
- Wide range of voltage supplied (24...240 V $\overline{\text{---}}$ / \sim).

Achieve unprecedented accuracy

- Reduce error margin from 10% to 0.2%
- Timing can be set by hour, minute, second, or millisecond.

Diagnose your relay

- Read relay status
- Overwrite the output
- Manage relays without power.

Count on superior security

- Four-digit password protection without power.

Save valuable time

- Clone settings
- Store settings
- Share settings through SMS



Select Function



Select Time



Diagnose



Security setting

NFC Timing relay:

As simple as

- 1 Install
- 2 Open app
- 3 Set parameters



> World's first industrial NFC timing relay



Harmony Timer relays

- A
- B
- C
- D
- E
- F
- G
- H
- I
- J

Type	Modular and DIN rail mounted			
				
	RE17L...	RE17L...S	RE17R...	RE17R...S
Application	<p>These timing relays enable simple automation cycles to be set up using wired logic. They can also be used to complement the functions of PLCs.</p>			
Output	<p>Solid state Timing relays with solid state output reduce the amount of wiring required (wired in series). The durability of these timing relays is independent of the number of operating cycles.</p>		<p>Relay Relay outputs provide complete isolation between the supply circuit and the output. It is possible to have several output circuits.</p>	
Connection	Screw type	Spring type	Screw type	Spring type
Time ranges	<ul style="list-style-type: none"> ■ 7 ranges: <input type="checkbox"/> 1 s <input type="checkbox"/> 10 s <input type="checkbox"/> 1 min <input type="checkbox"/> 10 min <input type="checkbox"/> 1 h <input type="checkbox"/> 10 h <input type="checkbox"/> 100 h 		<p>Depending on model:</p> <ul style="list-style-type: none"> ■ 6 ranges: <input type="checkbox"/> 1 s <input type="checkbox"/> 10 s <input type="checkbox"/> 1 min <input type="checkbox"/> 10 min <input type="checkbox"/> 1 h <input type="checkbox"/> 10 h ■ 7 ranges: <input type="checkbox"/> 1 s <input type="checkbox"/> 10 s <input type="checkbox"/> 1 min <input type="checkbox"/> 10 min <input type="checkbox"/> 1 h <input type="checkbox"/> 10 h <input type="checkbox"/> 100 h 	



RENF



RE22



REXL

RE48A

A

B

C

D

E

F

G

H

I

J

Screw type

0.1 s to 999 h

Depending on model:

■ 7 ranges:

- 1 s
- 10 s
- 1 min
- 10 min
- 1 h
- 10 h
- 100 h

■ 7 ranges:

- 1 s
- 3 s
- 10 s
- 30 s
- 100 s
- 300 s
- 10 min

■ 7 ranges:

- 0.5 s
- 1 s
- 3 s
- 10 s
- 30 s
- 100 s
- 300 s

■ 1 range:

- 30 s

■ 10 ranges:

- 1 s
- 3 s
- 10 s
- 30 s
- 100 s
- 300 s
- 30 min
- 300 min
- 30 h
- 300 h

■ 7 ranges:

- 0.1 s...1 s
- 1 s...10 s
- 0.1 min...1 min
- 1 min...10 min
- 0.1 h...1 h
- 1 h...10 h
- 10 h...100 h

■ 14 ranges:

- 1.2 s
- 3 s
- 12 s
- 30 s
- 120 s
- 300 s
- 12 min
- 30 min
- 120 min
- 300 min
- 12 h
- 30 h
- 120 h
- 300 h

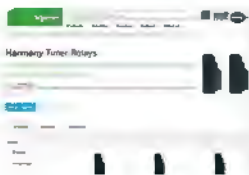

Learn more about
Harmony
Timer Relays
range here



Offer



Catalogue

Scan or
click on
QR code

If you need more details about product references and availability, please check your local Schneider Electric contact <https://www.se.com/ww/en/work/support/country-selector/contact-us.jsp>

Harmony Electromechanical relays

Interface, miniature, and power electromechanical relays



Harmony relays offer interface, miniature, universal, and power electromechanical relays, from 1 CO to 4 CO contacts, up to 30 A. The electromechanical relays help to reduce the size of enclosures and at the same time increase machine reliability.

Harmony Electromechanical relays

- Used to multiply the number of input and output contacts, or for logic processing control

RSL relays for compactness

Flexible offer

- Available as a single-referenced complete product (relay and socket) or customer-assembled product
- Wide choice of sockets ranging from 12 to 230 V ~
- Standard and low level contact types.

Enhanced performance

- Sockets with integrated reverse polarity protection circuit
- Relays for high breaking capacity or low-level current application requirements
- Power-on and Relay status LED indicator.

Simple installation and cabling

- Locking/unlocking lever for removing and replacing the relay in the socket
- Simple DIN rail mounting and commoning link accessory
- Choice of screw connector or spring terminal connection for sockets.

RSL relays are compact modular relays conforming to IEC/EN 61810-1, UL508, CSA C22.2 No. 14, and EAC international standards.



LED indicator for RSL relay status



Screw connector



Spring terminal



Learn more about Harmony Electromechanical Relays range here



Offer



Catalogue

Scan or click on QR code

If you need more details about product references and availability, please check your local Schneider Electric contact <https://www.se.com/ww/en/work/support/country-selector/contact-us.jsp>

Harmony Electromechanical relays

RXG relays for reliability

Complete offer

RXG relays offer a broad range of coil voltages, from 6 V to 110 V $\overline{\text{---}}$ and 24 V to 230 V \sim . The relays are available with/without lockable test button, LED, and clear cover.

Easy to mount and use

These are the latest relays with a single-step lockable test button. The Faston pin terminal mounts quickly and securely. The slim 16 mm/0.629 in. socket for 2 CO saves panel space.

Expandable relays

RXG relays can be expanded with protection modules such as diode, diode with LED, varistor with LED, and RC circuit.



> Latest interface relay with easy testing function



Single-step lockable test button

RXM relays for automation control

Easy to select

- Wider choice of contacts (2, 3, and 4 CO)
- Broad range of control circuit voltages and different socket types.

Convenient to use

- One-step lockable test button
- Mechanical indicator for contact status
- "Power On" LED for readiness.

Simple to install

- 64% less wiring time with Push-in Sockets (no screwdriver required)
- Sockets for both DIN rail and panel mounting, time-saving bus jumper
- Direct mounting with DIN rail or flange adapter.

Designed to perform

- Eco-design with RoHS and REACH
- Flexible add-on protection modules
- Push-in Socket with 223.75 Newton max pull out force, reliable in vibration environment.

RXM industrial relays bring features for easy and improved control of simple and complex automation systems.



> Miniature in size and powerful in performance



LED indicator for relay status

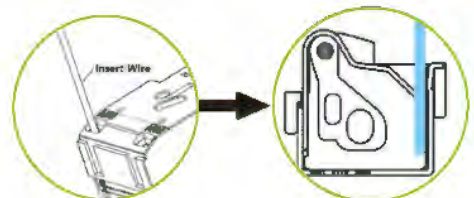

Push-in terminal: insert without tool

Note: The Zelio Relays range name has been changed in 2020 to Harmony Relays. As the timeline for each range is different, during the transition period there will be both Zelio and Harmony ranges shown on different product datasheets and packaging.



Harmony Electromechanical relays

A
B
C
D
E
F
G
H
I
J

Type		Plug-in relays													
															
		RXG●●●● [1]													
		Interface relays													
Number and type of contacts/conventional thermal current (Ith on NO contact)															
		<ul style="list-style-type: none"> ■ 1 CO/10 A ■ 2 CO/5 A 													
Control circuit voltage															
~		24...230 V													
=		6...110 V													
Pin type															
		Flat (Faston type)													
Operational voltage															
		Up to 250 V ~													
Durability (operating cycles per hour)															
Electrical, resistive load		100,000													
Mechanical, no-load		<ul style="list-style-type: none"> ■ 10,000,000 for AC coil ■ 10,000,000 for DC coil 													
Functions															
LED		Yes (depending on version)													
Mechanical indicator		Yes (depending on version)													
Test button		Yes, lockable (depending on version)													
Contact type		Standard													
Accessories															
Mounting adapters for DIN rail		No													
Mounting adapters with fixing lugs		No													
Type of associated		Sockets													
															
		RGZE1S35M		RGZE1S48M		RGZE05P		RGZE08P		RGZE05E		RGZE08E			
Contact terminal arrangements															
						Separate						Mixed			
Connection															
				Screw connector				Push-in terminals				Screw clamp terminals			
Accessories															
Protection modules		Yes						No							
Timer module		No													
Maintaining clamps		Yes (plastic, integrated)													
Socket identification legend		Yes						No							
Bus jumper		Yes						Yes, 2-pole				No			
Conventional thermal current (Ith)															
		10 A for 1 CO		5 A for 2 CO		10 A		5 A		10 A		5 A			

[1] Pre-assembled interface relays RSL1PV●● and RSL1PR●● (standard type relay + socket), RSB (relay + socket + clamp + protection module + label), and RXG (relay + socket + protection module) are also available.

[2] When using relay RSB1A160●● with socket RSZE1S48M, terminals must be linked.

Harmony Electromechanical relays



RSL1●B4●D^[1]

Slim interface relays

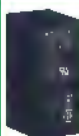

RSB●●●●●●●●^[1]

Interface relays

1 CO/6A

- 1 CO/16 A
- 1 CO/12 A
- 2 CO/8 A

–
12...60 V

24...240 V
6...110 V

Flat (PCB type, reinforced)

Flat (PCB type)

Up to 400 V ~/300 V ~

60,000
10,000,000

100,000
30,000,000

No
No
No
Standard and low level

Yes (with protection modules)

Standard

Sockets with LED and protection circuit

Sockets without LED



RSLZV●●



RSLZR●●



RSZE1S35M



RSZE1S48M



RSZE05P



RSZE08P

Separate

Screw connector

Spring terminals

Screw connector

Push-in terminals

No
No
No
Yes
Yes, 20-pole

No
No
No
Yes

Yes
No
Yes
Yes
Yes

Yes
No
Yes (plastic, integrated)
Yes
Yes, 2-pole

6A

6A

12A

(2 terminals) x 10 A^[1]

12A

10A



Harmony Electromechanical relays

A
B
C
D
E
F
G
H
I
J

Type		Plug-in relays	
			
		RXM●●●●●● [1] Miniature relays	
Number and type of contacts/conventional thermal current (Ith on NO contact)			
		<ul style="list-style-type: none"> ■ 2 CO/12 A ■ 3 CO/10 A ■ 4 CO/6 A ■ 4 CO/3 A (low level) 	
Control circuit voltage			
~	24...240 V		
≡	12...220 V		
Pin type			
		Flat (Faston type)	
Operational voltage			
		Up to 250 V ~	
Durability (operating cycles per hour)			
Electrical, resistive load	100,000		
Mechanical, no-load	10,000,000		
Functions			
LED	Yes (depending on version)		
Mechanical indicator	Yes		
Test button	Yes, lockable		
Contact type	Standard and low level		
Accessories			
Mounting adapters for DIN rail	Yes		
Mounting adapters with fixing lugs	Yes		
Type of associated		Sockets without LED	
			
		RXZE2M114M	RXZE2M114
		RXZE2S●●●M	RXZE14P
Contact terminal arrangements			
		Mixed	Separate
Connection			
		Screw connector	Screw clamp terminals
		Screw connector	Push-in terminals
Accessories			
Protection modules	Yes		Yes
Timer module	No		No
Maintaining clamps	Yes		Yes (plastic, integrated)
Socket identification legend	Yes		Yes
Bus jumper	No		Yes, 2-pole
Conventional thermal current (Ith)			
		10 A	10 A
		<ul style="list-style-type: none"> ■ 12 A for 2 CO [2] ■ 6 A for 4 CO 	<ul style="list-style-type: none"> ■ 12 A for 2 CO ■ 6 A for 4 CO

[1] Pre-assembled miniature relays RXM (relay + socket + clamp + label) are also available.

[2] Except for sockets RXZE2S11●M: 10 A.

[3] To be used with specified sockets only.

Harmony Electromechanical relays



782X●XH●●●●^[3]

Hermetically sealed relays

- 4 CO/5 A
- 4 CO/3 A (low level)
- 2 CO/5 A

6...240 V
6...110 V

Flat (Plug-in type)^[3]

Up to 264 V ~/121 V ---

100,000
10,000,000

No
No
No
Standard and low level

No
No

Sockets

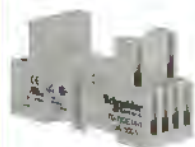

70-782E14-1



70-461-1

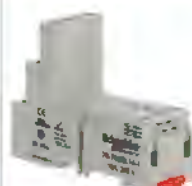

70-782EL14-1



70-378-1



70-379-1

Mixed

Separate

–

–

Screw connector

Screw clamp terminals

Screw connector

Solder lug

PCB pins

Yes
No
Yes
Yes
–

No
No
Yes
No
–

Yes
No
Yes
Yes
Yes, 2-pole

No
No
Yes
–
–

No
No
Yes
–
–

10 A

10 A

10 A

5 A

10 A

A

B

C

D

E

F

G

H

I

J

Harmony Electromechanical relays

Type	Plug-in socket mount	Panel/DIN rail mount with flat (Faston type) terminals	Panel/DIN rail mount with screw terminals
	 <p>725●XX●BM4L-● Power relays</p>	 <p>725●XX●BC3ML-●</p>	 <p>725●XX●SC3ML-●</p>
<p>Number and type of contacts/conventional thermal current (Ith on NO contact)</p> <ul style="list-style-type: none"> ■ 1 NO/30 A ■ 2 NO/25 A 			
<p>Control circuit voltage</p> <p>~ 24...240 V --- 12...24 V</p>			
<p>Pin type</p> <p>Flat (Faston type) Screw type</p>			
<p>Operational voltage</p> <p>Up to 264 V ~/26.4 V ---</p>			
<p>Durability (operating cycles per hour)</p> <p>Electrical, resistive load 100,000 Mechanical, no-load 5,000,000</p>			
<p>Functions</p> <p>LED Yes Mechanical indicator Yes No Test button Yes, lockable Yes, non-lockable Contact type Standard</p>			
<p>Accessories</p> <p>Mounting adapters for DIN rail No - - Mounting adapters with fixing lugs No - -</p>			
<p>Type of associated Sockets</p>  <p>70-725-1</p>			
<p>Contact terminal arrangements</p> <p>Separate -</p>			
<p>Connection</p> <p>Screw connector -</p>			
<p>Accessories</p> <p>Protection modules Yes - - Timer module No - - Maintaining clamps Yes - - Socket identification legend - - - Bus jumper No - -</p>			
<p>Conventional thermal current (Ith)</p> <p>30 A -</p>			

[1] 100,000 for RPM1 and RPM2; 60,000 for RPM3 and RPM4.

[2] 30 A when mounted with 13 mm (0.51 in.) gap between two relays and 25 A when mounted side-by-side without a gap.

Harmony Electromechanical relays

Plug-in relays			Relays with clamp fixing		
 <p>RPM●●●● Power relays</p>			 <p>RUM●●●● Universal relays</p>		 <p>RPF●●●● Power relays</p>
<ul style="list-style-type: none"> ■ 1 CO/15 A ■ 2 CO/15 A ■ 3 CO/15 A ■ 4 CO/15 A 	<ul style="list-style-type: none"> ■ 2 CO/10 A ■ 3 CO/10 A 	<ul style="list-style-type: none"> ■ 2 CO/10 A ■ 3 CO/10 A 	<ul style="list-style-type: none"> ■ 2 NO/30 A^[2] ■ 2 CO/30 A^[2] 		
12...110 V	24...230 V 12...220 V		12...110 V	12...24 V	
Flat (Faston type)	Cylindrical		Flat (Faston type)	Flat (Faston type)	
Up to 250 V \sim	Up to 250 V \sim		Up to 250 V \sim	Up to 250 V \sim	
100,000 ^[1] 10,000,000	100,000 5,000,000		100,000 5,000,000		
Yes (depending on version) Yes Yes, lockable Standard	Yes (depending on version) Yes Yes, lockable Low level (depending on version)		Standard	-	
Yes Yes	No No			-	
Sockets without LED					
 <p>RPZF●</p>			 <p>RUZC●M</p>	 <p>RUZSC●M</p>	 <p>RUZSF3M</p>
Mixed	Mixed	Separate			
Screw connector	Screw connector				
Yes Yes (for 3-pole and 4-pole) Yes (on socket RPZF1) Yes No	Yes Yes Yes Yes No		Yes, 2-pole (I _{th} = 5 A)	-	
16 A	12 A				

Note: The Zelio Relays range name has been changed in 2020 to Harmony Relays. As the timeline for each range is different, during the transition period there will be both Zelio and Harmony ranges shown on different product datasheets and packaging.



Harmony Solid State relays

Slim interfaces, Modular DIN rail and Panel mount solid state relays

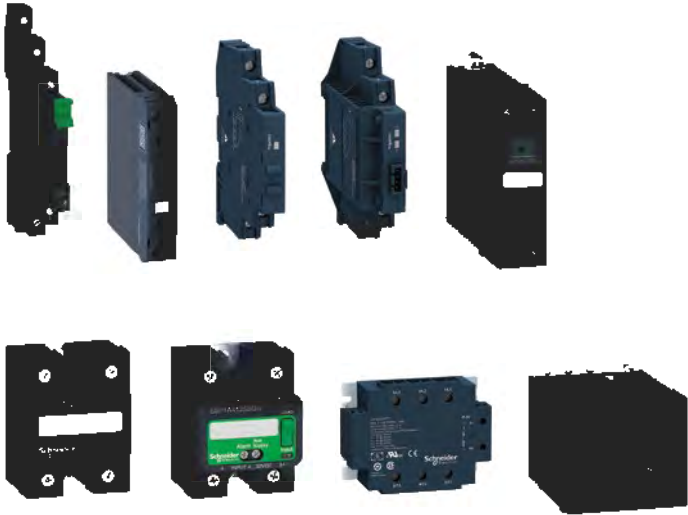

The Harmony SSR series offers slim interface (SSL), modular DIN rail (SSD, SSM) and panel mount (SSP) solid state relays that provide complete, compact, and innovative solutions for a wide variety of applications with interfacing control and load switching.

They are the ideal solution for packaging, plastic molding, textile, and heating furnace applications.

Harmony Relays - Solid State relays

- Choose long life and silent operation with Harmony SSRs

Maintenance free

fully electronic, unlimited life span

Silent and reliable switching

no moving parts, noiseless switching

High switching frequency

allows precise and quick control

Sustainability in harsh environment

resistance to shock, vibration, and contamination

Harmony Solid State relays

SSL solid state slim interface relays

Choose a slim interfacing solution with SSL relays

Slim relay-socket solution

- Complete range of control input and load output configurations for both AC and DC switching applications
- Compact solution with 6 mm/0.236 in. width, allows customers to choose the combination of relays and associated sockets from the wide range available.

Pre-assembled SSL relays ^[*]	
Control input voltage	Load output voltage
<ul style="list-style-type: none"> ☐ 4...12 V ☐ 16...30 V 	<ul style="list-style-type: none"> ■ 1...24 V ■ 1...48 V ■ ~ 24...250 V ■ 1...24 V ■ 1...48 V ■ ~ 24...250 V

[*] SSL relays + SSLZ sockets.



SSL slim interface relay mounted on SSLZ socket

Enhanced performance in any situation

- Socket with integrated reverse polarity protection circuit and control input/relay status LED indicator
- IP67 protection and fully encapsulated.



LED indicator for relay status

Simplified installation and mounting

- Locking/unlocking lever for replacing relay from the socket
- Simple mounting on DIN rail
- Choice of screw connector and spring terminal connection for sockets.



Screw connector



Spring terminal



> SSL (1-phase) + SSLZ (socket) = Slim plug-in interface solution



General overview

Harmony Solid State relays

SSD solid state DIN rail mount relays

Choose reliability and flexibility with innovative DIN rail mount SSD relays

Performance

- High I²T (up to 8320 A²S) to facilitate the use of circuit breakers instead of fuses, allowing Type 1 coordination protection (as per IEC 60947-4-3)
- High current rating (up to 35 A for 22.5 mm models, and up to 60 A for 45 mm models) at a compact size, optimizing the size of your enclosure
- Surge protection from applications with built-in transient overvoltage protection.

Flexibility

- Relay and Contactor configuration to suit your wiring preferences
- Telescopic screw terminal options available to facilitate the use of lug terminals.

Simplified selection and installation

- Integrated heat sink to eliminate the need for thermal calculation
- Spring and screw input connectors option is available for simplified wiring.

Wide range of standards and certifications

- Complies with IEC 61373 for railway and rolling stock application
- Electromagnetic compatibility complying to IEC 60947-4-3 standard
- Conforms to a wide range of internationally recognized standards and certification.

SSD relays

Control input voltage	Load output voltage
⎓ 4...32 V	■ ⎓ 1...150 V
⎓ 90...280 V	■ ~ 48...600 V
	■ ~ 48...600 V



Relay configuration



Pluggable Spring input connectors

Pluggable Screw input connectors

22.5mm/0.886 in.



SSD1: 20, 30 and 35 A single-phase SSR

45mm/1.772 in.



SSD1: 45 and 60 A single-phase SSR

Note: The SSD1 range references will be substituting the SSM1 range references for 22.5 mm/0.886 in. width (20 A, 30 A) and 45 mm/1.771 in. width (45 A, 55 A).



> The new generation solid state relays

Harmony Solid State relays

SSM solid state modular DIN rail mount relays

Choose modularity with DIN rail mount SSM relays

Ready to use "Plug and play"

- Modular design of IP20 housing and built-in heat sink for optimized operating conditions
- Easy mounting on standard 35 mm/1.378 in. DIN rail with a secure mounting latch.

Compact design

- Requires less panel space due to slim width and thus reduces the size of your enclosures
- Optimized modular design available in various sizes (11, 18, 22.5, 45 and 90 mm width) with load output current of 6, 12, 20, 30, 45, and 55 A.

SSM1 relays		SSM2 relays	
Control input voltage	Load output voltage	Control input voltage	Load output voltage
DC 4...32 V	<ul style="list-style-type: none"> DC 1...48 V DC 24...100 V 	DC 4...32 V	<ul style="list-style-type: none"> AC ~ 24...280 V AC ~ 48...600 V
AC 4...32 V	<ul style="list-style-type: none"> AC ~ 24...280 V AC ~ 48...600 V 	-	-
<ul style="list-style-type: none"> AC ~ 18...36 V AC ~ 90...140 V AC ~ 200...265 V 	<ul style="list-style-type: none"> AC ~ 24...280 V AC ~ 48...600 V 	-	-

SSM1 relays	
Control input voltage	Load output voltage
DC 4...32 V	<ul style="list-style-type: none"> AC ~ 24...280 V AC ~ 48...660 V
DC 3...32 V	AC ~ 24...280 V
<ul style="list-style-type: none"> AC ~ 90...140 V AC ~ 90...280 V 	<ul style="list-style-type: none"> AC ~ 24...280 V AC ~ 48...660 V

SSM3 relays	
Control input voltage	Load output voltage
DC 4...32 V	AC ~ 48...600 V
AC ~ 90...140 V	AC ~ 48...600 V
AC ~ 180...280 V	AC ~ 48...600 V

Enhanced modular solution

- Wide choice of relays with single-phase and three-phase options and current ratings from 6 A to 55 A
- Zero voltage switching for resistive loads and random switching for inductive loads
- UL and cUL approved including the general purpose and motor controller rating standards.

+ **> SSM1 (1-phase) / SSM2 (1-phase dual channel) / SSM3 (3-phase)**
= Plug & Play solution

11 mm/0.433 in.



SSM1: 6 A single-phase SSR

18 mm/0.709 in.



SSM2: 6 A dual channel, single-phase SSR

22.5 mm/0.886 in.



SSM1: 20 and 30 A single-phase SSR

45 mm/1.772 in.



SSM1: 45 and 55 A single-phase SSR

90 mm/3.543 in.



SSM3: 25 A three-phase SSR



General overview

Harmony Solid State relays

SSP solid state panel mount relays

Choose a complete panel mount solution with SSP relays

Complete solution

- Single-phase and three-phase panel mount solid state relays with a range of heat sinks and accessories to meet application needs from 10 A to 125 A
- Easy product selection with simplified product nomenclature and direct heat sink selection available in product data sheets
- Wide choice of heat sinks with thermal resistance ratings of 0.2°C/W to 2.5°C/W.

SSP1 relays

Control input voltage	Load output voltage
≡ 3.5...32V	≡ 1...150V
≡ 3...32V	~ 24...300 V
≡ 4...32V	~ 48...660 V
~ 90...280V	■ ~ 24...300 V
	■ ~ 48...660 V

SSP1.S relays

Control input voltage	Load output voltage
≡ 3...32V	~ 24...300 V
≡ 4...32V	~ 48...660 V

SSP3 relays

Control input voltage	Load output voltage
≡ 4...32V	~ 48...530 V
■ ~ 18...36 V	~ 48...530 V
■ ~ 90...140 V	
■ ~ 180...280 V	

Simple, safe, and robust screw terminals

- Simple and easy wiring; accepts wires with different kinds of terminations (cable ends, fork lug, ring lug)
- Safe and fool-proof design with IP20 protection and integrated enclosure
- Robust self-aligned screw terminals with proven effectiveness in helping to prevent screw jams.

Innovative SSP1.S with smart diagnostics and test button

- Smart diagnostic features with built-in visual indicator and alarm output enables quick response to unexpected results and correct monitoring of SSR operation
- A test button for easy debugging, testing, and commissioning.

Simplified installation and mounting

- Product option with readily available factory-fit thermal pad
- Heat sink offers panel and DIN rail mounting options.

+ **> SSP1 (1-phase) / SSP3 (3-phase) + SSRH (Heat sinks)**
= Complete solution



SSP1: Single-phase panel mount SSR



SSP1.S: Single-phase panel mount SSR with smart diagnostic features



SSP3: Three-phase panel mount SSR

General overview

Harmony Solid State relays



Harmony Solid State relays

Type	Slim interface SSR		Modular DIN rail SSR	
				
	Customer assembly (Relay and socket)	Pre-assembly (Relay with socket)		
Solid state Relay type	SSL ^{[1][2]}		SSD1 ^[3]	SSM1
Number of phase	1			
Type of mounting	Plug-in PCB pins with DIN rail mounted socket		DIN rail mounted	
Control input voltage				
~	-	-	90...280 V	<ul style="list-style-type: none"> ■ 18...36 V ■ 90...140 V ■ 200...265 V
≡	<ul style="list-style-type: none"> ■ 3...12 V ■ 15...30 V ■ 16...30 V 	<ul style="list-style-type: none"> ■ 4...12 V ■ 16...30 V 	<ul style="list-style-type: none"> ■ 4...32 V ■ 90...280 V 	4...32 V
Output load voltage				
~	24...280 V	24...250 V	48...600 V	<ul style="list-style-type: none"> ■ 24...280 V ■ 48...600 V
≡	<ul style="list-style-type: none"> ■ 1...24 V ■ 1...48 V 	<ul style="list-style-type: none"> ■ 1...24 V ■ 1...48 V 	1...150 V	<ul style="list-style-type: none"> ■ 1...60 V ■ 1...100 V
Output load current				
~	2 A		<ul style="list-style-type: none"> ■ 20, 35 A for 22.5 mm/0.886 in. ■ 40, 60 A for 45 mm/1.772 in. 	<ul style="list-style-type: none"> ■ 6 A for 12 mm/0.472 in. ■ 12 A for 18 mm/0.709 in.
≡	0.1, 3.5 A		20, 30 A for 22.5 mm/0.886 in.	<ul style="list-style-type: none"> ■ 6 A for 12 mm/0.472 in. ■ 12 A for 18 mm/0.709 in.
Type of switching				
Zero voltage	Yes			
Random	Yes			
DC	Yes			
Cooling	-		Built-in heat sink	
Degree of protection	<ul style="list-style-type: none"> ■ IP67 (encapsulation) ■ IP20 (socket) 		IP20	
LED indication	Yes (on socket)		Yes	

[1] SSL slim relays and SSLZ sockets.

[2] Pre-assembled SSL slim relays (relay + socket).

[3] The SSD1 range references will be substituting the SSM1 range references for 22.5 mm/0.886 in. width (20 A, 30 A) and 45 mm/1.771 in. width (45 A, 55 A).

Selection guide

Harmony Solid State relays

				Panel mount SSR	
					
SSM1 [3]		SSM2	SSM3	SSP1	SSP3
1		1 (dual SSR)	3	1	3
DIN rail mounted				Panel mounted	
<ul style="list-style-type: none"> ■ 90...140 V ■ 90...280 V 		–	<ul style="list-style-type: none"> ■ 90...140 V ■ 90...280 V 	90...280 V	<ul style="list-style-type: none"> ■ 18...36 V ■ 90...140 V ■ 200...265 V
<ul style="list-style-type: none"> ■ 3...32 V ■ 4...32 V 		4...32 V	4...32 V	<ul style="list-style-type: none"> ■ 3...32 V ■ 4...32 V 	4...32 V
<ul style="list-style-type: none"> ■ 24...280 V ■ 48...660 V 		<ul style="list-style-type: none"> ■ 24...280 V ■ 48...600 V 	48...600 V	<ul style="list-style-type: none"> ■ 24...300 V ■ 48...660 V 	48...530 V
–		–	–	1...150 V	–
<ul style="list-style-type: none"> ■ 20, 30 A for 22.5 mm/0.886 in. ■ 45, 55 A for 45 mm/1.772 in. 		6 A	25 A	10, 25, 50, 75, 90, 125	25, 50 A
–		–	–	12, 25, 40 A	–
Yes		–	Yes	–	Yes
–		Yes	–	Yes	–
Built-in heat sink				Option with thermal pad	
IP20					
Yes					

- A
- B
- C
- D
- E
- F
- G
- H
- I
- J



Learn more about
Harmony
Solid State Relays
range here



Offer



Catalogue

Scan or
click on
QR code

If you need more details about product references and availability, please check your local Schneider Electric contact <https://www.se.com/ww/en/work/support/country-selector/contact-us.jsp>

Modicon Power Supply



A

B

C

D

E

F

Regulated power supply for industrial use, rail mounting

The **Modicon** switch mode power supply offer is designed to provide the DC voltage necessary for the automation system equipment control circuits.

They are fully electronic with a regulated output voltage. The use of electronics makes it possible to significantly improve the performance of these power supplies, which offer

- Compact dimensions
- Integrated overload, short-circuit, overvoltage, and undervoltage protection
- Wide input voltage range
- High degree of output voltage stability
- Efficiency
- Diagnostics via LEDs on the front panel
- Remote diagnostics via relay contact with ABL8RP/WP Universal.

They deliver a stabilized DC output voltage that is precise to less than 3%, whatever the load from an AC line supply, within the following ranges:

- 100 to 240 V AC for phase-to-neutral (N-L1) or phase-to-phase (L1 – L2) connections for the ABLM Modular, ABLS Optimized and ABL8RPM universal types
- 100 to 500 V AC for phase-to-neutral (N-L1) or phase-to-phase (L1 – L2) connections for the ABL8RPS Universal types
- 380 to 500 V AC for 3-phase connections (L1-L2-L3) for the ABL8WP Universal types
- They comply with IEC standards and are certified to comply with the major certifications bureau standards. Power supplies with 24 V DC output and power output equal or lower than 90 W are also NEC Class 2 and Limited Power Source compliant
- The harmonic pollution is reduced to a minimum level across the entire Modicon power supply types, ensuring compliance with the requirements of standard IEC/EN 61000-3-2.

Modicon power supplies incorporate

- An output voltage adjustment potentiometer to help compensate for any line voltage drops in installations with long cable runs
- Direct mounting on 35 mm (1.37 in) omega rail.

G

H

I

J

Modicon ABLM Modular power supply



Modicon ABLM Modular power supply

Description

The ABLM Modular type meets the needs of simple automation systems with power ratings from 10 to 60 W and an output voltage of 5, 12 or 24 V DC.

- The shape and compact nature of the housing mean that it can be mounted directly on a panel, in a modular distribution panel or on a omega rail in a cabinet
- **Modicon** ABLM Modular power supply conform to the Overvoltage Category III and therefore can be directly connected to central distribution boards. In the event of an overload the power supply protection interrupts power; when the source of the overload has been corrected, the power supply reverts to its nominal state (automatic reset).

Modicon ABLS Optimized power supply



Modicon ABLS Optimized power supply

Description

The ABLS Optimized type offers competitive functionality for applications supplied with 12, 24 or 48 V DC and with power ratings from 50 W up to 480 W.

Modicon ABL8RP/WP Universal power supply



Modicon ABL8RP/WP Universal power supply

Description

The ABL8RP/WP Universal type covers power ratings from 72 to 960 W in 24 V DC and adapts to the majority of power distribution networks used throughout the world. The same power supply can thus be connected phase-to-neutral (N-L1) or phase-to-phase (2 or 3 phases) for line supplies ranging from 100 V AC to 500 V AC nominal.

The ABL8RP/WP Universal type offers:

- Diagnostic functions (local or remote)
- User choice of operating mode in the event of an overload (automatic or manual reset)
- Functional modules to help continuity of service, for protection against microbreaks or prolonged outages, for paralleling and redundancy functions and for discriminating protection against application overloads
- A power reserve (boost function) for absorbing the transient current peaks required by the application.

With ABL8RP/WP Universal power supplies, it is possible to meet the need for auxiliary voltage (5 to 15 V DC) using DC/DC converter modules.

Modicon Power Supply

A

Protective extra low voltage (PELV) and Safety extra low voltage (SELV)

- The Modicon power supplies can be used to supply protection extra low voltage (PELV) or safety extra low voltage (SELV) control circuits in compliance with standard IEC/EN 60364-4-41
- They have the following characteristics:
 - Double insulated between the input circuit (connected to the line supply) and the low voltage output circuit via an integrated isolation transformer
 - Internal circuitry limiting the output voltage to less than 60 V under single fault conditions.



B

C

Harmonic pollution (power factor)

- The current drawn by a power supply is not sinusoidal. This leads to the generation of harmonic currents that pollute the distribution network
- European standard IEC/EN 61000-3-2 limits the harmonic currents produced by power supplies
- This standard covers devices between 75 and 1000 W, drawing up to 16 A per phase, and connected directly to the public distribution network
- **Modicon** ABLU3, ABL8RP/WP Universal and ABLS Optimized from 75 W power supplies conform to IEC/EN 61000-3-2 and can therefore be connected directly to public distribution networks
- Since ABLM Modular, ABLS1A12062, ABLS1A24021, and ABLS1A24031 power supplies have power ratings that are less than 75 W, they are not subject to the requirements of standard IEC/EN 61000-3-2. They can therefore be connected directly to public distribution networks.



D

E

F

G

H

I

J

Output characteristics & conditions of use

- The ambient temperature is a determining factor that limits the power an electronic power supply can deliver continuously
- If the temperature around the electronic components is too high, the integrated overtemperature protection could activate and/or the lifetime of the power supply may be significantly reduced
- Depending on product type, the upper nominal ambient temperature is 50 or 55°C (122 or 131°F) for a standard mounting position, at 230 V AC input voltage. Above this temperature with different input voltages, and/or with other mounting positions, derating is necessary up to a maximum temperature of 60 or 70°C (140 or 158°F)
- In most cases, there must be adequate convection and sufficient clearance around the products to assist cooling
- Derating is also necessary in case of altitudes greater than 2000 m (6561.6 ft)
- The derating curves are given in each product data sheet, available on our website and directly accessible via the QR code printed in front of the product (except on ABL8 products)
- It is considered good practice to select a power supply with a nominal output current at least 20% greater than required



A

B

C

D

E

F

G

H

I

J

A



100...240 V AC

Modicon ABLM Modular power supply

Zelio Logic Smart relay

B

C

D

E

F

G

H

I

J

ABLM Modular power supply

Functions

The Modicon ABLM Modular are regulated power supplies designed to supply control circuits in industrial and building automation up to 60 W.

- Thanks to their modular housing, they can be installed either in enclosures ([PanelSeT](#)) or industrial panels by clipping on omega (DIN) rail
- Direct, fixed mounting on panel is also possible without additional parts thanks to the integrated mounting lugs
- Available with 18, 36 and 53 mm (0.70, 1.41, and 2.09 in) widths, ABLM modular power supplies are one of the most compact ranges on the market
- Modicon ABLM Modular power supply meet NEC Class 2 and LPS (Limited Power Source) requirements
- Modicon ABLM Modular power supply conform to the Overvoltage Category III and therefore can be directly connected to central distribution boards
- A QR code is printed on the front of the power supplies and gives a direct access to the latest technical documentation
- Modicon ABLM Modular power supply are the right choice for use with Zelio logic Smart relays.

Main features

Nominal input voltage	100...240 V AC
Network system compatibility	TN, TT, IT
Nominal output voltage	5, 12 and 24 V DC
Operating temperature	-25°...+70° C (-13...158° F)
Operating altitudes	<ul style="list-style-type: none"> ■ 0...2000 m (6561.6 ft) ■ 0...5000 m (16404.2 ft) with Derating

ABLS Optimized power supply

Functions

The Modicon ABLS Optimized are regulated power supplies, designed to supply control circuits in industrial applications from 50 up to 480 W.

- They are available in 2 housing formats for a better adaptation to the enclosure:
 - compact housing 75 mm height (2.95 in)
 - or book housing 124 mm height (4.88 in)
 - Available with a width from 27 mm (1.06 in), ABLS optimized power supplies are one of the slimmer ranges on the market
 - The printed circuit board of the power supplies (book housing) has a conformal coating in order to resist to common dust and chemical pollutants
 - Modicon ABLS Optimized power supply meet NEC Class 2 and LPS (Limited Power Source) requirements
 - Up to 6 output terminals make wiring easier
 - A QR code is printed on the front of power supply and gives a direct access to the latest technical documentation.
- Modicon ABLS Optimized power supply are the right choice for use with Modicon M221/M241/M251 logic controllers and Modicon M262 logic/motion controllers.

Main features

Nominal input voltage	<ul style="list-style-type: none"> ■ 100...240 V AC ■ 140...340 V DC
Network system compatibility	TN, TT, IT
Nominal output voltage	12, 24 and 48 V DC
Operating temperature	-20°...+70° C (-4...158° F)

Technical characteristics

Modicon Power Supply

- A
- B
- C
- D
- E
- F**
- G
- H
- I
- J

Modicon Power Supply

Regulated power supply for industrial use, rail mounting



Voltage

Input Voltage	100...240 V AC								100...240 V AC, 140...340 V DC ^[1]	
Nominal output power	10 W	12 W	15 W	18 W	25 W	30 W	50 W	60 W	50 W	75 W

Connection to world-wide line supplies

United States: 120 V (in phase-to-neutral) / 240 V (in phase-to-phase)	Single-phase (N-L1) or 2-phase (L1-L2) connection	Single-phase (N-L1) or 2-phase (L1-L2) connection
Europe: 230 V (in phase-to-neutral) / 400 V (in phase-to-phase)	Single-phase (N-L1) connection	Single-phase (N-L1) connection
United States: 277 V (in phase-to-neutral) / 480 V (in phase-to-phase)	-	-

Characteristics

Protection against overloads and short-circuits	Yes, with automatic restart after the source of overload/short-circuit has been corrected	Yes, with automatic restart after the source of overload/short-circuit has been corrected
Diagnostic relay	-	-
Certifications	CE marking CB Scheme cULus Listed cURus Recognized RCM EAC	CE marking CB Scheme cULus Listed cURus Recognized RCM EAC

Power supply type

Output voltage	5 V	-	-	-	ABLM1A05036	-	-	-	-	-	-
	12 V	-	ABLM1A12010	-	-	ABLM1A12021	-	ABLM1A12042	-	-	ABLS1A12062
	24 V	ABLM1A24004	-	ABLM1A24006	-	-	ABLM1A24012	-	ABLM1A24025	ABLS1A24021	ABLS1A24031
	48 V	-	-	-	-	-	-	-	-	-	-
Output rating	NEC Class 2, Limited Power Source									NEC Class 2, Limited Power Source (except ABLS1A12062)	
Compatible functional modules	-									Easy UPS control module DC-DC	

[1] Except ABLS1A24021 and ABLS1A24038.



Modicon ABL8RP/WP Universal power supply



				100...120 V AC and 200...500 V AC	100...120 V AC, 200...240 V AC	380...500 V AC			
91.2 W	120 W	240 W	480 W	75 W	120 W	240 W	480 W	480 W	960 W

	Single-phase (N-L1) or 2-phase (L1-L2) connection	-
	Single-phase (N-L1) or 2-phase (L1-L2) connection	3-phase (L1-L2-L3) connection
	Single-phase (N-L1) or 2-phase (L1-L2) connection	3-phase (L1-L2-L3) connection

	Yes with 2 possible modes: - automatic restart after the source of overload/short-circuit has been corrected - manual restart, the input voltage must be interrupted after the source of overload/short-circuit has been corrected
	Yes, depending on model
	CE marking CB Scheme cULus Listed CSA RCM EAC

-	-	-	-	-	-	-	-	-	-
-	ABLS1A12100	-	-	-	-	-	-	-	-
ABLS1A24038	ABLS1A24050	ABLS1A24100	ABLS1A24200	ABL8RPS24030	ABL8RPS24050	ABL8RPS24100	ABL8RPM24200	ABL8WPS24200	ABL8WPS24400
-	ABLS1A48025	-	-	-	-	-	-	-	-
-	-	-	-	-	-	-	-	-	-

Converter module
Redundancy module
Buffer module
Universal Battery control module
Protection module
Easy UPS control module DC-DC



Learn more about
Modicon
Power Supply
range here



Offer



Catalogue

Scan or
click on
QR code

If you need more details about product references and availability, please check your local Schneider Electric contact
<https://www.se.com/ww/en/work/support/country-selector/contact-us.jsp>

Linergy TR - Terminal blocks

- A
- B
- C
- D
- E
- F**
- G
- H
- I
- J



Terminal block and bars, earth and neutral bars as well as auxiliary connections.

Linergy terminal blocks and bars are designed to provide the quick and reliable connection performances you expect from a top-quality installation.

All Linergy terminal blocks and bars are engineered to ensure a long service life providing heat-resistant material, firm connections and high vibration-resistance.

Linergy TR terminal blocks offer a wide variety of solutions for your application:

- Multiple connection options: screw, spring, push-in technologies
- Conforms to the International standards of the IEC-UL-CCC-Marine
- RoHS compliance
- Extensive connection and test accessories - Installations are completed quickly and easily
- Marking accessories
- Plug-in bridges for all technologies.

- +**
- > Simplicity of use
- > Consistency and cross-functionality guaranteed
- > Few references for a maximum of applications

Technical characteristics

Linergy TR - Terminal blocks

Low Voltage control and signalling

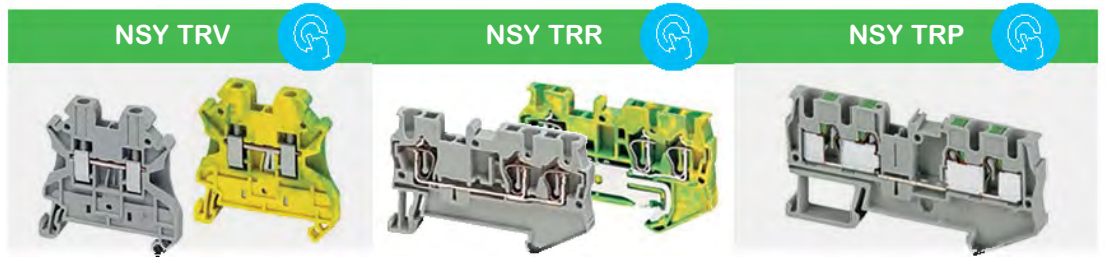

	NSY TRV	NSY TRR	NSY TRP
Function	Ensures connection of Low Voltage cables or wires	Ensures connection of Low Voltage cables or wires	Ensures connection of Low Voltage cables or wires
Technology	Screw clamp technology	Spring clamp technology	Push-in technology
Connection functions	<ul style="list-style-type: none"> • Passthrough (2.5 - 150 mm²) • Protective earth • Disconnect type (blade or fuse) • Double deck, multi-pole • Multifunction • Neutral disconnect 	<ul style="list-style-type: none"> • Passthrough (2.5 - 35 mm²) • Protective earth • Disconnect type (blade or fuse) • Double deck, multi-pole 	<ul style="list-style-type: none"> • Passthrough (2.5 - 4 mm²) • Protective earth • Disconnect type (blade or fuse) • Double deck, multi-pole
Conductor nominal c.s.a. (cross section area)	2.5 mm ² to 150 mm ²	2.5 mm ² to 35 mm ²	2.5 mm ² and 4 mm ²
Number of poles	<ul style="list-style-type: none"> • 1 - 1 x 1 / 1 - 2 x 2 • 2 - 1 x 1 / 3 - 1 x 1 	<ul style="list-style-type: none"> • 1 - 1 x 1 / 1 - 1 x 2 / 1 - 2 x 2 • 2 - 1 x 1 / 2 - 1 x 2 / 3 - 1 x 1 	<ul style="list-style-type: none"> • 1 - 1 x 1 / 1 - 1 x 2 / 1 - 2 x 2 • 2 - 1 x 1 / 2 - 1 x 2 / 3 - 1 x 1
Clip-on mounting on rail type			
Certifications	<ul style="list-style-type: none"> • UL • CSA • VDE • ATEX • LR • GL • DNV • EAC 	<ul style="list-style-type: none"> • UL • CSA • VDE • ATEX • LR • GL • DNV • EAC 	<ul style="list-style-type: none"> • UL • CSA • VDE • ATEX • LR • GL • DNV • EAC

Benefits		
Rugged and reliable	Cost effective (quick and reliable)	Quick and innovative
This technology not only provides quality, safety and availability of equipment but optimizes installation setup and operation with their simple integrated functions	Spring technology is a maintenance-free connection method assuring separation of mechanical and electrical functions. It also eliminates the need for regular re-tightening	<ul style="list-style-type: none"> • Solid conductors or conductors with cable-ends can be directly inserted into the terminal block without tools • The actuation lever can be operated with any tool for releasing conductors



Linergy TR - Terminal blocks

Low Voltage control and signalling

A

B

C

D

E

F

G

H

I

J

Cable ends

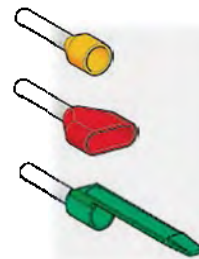

Function	<ul style="list-style-type: none"> Facilitates the insertion of wires into the terminals and assures the insulation between adjacent connection Allows the identification of the wires
Technology	Insulated cable ends
Connection functions	Four available versions: <ul style="list-style-type: none"> Single conductor cable ends Single conductor markable cable ends Uninsulated cable ends Twin conductor cable ends
Conductor nominal c.s.a. (cross section area)	0.25 mm ² to 50 mm ²
Certifications	<ul style="list-style-type: none"> UL CSA

Benefits

Fast and reliable wiring

Use the AZ5 and DZ5 ranges of cable ends to simplify wiring and provide optimum electrical continuity between wire and terminal block



Learn more about
Linergy TR -
Terminal blocks
range here



Offer



Catalogue

Scan or
click on
QR code

If you need more details about product references and availability, please check your local Schneider Electric contact <https://www.se.com/ww/en/work/support/country-selector/contact-us.jsp>

Electrical protection and control

Acti9 Active	
General overview	G-342
Acti9	
Technical characteristics	G-348
MCBs	G-348
AFDD	G-349
SPDs	G-350
iCT	G-351
iTL	G-351
Auxiliaries & Accessories	G-352
Easy9	
General overview	G-354

Acti9 Active and Acti9

- A
- B
- C
- D
- E
- F
- G
- H
- I
- J



ACTIVE

Set a new standard for electrical safety

Set a new standard for electrical safety

Active Safety System ensures enhanced safety and visibility for people, circuits, appliances, and assets. It helps prevent earth-leakage, overload, overvoltage, short-circuit, and improves fire-safety.

Acti9 Active is a family of all-in-one protection devices with in-built residual circuit devices, miniature circuit breakers, arc fault detection devices (AFDD).

Thanks to in-built connectivity, Acti9 Active can send data and notifications to the cloud via our latest generation of gateways - EcoStruxure Panel Server for remote monitoring and asset management.

Make Active Safety your new standard

Give your customers greater control over their electrical installations with an Active Safety System. Its advanced safety and connectivity features enable condition monitoring, improve visibility, power availability, and reliability, and enhance protection, service continuity, and efficiency.

The system enables you to offer more than just a safety solution. The insights it provides, along with its remote-monitoring capabilities, support business owners' efforts to ensure the continuity and quality of services and help achieve greater peace of mind.

Innovative, yet compact and functional, an Active Safety System will help you differentiate as a forward-looking professional and bring you new opportunities to develop your business.

Achieving greater resiliency and reliability through Active Safety

Enhanced protection, power availability, and reliability

Increased service continuity

- Fewer breakdowns with pre-alarms and alarms



Advanced safety

- All-in-one solutions covering a wide-range of faults, with in-built MCB, MSU, RCD, and AFDD



Enhanced efficiency

- Easy remote monitoring, diagnostics, and analytics mean fewer disruptions and more efficiency gains



Simplified installation and wireless connectivity

Simple installation and upgrade

- Integrated devices and wireless connectivity to the gateway make the system easy to install and upgrade



Compact, requiring no extra space

- An integrated device in 36 mm makes it suitable for even small spaces



Easy maintenance

- With diagnostics, analytics, and reminders for health checking, it's simple to stay on top of the panel's condition and maintain it



Acti9 Active

A

Best-in-class connectivity in a simplified form

B

To realize the full potential of visibility and advanced protection, the Active Safety System brings together a connected device, a gateway, and power monitoring software.

C

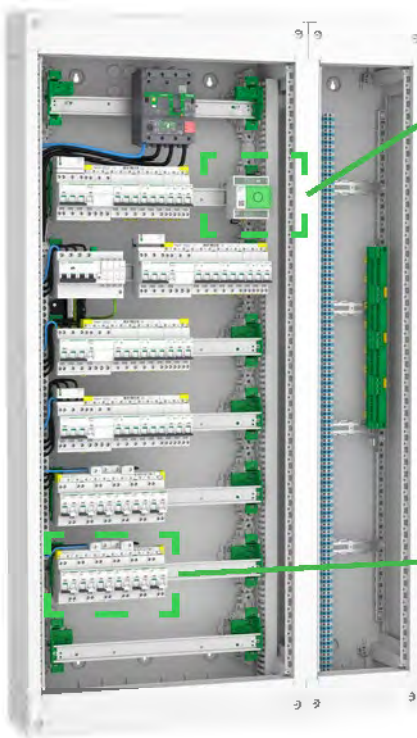

EcoStruxure Panel Server (the gateway)

One of the most advanced gateways for modern-day wireless systems. It's simple to commission and cost-efficient.

D



E



F

Acti9 Active

A range of devices providing advanced safety functions and in-built connectivity. They connect wirelessly to the gateway and send data to enable monitoring, diagnostics, pre-alarming, and alarming.

G

EcoStruxure Power Monitoring Expert

Intuitive-to-use software that aggregates installation data for greater visibility and displays actionable insights. It alerts facility managers to problems as they occur as well as to predicted issues.

H



I

J

All-in-one protection in a single 36 mm device

A core part of the Active Safety System, the Acti9 Active VigiARC with integrated residual current device (RCD), miniature circuit breaker (MCB), AFDD, and over-voltage protection delivers an exceptional level of protection for people, appliances, circuits, from fire risks – enabled by a compact all-in-one device. Available in both connected and non-connected versions, Acti9 Active supports a variety of safety and connectivity requirements.

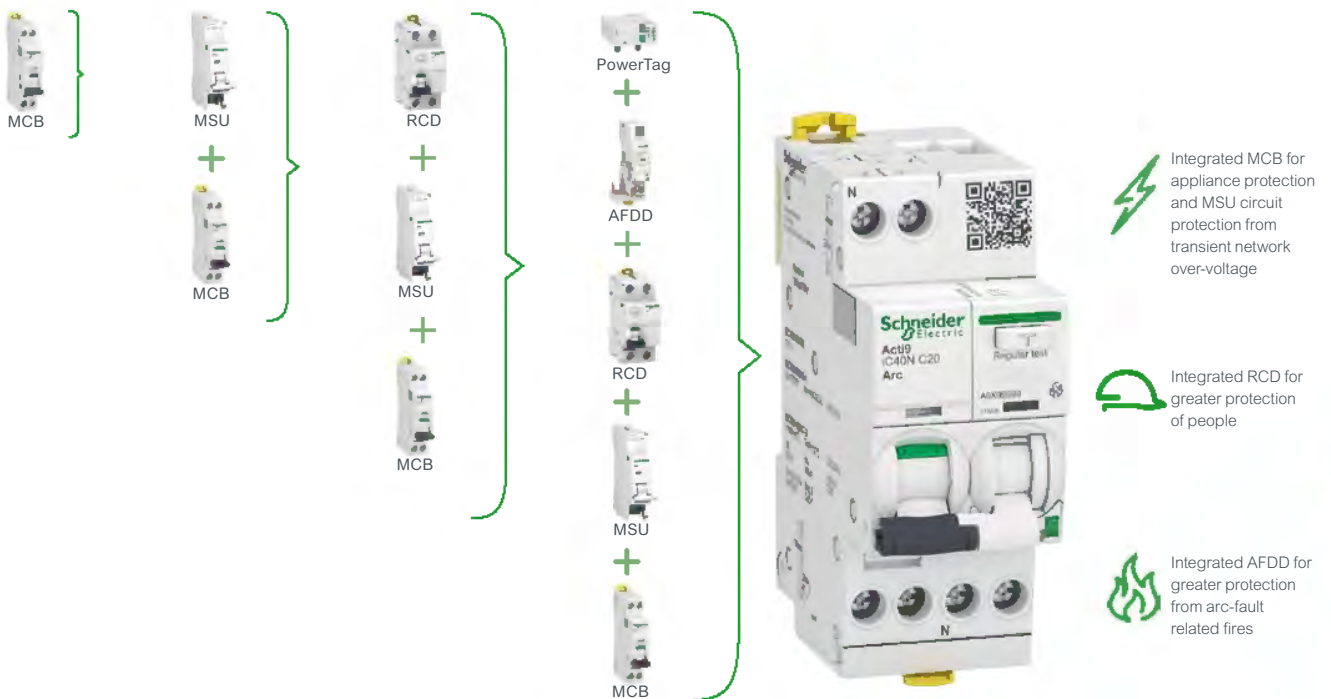

- A
- B
- C
- D
- E
- F
- G**
- H
- I
- J

Acti9 Active

Discover the full range of Acti9 Active devices

Acti9 Active devices provide advanced protection with a variety of options to suit any set-up.

Acti9 Active VigiARC



A combination of AFDD, RCD and MSU add-on

An all-in-one device with integrated connectivity and AFDD, MCB, RCD, and MSU

Acti9 Active ARC



A combination of AFDD and MSU add-on

An all-in-one device with integrated connectivity and AFDD, MCB, and MSU

Acti9 Active Vigi



A combination of RCD and MSU add-on

A

B

C

D

E

F

G

H

I

J

Acti9 Active offer specifications

	Acti9 Active VigiARC AFDD+MCB+RCD+MSU	Acti9 Active VigiARC add-on AFDD+RCD Add-on	Acti9 Active ARC AFDD+MCB	Acti9 Active ARC Add-on AFDD Add-on
Current ratings	6 A – 40 A	25 A, 40 A	10 A – 40 A	25 A, 40 A
Breaking capacity	6,000 A, 10,000 A, 10 kA	4,500 A, 6,000 A, 6 kA, 10 kA compliance	6,000 A, 10 kA	4,500 A, 6,000 A, 6 kA, 10 kA compliance
Poles	1P + N	1P + N, 2P	1P + N	1P + N, 2P
Curve	B, C	B, C	B, C	B, C
RCD sensitivity & type	30 mA, A SI	30 mA, A SI	-	-

All devices are available in two options, connected and non-connected. While advanced visibility options can be realized with the full system, the all-in-one non-connected version is also capable of advanced protection.

Whatever your needs, our Active Safety System solutions offer a range of specifications, so you can find the right connected or non-connected device for you.



Acti9

Acti9 Miniature Circuit Breakers – MCBs

A

B

C

D

E

F

G

H

I

J



Acti9 iC40

Miniature Circuit Breakers up to 40 A

- Suitable for isolation in compliance with IEC/EN 60898-1 and/or IEC/EN 60947-2
- Available in 1P+N, 3P and 3P+N for circuits up to 40 A
- Breaking capacity at 4500 A/4,5 kA, 6000 A/10 kA and 10000 A/15 kA
- Wide range of tripping curves available: B, C and D
- Class 2 insulation for optimal protection of operators and unqualified persons
- Wide range of operating temperatures: -25 / +70°C
- Sharing same key features with Acti9 iC60 in regards to aesthetics, form-factor, and range of electrical auxiliaries and accessories.
- VisiTrip offers a visible fault indicator for fast and optimized on-site servicing
- VisiSafe offers a visible green strip with reinforced insulation for maintenance in better safety conditions

Product References



Application

- Acti9 iC40 system is dedicated to the small and medium buildings applications.
- Low-voltage final distribution installations.



Acti9 iC60

Miniature Circuit Breakers up to 63 A

- Fully compliant with standards IEC/EN 60898-1 and IEC/EN 60947-2
- VisiSafe: provides protection during maintenance work on downstream circuits
- VisiTrip: signals with a redflag the faulty miniature circuit breaker outgoers to reduce intervention time
- Class-2 insulation: double insulation distance to ensure continuous protection or both operators and unqualified persons
- Pollution Class 3 for operation in more polluted environments such as some industrial applications
- Add-on fully immune Acti9 iC60 Vigi earth leakage protection devices: improved continuity of service, especially in polluted environments and networks
- Offers a wide range of electrical auxiliaries: remote indication of Acti9 iC60 status and several tripping actuators: shunt trip, undervoltage trip, overvoltage trip.

Product References



Application

- Providing essential protection in industrial and commercial buildings, our miniature circuit breakers work especially well in polluted environments and networks.



Acti9 C120

Miniature Circuit Breakers up to 125 A

- Nominal current: 63 A to 125 A
- Large choice of breaking capacities (up to 15 kA at 415 VAC) and tripping curves (B, C, D)
- Compliant with IEC/EN 60898-1 or IEC/EN 60947-2 (depending of the version)
- Suitable for isolation: compliant with IEC/EN 6047-2
- VisiSafe provides a visible green indicator showing which circuits are disconnected and safe for maintenance operations
- Operating voltage: up to 440 V AC
- Insulation voltage: 500 V AC
- IP20 terminal insulation
- Optional add-on residual current device modules: Acti9 Vigi C120
- Optional electrical auxiliaries for remote open/closed status for standard and advanced applications (OF/SD low current version compatible with PLC)
- Comb busbar 1P/2P/3P/4P up to 125 A.

Product References



Application

- Protection of electrical circuits in all industrial and commercial buildings.
- Protection of electrical circuits in medium, large and commercial buildings and Industry.



Acti9 NG125

High performance Miniature Circuit Breakers up to 125 A

- Nominal current: 10 to 125 A
- Provides the user with a large choice of breaking capacities (up to 50 kA at 415 VAC) and tripping curves: B, C, D...
- Fully Compliant with standards: IEC 60947-2
- Suitable for isolation in accordance with industrial standards: IEC/EN 60947-2
- Operating voltage: up to 500 V AC
- Insulation voltage: 690 V AC
- Provides installers with optional add-on earth leakage modules: Acti9 Vigi NG125
- Several optional auxiliaries: indication of state and tripping, shunt trip, undervoltage trip, overvoltage trip
- Comb busbar 1P/2P/3P/4P up to 125 A.

Product References



Designed with providing essential protection to industrial and tertiary buildings, and machines in mind:

- Outgoers in power switchboards
- Incoming protection in modular enclosure
- Outgoers in control panel (EV, power OEMs...).

Acti9 AFDD



All-in-one integrated protection device

Acti9 AFDD range of protection devices will help you actively manage electrical safety and service continuity of your electrical installation thanks to a wide range of electrical fault protection:

- Asset protection/ Fire safety (Arc-Fault related) thanks to an inbuilt Arc Fault Detection Device (also available as Add-On).
- People protection from Earth Leakage (with inbuilt Residual Circuit Devices).
- Appliance and circuit protection from overvoltage, overload, and short-circuit (with inbuilt miniature circuit breaker).

AFDD mitigates the risk of electrical fires caused by electrical arcs resulting from faulty or worn electrical appliances and circuits.

Product References

- Worn or aging cabling
- Pinched conductors in earthed metallic cases
- Pinched extension cables trapped by doors
- Plugs being repeatedly removed by pulling the cable rather than the plug, thus causing the insulation to fail
- Rodent damage to cable insulation
- Damage caused by cables being exposed to sunlight (UV)
- Damage caused by drilling into walls with hidden electrical cables
- Loose cable connections in wall socket outlets, power strip sockets and junction boxes
- Damage caused by heat, vibration and humidity to wall mounted cables and sockets.

Focus on Acti9 Active System

The AFDD offer is available in Acti9 Active range, with new functions integrated functions such as measurement, alarm, pre-alarm...



Application

- Buildings
- Hotels
- Hospitals.



Application

Customize the Pre-Alarms based on your preference to have ample time to work on resolving the issues.

Acti9

Acti9 Surge Protection Devices – SPDs

A



Protection of electrical and electronic equipment, telephone and computer lines against transient overvoltages of atmospheric origin and maneuvering.

Acti9 iPRD

Surge Protection Devices Type 2 or 3, from 8 kA to 65 kA

- Certified for short-circuit current withstand, I_{sc} up to 50 kA (IEC 61643-11: 2011)
- The maximum discharge current covers from 8 to 65 kA
- The maximum continuous operating voltage U_c is from 275 V AC to 460 V AC
- They are suitable for any earthing system: TT, TN-S, TN-C and IT
- Withdrawable cartridges of Acti9 iPRD Surge arresters allow quick replacement of damaged devices
- It is possible to use multipolar or unipolar products for serial assembly
- The Acti9 iPRD surge arresters "r" version have dry contacts for transferring remotely the end-of-life information
- The Acti9 iPRD F40r surge arresters version is a self-protected solution with integrated back-up Fuse to ease selection and installation

Product References

D



Acti9 iPF K

Surge Protection Devices Type 2 from 20 kA to 65 kA

- Maximum discharge current: from 20 to 65 kA
- Surge arrester/disconnector combinations is certified for short-circuit current withstand I_{sc} up to 6 kA (IEC 61643-11:2011)
- Maximum continuous operating voltage U_c = 340 V AC
- Monobloc form factor
- Multiple-pole or single-pole products for assembly.

Product References

G



Acti9 iPRD1, PRD1

Surge arresters Type 1 or Type 1+2

Impulse discharge current I_{imp} :

- 12,5 kA for Acti9 iPRD1 12.5r
- 25 kA for:
 - Acti9 iPRD1 x25r
 - Acti9 PRD1 25r
 - Acti9 PRD1 Master
- 35 kA for Acti9 PRD1 35r



Certified for short-circuit current withstand, I_{sc} up to 75 kA (IEC 61643-11:2011). Acti9 iPRD1 F25r surge arrester version is a self-protected solution with integrated back-up Fuse (easy selection and installation). All others must be associated with an upstream fuse or circuit-breaker.

Acti9 iPRD1 C25r surge arrester version is an ultra-compact solution (50% space saving on DIN Rail).

Product References

J

These surge arresters are all available with withdrawal cartridges to allow quick replacement of damaged devices. They come with output contacts for remote signaling of end-of-life information (for Acti9 Smartlink or other input/output devices). They are suitable for 230/400 V AC 50/60 Hz networks, any earthing system: TT, TN-S, TN-C and IT (multi-poles or single-pole devices to be assembled). Acti9 PRD1 Master is also suitable for 400 V IT earthing system.



Application

Protect the electrical installations in all industrial and tertiary buildings against induced or conducted surges caused by indirect lightning strikes.



Application

- Protects electrical installations against transient overvoltage and surges caused by indirect lightning strikes in all industrial and tertiary buildings.
- They can also be used in residential sector with appropriate rated discharge current (20 kA).



Application

- Acti9 iPRD1, PRD1 Type 1 or Type 1+2 Surge arresters protect the electrical installations against induced or conducted surges caused by direct lightning strikes.
- The IEC/EN 62305-2 specifies the use of Type 1 or Type 1+2 Surge Protection Devices in **commercial and industrial buildings protected by a lightning conductor or a lightning rod**
 - Surge Protection Devices are recommended when there is **higher risk of direct lightning strikes**.

Acti9 Electrical circuit control



Product References

Acti9 iCT

Modular contactors up to 100 A

Fully consistent with the entire Acti9 range, our DIN rail contactors with electrical control help you control electrical circuits in industrial, residential and commercial buildings efficiently

- Rating: 16, 20, 25, 40, 63 and 100 A
- 1 to 4 poles: 1P, 2P, 3P, 4P
- Fully compliant with standards: EN 61095 and CEI 1095
- Excellent electrical endurance (O-C): 100,000 cycles
- Provides users with up to 100 switching operations a day
- 2 versions available with the option to use either standard or manually operated contactors
- Wide range of flexible optional auxiliaries including: state indication, interference filtering, dual control and time delay.



Application

- Complete control and monitoring solution for electrical circuits in all industrial, commercial and residential buildings
- Easily control and monitor single -or three- phase loads up to 100 A
- Effortlessly interface between the control gear and power circuits for final circuits such as lighting, heating, roller blinds, watering system, ovens, utility motors (ventilation, heat pump), and more.



Product References

Acti9 iTL

DIN rail Impulse relays

Designed with protection in mind and with a host of exclusive features, the Acti9 iTL DIN rail impulse relays, which are fully consistent with the entire Acti9 range, give you total electrical control of circuits in industrial, residential and commercial buildings.

- Class-2 insulation: providing enhanced protection for operators as well as unqualified personnel
- Rating: 16, 32 A
- 1 to 4 poles: 1P, 2P, 3P or 4P
- Easy wiring of multiple control points
- Wide range of control voltage: 230, 130, 48, 24 V AC; 110, 24, 12 V DC
- Lifetime - total number of switching operations (AC21): 200,000 for iTL 16 A; 50,000 for iTL 32 A
- Fully compliant with standards: EN 60-669-1 & EN 60-669-2-2
- Great choice of built-in or optional auxiliary functions including: state indication, centralised control, latched control, control for illuminated PB, step-by-step control and time delay.



Application

- Provides a complete control solution for electrical circuits in all industrial, commercial and residential buildings
- Lighting management via several easy wiring of multiple control points push buttons.

A

B

C

D

E

F

G

H

I

J

Acti9

Acti9 indication and tripping auxiliaries

A



Simplified electrical maintenance

Designed with protection and with a wide range of features, the Acti9 indication and tripping auxiliaries combine easy installation with high levels of functionality. It includes:

- Automatic reclosing, remote control, remote indication, and tripping
- VisiTrip for quick detection of faulty outgoers and reduced intervention time
- Clip-on assembly system for ease of use.

B

C

Product References

Acti9 auxiliaries for remote indication of the state of the device to which they are connected:

- Remote indication of "open" or "closed" state and of "tripped" state
- Instantaneous tripping when the control circuit is energized, de-energized, or if there is a dip in its supply voltage
- Time-delayed tripping (to cope with micro-breaks or brief voltage drops) when the control circuit is de-energized, or if there is a dip in its supply voltage
- Fail-safe emergency stop tripping.

D

E

Select the right offer:

- For basic applications (from 100mA to 6A), use commercial references A9A2690x
- For low current applications (from 2mA to 100mA), use commercial references A9A2691x
- For Smartlink systems with dedicated connectors, use commercial references A9A2689x.

F

G



Auxiliary RCA for remote control

- Remote electrical control (opening and closing) of circuit breakers with or without Vigi iC60 add-on RCD and with or without auxiliary.
- Circuit-breaker resetting after tripping, in full accordance with protection principles and regulations.
- Local control feature via an operating handle.

H

Product References

I



Auxiliary ARA for remote automatic reclosing

- Easily perform automatic reclosing of the associated protection device after tripping.
- Increase the availability of hard to access and isolated installations without supervision (mobile telephony systems, motorways, pumping stations, airports, railways, meteorological stations, service stations, automatic teller machines, public lighting, tunnels, etc.), by restoring them to operate without the need of personal intervention in the event of a transient fault (atmospheric disturbances, industrial overvoltages, etc.).

J

Product References



Application

- Industrial buildings
- Commercial buildings
- Critical building
- Data center
- Machine
- Infrastructure

Acti9 Comb Busbars



Acti9 comb busbar's primary function is to distribute electricity into a Low voltage distribution panel.

Product References

Acti9 range includes 3 main family of comb busbar, for iC40, iC60 and C120/NG125 ranges.

Being developed to work with dedicated devices, they are used to connect them optimizing space and time, keeping high level of performances.

Several type of configuration are covered, MCB's with or without Vigi and auxiliaries are available, for connection on top or bottom.



Application

- Critical buildings
- Commercial buildings
- Industrial buildings
- Buildings
- Data Center
- Industry.



Learn more about Acti9 Active and Acti9 ranges here



Scan or click on QR code

Offer

If you need more details about product references and availability, please check your local Schneider Electric contact <https://www.se.com/ww/en/work/support/country-selector/contact-us.jsp>

Easy9

- A
- B
- C
- D
- E
- F
- G**
- H
- I
- J



Protection devices MCB RCCB RCBO SW SPD



With everything from comb busbars to MCBs in the range, you are bound to find flexibility with the **Easy9** protection range, designed to provide you with maximum electrical protection in residential buildings.

Easy9 devices

Included in the range:

- Miniature circuit breakers (MCBs) for short circuit protection and overload protection
- Residual current circuit breakers (RCCBs) for earth leakage protection
- Residual current devices (RCBOs) for earth leakage protection, short circuit protection and overload protection
- Switches for Isolation
- Surge protection devices (SPD) for Surge protection
- Comb busbars for power distribution.

Application

Targeted towards the residential sector, the Easy9 range gives you electrical protection in residential buildings, and provides you with complete peace of mind, ease of use and reliability.

- Designed with the residential market in mind
- Ideally suited to individual and collective buildings.

Easy9 Incoming Devices



Switch-disconnectors



- Positive contact indication
- Suitable for isolation according to BSEN 60947-3 standard
- Manual control on front face by O-I lever

Characteristics

Main characteristics

Operating category	AC-22 A
Permissible rated short-time withstand current (I _{cw})	12 I _e , 1 second
Conditional rated short-circuit current (I _{nc})	5000 A
Rated short-circuit closing current (I _{cm})	15 I _e

Additional characteristics

Degree of protection (IEC 60529)	Device only	IP20
Endurance (O-C)	Mechanical	40 -100 A: 8500 cycles
	Electrical	40 -100 A: 1500 cycles
Operating temperature		-25°C to +60°C
Storage temperature		-40°C to +85°C
Tropicalisation (IEC 60068-1)		Treatment 2 (relative humidity 95% to 55°C)



RCCB residual current circuit breakers



- Positive contact indication
- Fault tripping indication on the front panel by the position of the handle
- (O - I engraved)

Characteristics

Main characteristics

Rated impulse withstand voltage (U _{imp})	4 kV
Conditional rated short circuit current (I _{nc} /I _{Δc})	4.5 kA or 6 kA

Additional characteristics

Degree of protection (IEC 60529)	Device only	IP20
Tropicalisation (IEC 60068-1)		Treatment 2 (relative humidity 95% to 55°C)
Operating temperature		-5°C to 60°C
Storage temperature		-40°C to +85°C

Easy9

Easy9 Devices

- A
- B
- C
- D
- E
- F
- G
- H
- I
- J



Miniature circuit breakers 6 kA

Easy9 circuit breakers combine the following functions:

- Circuit protection against short-circuit currents
- Circuit protection against overload currents.



- Fault tripping indication on the front panel by position of the handle
- (O-I engraved)

Characteristics

Main characteristics		
Voltage rating (Ue)		230/400 V AC
Operating frequency		50/60 Hz
Electrical feeding		By the top and bottom
Additional characteristics		
Degree of protection (IEC 60529)	Device only	IP20
Tropicalisation (IEC 60068-1)		Treatment 2 (relative humidity 95% to 55°C)
Operating temperature		-25°C to +60°C
Storage temperature		-40°C to +85°C

Easy9 Devices (continued)

RCBO residual current devices 6 kA

Certified compliant BS EN 61009-1.

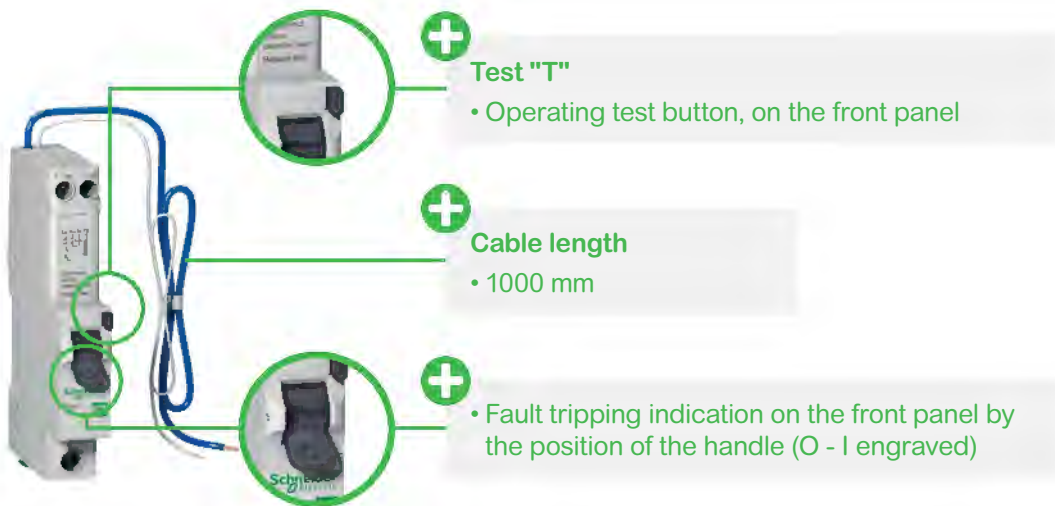

Characteristics

Main characteristics		
Endurance (O-C)	Electrical	4000 cycles
	Mechanical	10000 cycles
Passive, will not trip in the event of a voltage loss		
Additional characteristics		
Degree of protection (IEC 60529)	Device only	IP20
Overvoltage category (IEC 60364)		IV
Operating temperature		-15°C to +60°C
Storage temperature		-40°C to +85°C
Hazardous substances		RoHS 2003 compliant
Tropicalisation (IEC 60068-1)		Treatment 2 (relative humidity 95% to 55°C)



Learn more about Easy9 range here



Scan or click on QR code

Offer

If you need more details about product references and availability, please check your local Schneider Electric contact <https://www.se.com/ww/en/work/support/country-selector/contact-us.jsp>



Critical Power

Galaxy™ V Series

General overview	H-360
Technical specifications	H-363

Easy UPS series

General overview	H-364
Technical specifications	H-366





Galaxy™ V series: Uninterruptible power system

Well suited for a wide range of applications

- Edge, small, and medium data centers, and computer rooms
- Manufacturing facilities
- Telecommunication
- Commercial buildings
- Healthcare
- Transportation

A

B

C

D

E

F

G

H

I

J



New patented hybrid technology

Provides up to 97% efficiency in double conversion mode. Electricity savings in full protection mode at every load level.



Compact design optimised footprint

High-density technology and full front access make Galaxy VS a footprint saver well suited for confined spaces.



Battery flexibility, including Lithium-ion batteries

Increase availability and reduce TCO with long-life, intelligent energy storage.



99% efficient in patented EConversion™ mode

Recover your initial investment within twothree years through energy savings.



Maximum availability thanks to modular architecture

Critical system components built as modules for faster serviceability and fault tolerance. N+1 redundancy and scalability options available.



EcoStruxure IT

Anytime, anywhere monitoring and service support via smartphone app.



Leading performance

> Robust and flexible design ideal for demanding environments at maximum performance

Reduce your energy bill

> By using EConversion mode, significant savings are achieved every year on your electricity bill

Quick to install and fits

> Everywhere thanks to its compact design

Simple to maintain and fast to service

> Thanks to its modular architecture



Galaxy™ V series



Galaxy™ VS/VM/VX

10 to 1500 kVA 3 phase UPS for small and medium data centers and other business critical applications

Part of Galaxy V Series

Description

3 phase Uninterruptible Power System. Designed for fast and easy installation, this EcoStruxure-ready UPS features a wide operating temperature window and strong overload protection, all in a compact and lightweight footprint.

Characteristics

Normal AC supply input

- 10 to 1500 kVA
- 3:3
- Input voltage (V): 380 / 400 / 415 V (Three-phase + Neutral)
- Frequency (Hz): 40 – 70 Hz
- Input power factor: >0.99
- THDI: < 3% at full linear load

Output

- Nominal output voltage (V): 3:3 – 380/400/415 V
- Efficiency: Double conversion mode up to 96%
- Efficiency: ECOConversion mode up to 99%
- Overload capacity in normal operation 125% for 10 minutes and 150% for one minute^[1]
- Output voltage tolerance $\pm 1\%$
- Lithium capable

Connectivity

Communication interface RS485, USB, Dry contact, Modbus TCP/IP (SNMP optional) Five inch touchscreen LCD, status, and display console.

[1] Under 30°C degrees.

Learn more about Galaxy™ V series range here



Galaxy VS offer



Galaxy VM offer



Galaxy VX offer



Galaxy VS brochure



Galaxy VM brochure



Galaxy VX brochure

Scan or click on QR code



If you need more details about product references and availability, please check your local Schneider Electric contact <https://www.se.com/ww/en/work/support/country-selector/contact-us.jsp>

- A
- B
- C
- D
- E
- F
- G
- H**
- I
- J



A

B

C

D

E

10-600 kVA 3 phase UPS Business continuity made easy

Easy UPS 3 Series is an easy-to-install, easy-to-connect, easy-to-use, and easy-to-service.

F

G

Easy to use, connect, monitor, and manage

- User-friendly display interface supports easy configuration
- The optional network card enables:
 - Monitoring of UPS status remotely through a Web interface
 - Monitoring and management of the UPS status and performance through EcoStruxure IT's cloud-based and on-premise software suites, bringing you peace of mind.

H

Easy to maintain

- Front and rear access for service
- Quickly and easily replace the dust filter conveniently located behind the front door
- Schneider Electric service team available to make service easy and improve uptime with proper maintenance of your UPS and batteries.

J

Robust and competitive

- Easy UPS 3 Series brings predictability to utility costs:
 - Up to 96% efficiency in double conversion mode
 - Up to 99% efficiency in ECO mode
- Minimize your power losses and cooling requirements with up to unity power factor (kW=kVA)
- Protect your data center or electrical room with these fortifying features:
 - Embedded dust filter
 - Conformal coating
 - Operating temperature up to 40 °C
 - Wide input voltage range.

Proven performance

With an established customer base of over 100,000 satisfied customers, we have been providing business continuity around the world for more than 30 years. The Schneider Electric Easy UPS 3 Series is the easy-to-choose, easy-to-use power protection solution for today's connected businesses.

Over
120,000
satisfied customers

Easy UPS 3S/3M/3L

Description

3 phase Uninterruptible Power System. Designed for fast and easy installation, this EcoStruxure-ready UPS features a wide operating temperature window and strong overload protection, all in a compact and lightweight footprint.

Characteristics

Normal AC supply input

- 10 to 40 kVA (Internal or External batteries)
- 3:1 (10 to 30 kVA) 3:3 (10 to 600 kVA)
- Input voltage (V): 380 / 400 / 415 V (Three-phase + Neutral)
- Frequency (Hz): 45 – 65 Hz
- Input power factor: >0.99
- THDI:
 - linear load,
 - 5% non-linear load.

Output

- Nominal output voltage (V):
 - 3:1 – 220 / 230 / 240 V
 - 3:3 – 380 / 400 / 415 V
- Efficiency: Double conversion mode up to 96%
- Efficiency: ECO mode up to 99%
- Overload capacity in normal operation 130% for 10 minutes and 130-150% for one minute
- Output voltage tolerance $\pm 1\%$.

Connectivity

Communication interface RS232, RS485, USB, dry contact, Modbus TCP/IP, optional network card Control panel Multi-function LCD, status and display console.

Typical applications

- Small and medium data centers and computer rooms
- Manufacturing facilities
- Telecommunication
- Commercial buildings
- Healthcare
- Transportation

A

B

C

D

E

F

G

H

I

J

Easy UPS Series

A

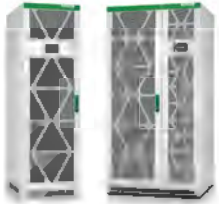

Easy UPS 3L

250-600 kVA, 400 V for commercial and industrial applications

The **Easy** UPS 3L is easy to configure, use, and service. This 250-600 kVA 3-phase UPS delivers high availability and predictability to medium and large commercial and industrial applications.

- Fault-tolerant design streamlines installation and service, compact footprint saves valuable real estate, and up to 96% efficiency brings predictability to your utility costs
- Competitive specifications, highly available parallel and redundant designs, and EcoStruxure™ connected via smartphone for your business continuity
- Start-up service to optimise your system's performance, quality, and safety
- Optional kit to achieve IP31 protection level
- Compatible with **Galaxy** Lithium-ion Battery Cabinets.

B

C

D

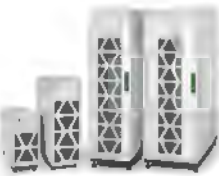

Easy UPS 3S

10-40 kVA, 208/400 V for small and medium data centers and other business critical applications

The **Easy** UPS 3S supplies power stability with robust electrical specifications and long-lasting performance to ensure your business continuity. Designed for fast and easy installation in the data centre or electrical room, this EcoStruxure™ connected UPS features a wide operating temperature window and strong overload protection, all in a compact and lightweight footprint. Schneider Electric recommends purchasing Start-Up Service to optimise your system's performance, quality, and safety.

E

F

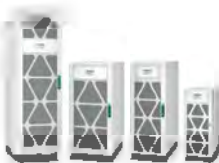

Easy UPS 3M

60-200 kVA, 400 V for small and medium data centers and other business critical applications

The **Easy** UPS 3M is easy to install, connect, and service 60-200 kVA (400 V) and 50-100 kVA (208 V) 3-phase UPS ideal for small and medium data centres and other business-critical applications. Its advanced product features, robust electrical specifications, and compact design ensure power stability, long-lasting performance, and business continuity. Designed for fast and easy installation, this EcoStruxure™ connected UPS features a wide operating temperature window and strong overload protection, all in a lightweight footprint. It's also compatible with **Galaxy** Lithium-ion battery cabinets. Start-up service is available to optimise your system's performance, quality, and safety.

G

H

Learn more about Easy UPS Series range here



Easy UPS 3S offer



Easy UPS 3M offer



Easy UPS 3L offer



Easy UPS Series brochure

Scan or click on QR code

If you need more details about product references and availability, please check your local Schneider Electric contact <https://www.se.com/ww/en/work/support/country-selector/contact-us.jsp>

Medium Voltage Switchgears components

General overview I-368

Medium Voltage switching devices

Vacuum Circuit-Breakers	I-373
SF ₆ Circuit-Breakers.....	I-375
Vacuum and SF ₆ contactors.....	I-376
Indoor load break switch, disconnecter and earthing switch....	I-377
Medium voltage Cradle.....	I-378
Medium voltage Fuses.....	I-379
Usefull links.....	I-380

Medium voltage Switchgear components



A

B

C

D

E

The widest range of components to meet all your requirements

Get the right level of partnership to fulfil your business ambition

Growth opportunities in the medium-voltage business sector are increasing, now more than ever. With access to the right resources, you can scale up your switchboard manufacturing operations and improve the quality of your services.

F

G

Latest MV components

Get high-quality MV components that comply with the latest engineering standards and gain privileged access to industry advances and cutting-edge solutions.

H

Dedicated portal access

Update your skillset with training on upcoming products and solutions and obtain tailored productivity tools to ensure higher output and efficiency.

Comprehensive technical support

Get dedicated help and advice on solutions that facilitate easier product integration and greater productivity for your business.

J

Medium voltage switchgear components

Electricity is getting more Digital & Sustainable, are you ready?

With the combined benefits of digitalisation, the Internet of Things and improved interoperability, there is significant potential for improvement in energy management.

Increased versatility enables faster adaptation to customer needs and rapid product configuration, while operational data analysis optimises operating conditions, predicts maintenance needs and enables better asset management.

As part of our commitment to sustainable and efficient energy, we also offer our partners innovative, compact and SF6-free solutions. This is in line with our aim to help companies gain a competitive advantage through smarter switchgear without compromising the environment.

AirPacT SF6-free switch and disconnecter



Decarbonize

Our offerings provide highly sustainable switchboards that promise longer durations of life. The use of Pure Air technology eliminates the use of SF6 gas, a known high potential Global Warming gas, removing the risks associated with changing regulations. Additionally, we continually strive to increase equipment efficiency and longevity with groundbreaking innovations such as the use of composite mechanisms, thereby promoting operational life extension.

PowerLogic P7 A major step forward for protection relays



Digitize

Given the pressing regulatory mandates and evolving customer needs, the need for highly efficient and durable installations has never been more significant. We provide the solutions that are engineered to boost the efficiency and optimize the operation service life of these installations. Constant information regarding the health of the power installation is crucial in extending its operational lifetime. Our service also significantly reduces downtime and intervention periods by foreseeing and managing potential failures.

See PowerLogic™ range page 174

EvoPacT HVX A revolutionary circuit breaker



Partner for the future

The wheels of Energy Transformation are now set in motion and we are prepared to extend our fullest support to our partners in this endeavor. The winners in this transformation will undoubtedly be the ones that are prepared and adaptable. We offer a multitude of supports to our partners, such as a thoroughly refreshed MV portfolio, unwavering focus on sustainability, and fostering of digital services. Moreover, our Pure Air technology, alongside connected devices, grants our panel builder partners a significant competitive edge. They are equipped to meet their customers' increasing demands for more efficient and sustainable installations.

- A
- B
- C
- D
- E
- F
- G
- H
- I
- J

Medium voltage switchgear components

Longlife partner for your customer

Support your customers to face the challenges of running efficient and durable electrical installation

For your end-user in industrial, commercial or infrastructure buildings power failure is the worst scenario that can happen . Business comes to a standstill, production and employees are idle.

Be informed 24/7 on health of your customer power installation

With digital services, as our partner you can leverage the power of connected equipment to effectively monitor electrical installations 24/7. This advanced approach enables to be informed proactively about any abnormal wear and tear.

Additionally, it also offers insights into the anticipated replacement of critical components, allowing to manage maintenance with improved efficiency and minimal disruption. Hence, digital services revolutionize equipment management, ensuring safety and prolonged operational lifespan.

Be your customer best advisor to maintain service continuity

As a trained and recognised partner of Schneider Electric, you will be able to recommend, propose or provide services to your customer to keep their installation operating at optimum levels for a long service life.

Become an expert in maintaining the availability and longevity of electrical distribution installations with field and digital services, you can now maximise revenue with additional service opportunities.

Gain more expertise and expand your business portfolio

- Differentiate from competitors with relevant services offerings
- Increase staff expertise with dedicated training
- Be the solution provider and trusted advisor your customer needs.



Medium voltage switchgear components

Benefit from Schneider Electric brand image and know-how



The experience of a world leader in Medium Voltage

Schneider Electric has been manufacturing MV cubicles for more than half century and has an installed base of millions of products and devices. The Schneider Electric brand is known worldwide and recognized.

A long history of innovation for a global offer

Based on this experience as a world leader, Schneider Electric has developed a large and comprehensive range innovative Medium Voltage devices employing field proven and latest breaking technologies. You benefit from a global leader's experience and know-how in electric distribution, automation and power and control.

Schneider Electric devices can easily benefit from advanced functionalities of communication and monitoring enabled by IoT devices to give final switchboard and installation valuable information and enhanced operability of the complete system.

Quality certification: ISO 9001 and ISO 14001

Every unit of Schneider Electric has a quality operating organization, with procedures recognized by many customers and official standard organizations. These procedures are:

- Uniform for all departments
- Recognized by numerous customers and official organizations



- A
- B
- C
- D
- E
- F
- G
- H
- I
- J

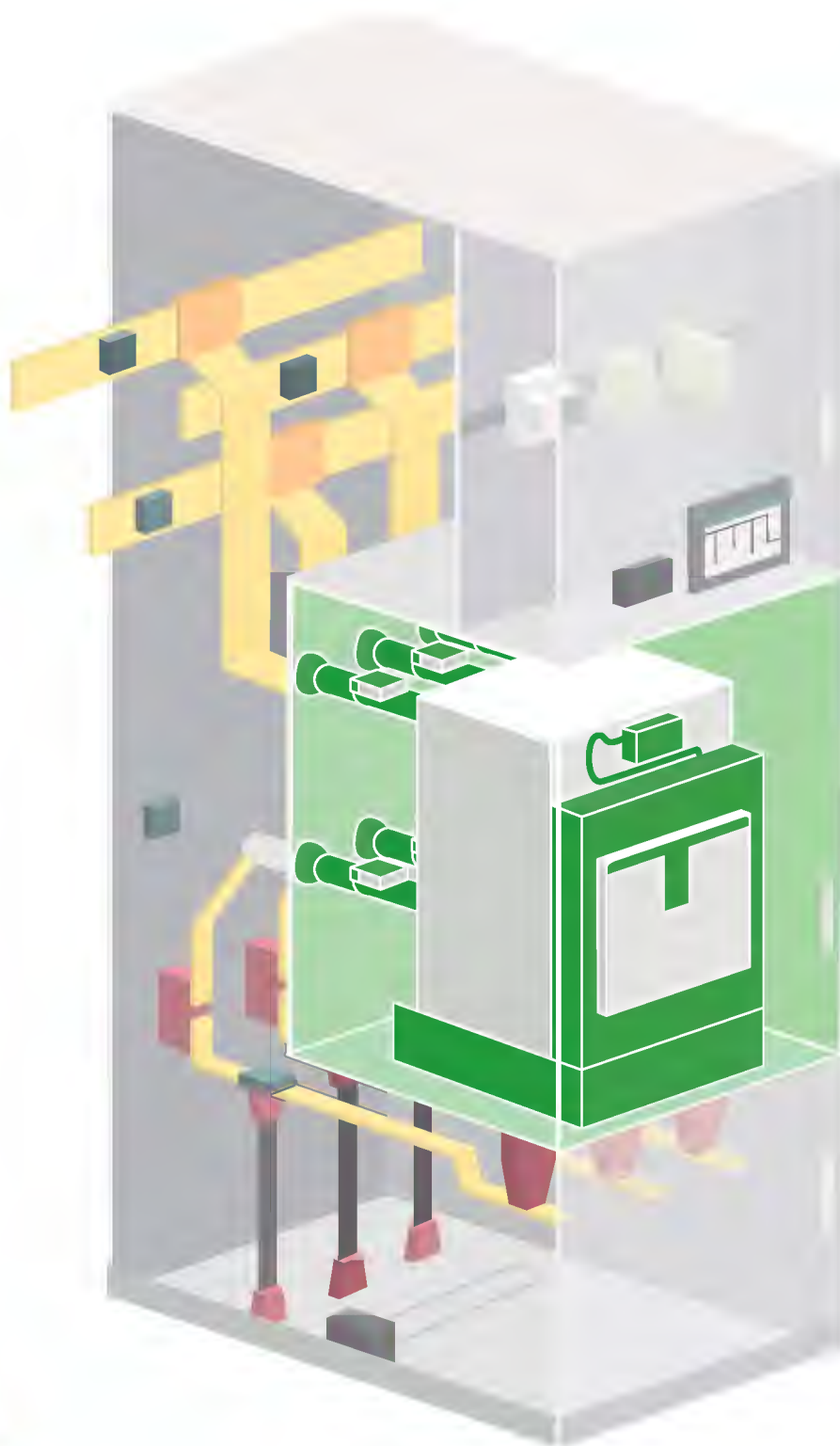

Medium Voltage switching devices

Circuit-Breakers

Vacuum Circuit-Breakers

Protection and operation of network

A revolutionary circuit breaker for MV distribution

EvoPacT HVX MV circuit breakers bring infrastructure, large industrial or commercial buildings, electro-intensive processes, or cloud and service providers into the future with IoT-enabled features that meet the needs of our All Digital, All Electric world.

By bringing us closer to our facilities' operations than ever before, EvoPacT HVX improves how we interact with our electrical systems, ushering in the digital revolution.



Longer service life

EvoPacT HVX is designed with more than 45 years of MV experience and manufactured using in-house, best-in-class components for a longer operational life.

- Proven to last three times longer than the industry standard for MV circuit breakers
- Built to withstand up to 30,000 mechanical and electrical operations
- Tested according to all major international standards, including IEC, ANSI/IEEE and GB

EvoPacT HVX



PMT10664



Rated voltage (kV)

24

Next Generation

Max. rated short-circuit current 31.5 kA

Max. rated current 2 500 A

Versions • Fixed • Withdrawable

Number of poles 3p

Mechanical operations cycles (ON/OFF) 30 000

Mounting Frontal

Mechanism Conventional spring

Standards • IEC • GB (Chinese) • ANSI

Benefits

- Embedded pole for better dielectric and environmental pollution withstand
- Operate smarter with innovative technology
- Reduce operational risk
- Built-in sustainability (Green Premium certified)
- Service enabler for Partners

• See video



Click to access to the product range



Circuit-Breakers

SF₆ Circuit-Breakers

Protection and operation of network

EvoPact LF  **EvoPact SF1**  **EvoPact SF2** 

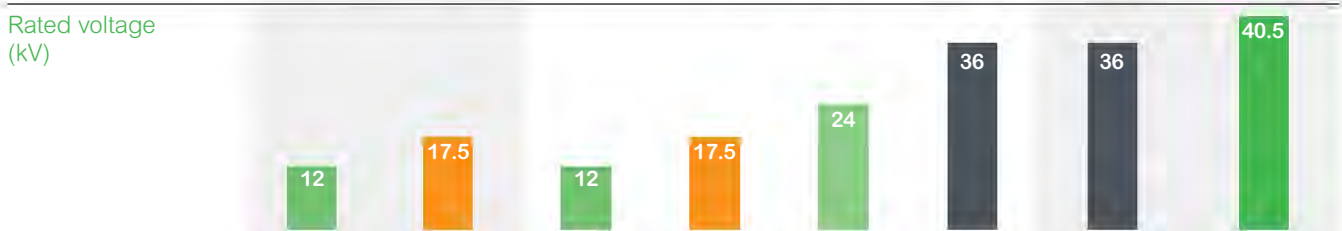

Max. rated short-circuit current	50 kA	40 kA	25 kA	25 kA	25 kA	25 kA	40 kA	31.5 kA
----------------------------------	-------	-------	-------	-------	-------	-------	-------	---------

Max. rated current	3 150 A			1 250 A			3 150 A	2 500 A
--------------------	---------	--	--	---------	--	--	---------	---------

Versions	<ul style="list-style-type: none"> • Fixed • Withdrawable 	<ul style="list-style-type: none"> • Fixed • Withdrawable 	<ul style="list-style-type: none"> • Fixed • Withdrawable
----------	---	---	---

Number of poles	3p	3p	3p
-----------------	----	----	----

Mechanical operations cycles (ON/OFF)	10 000	10 000	10 000
---------------------------------------	--------	--------	--------

Mounting	Frontal	Frontal and lateral	Frontal
----------	---------	---------------------	---------

Mechanism	Conventional spring	Conventional spring	Conventional spring
-----------	---------------------	---------------------	---------------------

Standards	<ul style="list-style-type: none"> • IEC • GOST 	<ul style="list-style-type: none"> • IEC 	<ul style="list-style-type: none"> • IEC
-----------	---	---	---

Benefits

- | | | |
|--|--|---|
| <ul style="list-style-type: none"> • Referenced product for Nuclear Power plants • Marine solutions certified • Seismic version available | <ul style="list-style-type: none"> • Integrated VIP trip unit (without auxiliary power supply) in SFset up to 24 kV • Well suited for capacitor bank and inductive load applications | <ul style="list-style-type: none"> • Particularly adapted for high voltage ratings and harsh environment • Well suited for capacitor bank and inductive load applications |
|--|--|---|

 [Click to access to the product range](#)

A

B

C

D

E

F

G

H

I

J

Contactors

Vacuum and SF₆ contactors

Protection and control of network

- A
- B
- C
- D
- E
- F
- G
- H
- I
- J

Vacuum Contactor

SF₆ Contactor

CBX  **CVX**  **Rollarc** 

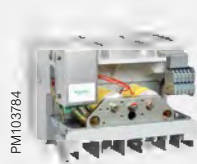

	CBX		CVX		Rollarc	
Rated voltage (kV)	7.2	12	7.2	12	7.2	12
Max. rated short-circuit current	6 kA	4 kA	6 kA (50 kA in conjunction with fuses)	4 kA (50 kA in conjunction with fuses)	10 kA	8 kA
Max. rated current	400 A (AC4)	315 A (AC4)	400 A (AC4)	315 A (AC4)	400 A (AC4)	
Versions	<ul style="list-style-type: none"> • Fixed 		<ul style="list-style-type: none"> • Withdrawable version equipped with DIN or BS fuses • Optional on board auxiliary voltage transformer 		<ul style="list-style-type: none"> • Basic • Fixed • Withdrawable 	
Number of poles	1p - 3p		3p	3p	3p	3p
Mechanical operations cycles (ON/OFF)	<ul style="list-style-type: none"> • 300 000 (mechanical latch) • 1 000 000 (magnetic held) 		<ul style="list-style-type: none"> • 300 000 (mechanical latch) • 1 000 000 (magnetic held) 		<ul style="list-style-type: none"> • 100 000 (mechanical latch) • 300 000 (magnetic held) 	
Mechanism	Magnetic holding or mechanical latch		Magnetic holding or mechanical latch		Magnetic holding or mechanical latch	
Standards	<ul style="list-style-type: none"> • IEC • GB (chinese) 		<ul style="list-style-type: none"> • IEC • GB 		<ul style="list-style-type: none"> • IEC 	
Benefits						
	Version available for capacitor banks: <ul style="list-style-type: none"> • 1 pole version available for neutral Earthing • Specific version available for capacitor banks 		<ul style="list-style-type: none"> • LV supply thanks to optional on board VT • High short circuit breaking capacity in combination with fuses • Cradle available (consult us) 		<ul style="list-style-type: none"> • Reference product in SF₆ contactor market • Nuclear powerplant & Marine applications • Soft breaking, suited for capacitor bank, power transformers and motors applications 	

 [Clic to access to the product range](#)

Medium Voltage switching devices

Switches and Disconnectors

Indoor load break switch, disconnector and earthing switch

SF₆-free switch & disconnector

SF₆ switch & disconnector

Earthing switch

AirPacT **LBSkit** **EISC** **Earthing switch 17/24 kV**



PM109061



PE56373



PM105560



PM108546

Function Indoor load break switch, disconnector and accessories Earthing switch Earthing switch

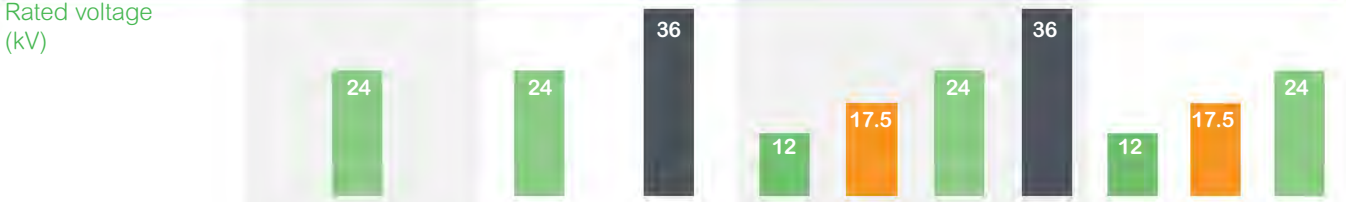

Max. rated short-circuit current 25 kA/1 s 25 kA/1 s 25 kA/1s 31.5 kA 31.5 kA 31.5 kA 25 kA 31.5 kA 50 kA 31.5 kA

Max. rated current 1 250 A 1 250 A 1 250 A

Pole center distance

Device	Pole Center Distance (mm)
AirPacT	165, 175, 210, 215, 250
LBSkit	210, 215, 250, 275, 300
EISC	165, 210, 215, 250, 275, 300
Earthing switch 17/24 kV	160, 200-240, 240

Mechanical operations cycles (ON/OFF) 10 000 operations 1 000 O/C cycles (Class M1) 1 000 cycles

Standards IEC IEC IEC IEC 62271-102





Benefits

- Green Premium
 - Insensitive to environment
 - Reduced maintenance
 - Easy & flexible integration
 - See video
- Insensitive to environment
 - Reduced maintenance
- Earthing switch for a wide range of rated voltages
- Simple and robust design easy to adapt with a large choice of options

Click to access to the product range

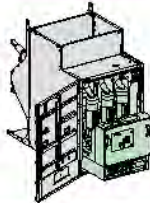

Cradle

	L-Frame Cradle	M1-M2 Cradle	MC Cassette
			
Function	Integration of switching device	Integration of switching device	Integration of switching device
Rated voltage (kV)	12, 17.5, 24	36, 40.5	7.2, 12, 17.5
Max. rated short-circuit current	50 kA, 31.5 kA	40 kA, 31.5 kA	50 kA
Max. rated current	3 150 A, 2 500 A	2 500 A, 1 250 A	3 150 A
Recommended cubicle width	650 - 1 000 mm, 800 - 1 000 mm	1 100 mm	570 - 900 mm
Integration of switching device	EvoPact HVX Embedded Pole + EasyPact EXE	EvoPact SF	EvoPact LF + EasyPact EXE
			
Version	With and without earthing switch	Without earthing switch	With earthing switch in option
Benefits	Fully assembled by Schneider Electric	Two different arrangements for HV connection using the upper and lower bushings	Full type tested solution including internal arc protection with MV door

 Click to access to the product range

Function

Protection to Medium Voltage distribution devices (from 3.6 to 36 kV) from both the dynamic and thermal effects of short-circuit currents

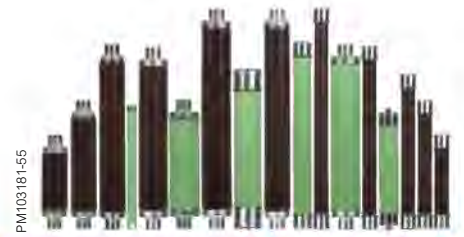

	Fusarc CF	Solefuse	Tepefuse	MGK
Rated voltage (kV)	3.6, 7.2, 12, 17.5, 24, 36	7.2, 12, 24, 36	12, 24	7.2
Max. rated short-circuit current	Up to 63 kA	Up to 50 kA	Up to 40 kA	Up to 50 kA
Max. rated current	Up to 250 A	Up to 125 A	Up to 0.3 A	Up to 250 A
Applications	<ul style="list-style-type: none"> • Motors • Power Transformers • Capacitors • Metering Transformers 	<ul style="list-style-type: none"> • Power Transformers • Capacitors 	<ul style="list-style-type: none"> • Voltage Transformers 	<ul style="list-style-type: none"> • Motors
Standards	<ul style="list-style-type: none"> • IEC 60282-1 • DIN 43625 • VDE 0670-402 	<ul style="list-style-type: none"> • IEC 60282-1 • UTE C64200, C64210 	<ul style="list-style-type: none"> • IEC 60282-1 • UTE C64200, C64210 	<ul style="list-style-type: none"> • IEC 60282-1
Benefits	<ul style="list-style-type: none"> • High breaking capacity • High current limitation • Low I²t values • Low breaking overvoltage • Low dissipated power • For indoor and outdoor applications • With a thermal striker 			

For additional information consult our MV fuses catalogue (ref. AC0479EN)



Usefull links

Learn more on our Medium Voltage products and technology to extend your business opportunities

- A
- B
- C
- D
- E
- F
- G
- H
- I
- J



Helping you design MV products according to IEC standards

- Our talented electrical distribution experts share their industry-leading knowledge of technological developments and evolving medium-voltage standards.

MV Technical Guide



Helping protect people and systems from arc flash in medium voltage equipment

- Easy to understand approach on arc flash systems installed in MV switchgear

Arc Flash eGuide



Improving your business with digital self-service

- Digital self-service helps your business improve flexibility and productivity, allowing you to quickly adapt to customer needs in changing times.

Digital Life Cycle eGuide



Schneider Electric EcoFit™ Life Extension Essential Catalog

- Discover in a single catalog all assets and services to modernize existing MV and LV installations by adding sensors and communication capabilities.

Catalog EcoFit™ Life Extension Essential



Leaflet EcoExpert Certified basic

- We offer Panel Builders an easy way to get into Medium Voltage business.

Pre-assembled MV Switchgear



Power Services Catalogues

- Download EcoXpert Power Services catalog: Enhance your portfolio, strengthen customer loyalty, and drive your business forward by leveraging our specialized services that complement your expertise as a Panel Builder.

Power Services Catalog



Learn more about Medium Voltage Switchgear range here



Offer



Catalogue

Scan or click on QR code

If you need more details about product references and availability, please check your local Schneider Electric contact <https://www.se.com/ww/en/work/support/country-selector/contact-us.jsp>

Incoming Protection

PowerLogic P1	
General overview	J-382
Product description - PowerLogic P1F	J-386
Product description - PowerLogic P1V	J-387
PowerLogic P3	
General overview	J-392
General characteristics PowerLogic P3 Standard	J-396
General characteristics PowerLogic P3 Advanced	J-398
PowerLogic P5	
General overview	J-400
General characteristics	J-404
Usefull links	J-405
PowerLogic P7	
General overview	J-406
PowerLogic A1 and A3	
General overview	J-412
General characteristics	J-416
PowerLogic T300	
General overview	J-418
General characteristics	J-422



- A
- B
- C
- D
- E
- F
- G
- H
- I
- J



PowerLogic™ P1

Simple, reliable, and easy-to-use protection relays



Built on over a century of experience in medium-voltage protection relays, the new PowerLogic P1 is designed to meet your customers' needs for electrical protection, connectivity and everyday ease-of-use.

PowerLogic P1 is designed to be an effective solution for simple applications like overcurrent, earth-fault, voltage and frequency, working with traditional CTs or LPCTs. Suited for basic distribution applications in commercial and industrial buildings, industrial settings or distribution utilities or as LV applications when ANSI functions are required. Ideal for back-up protection in new installations or in retrofit applications when replacing legacy relays.

Reduce time and costs with simple installation, setting and configuration.

Get more benefits with digital, reliable and efficient PowerLogic P1:

- Single function voltage or current protection
- Incomer, feeder or transformer applications
- Simple to order, install and operate

Take PowerLogic protection relays further with EcoStruxure™

EcoStruxure, Schneider Electric's IoT-enabled, open and interoperable architecture and platform, brings together Connected Products, Edge Control, and Apps, Analytics & Services. EcoStruxure connected products deliver enhanced value around safety, reliability, efficiency, sustainability, and connectivity.

450 000

EcoStruxure systems deployed since 2007 with the support of our 9,000 system integrators

EcoStruxure ready



Efficient asset management

Help boost your efficiency and participate to reduce downtime using predictive maintenance tools



24/7 connectivity

Make better informed decisions with real-time data that's available everywhere, anytime



Enhanced safety

Advanced features designed-in based on well-known designs, experience and technology

EcoStruxure™ Innovation At Every Level

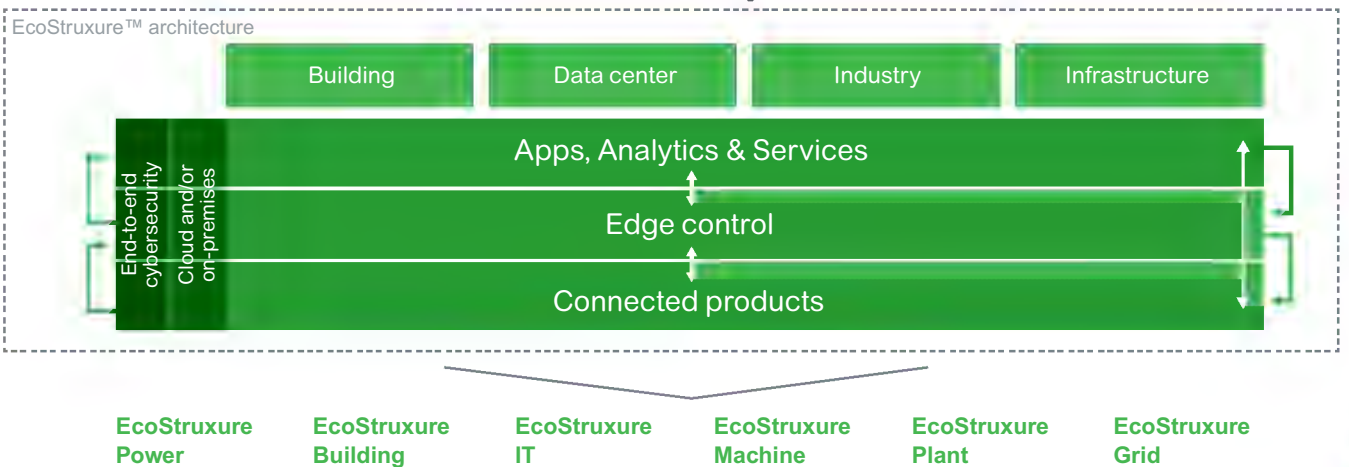

PowerLogic™ P1

The PowerLogic P1 relays are suitable for the applications where overcurrent and/or earth-fault and voltage protection are required.

PowerLogic P1F and P1V models can be applied to medium and low voltage electrical systems.

PowerLogic relays provide features for easy adaptation to different applications and operation conditions. The P1F and P1V models can be fully configured manually, without using setting software.

Alternatively, eSetup Easergy Pro (or PowerLogic Studio) setting software allows configuration parameters to be modified for a specific application via the USB port.

IEC 60870-5-103 and Modbus RTU integrated communication protocols are available for flexible integration into most substation control or DCS systems.

Close and trip commands can be executed via functional key on the front panel, default menu window, DCS/SCADA system (RS485) or configured binary input. Simpler operation and maintenance with the EcoStruxure™ Power

Three level password gives proper access rights for secure maintenance of the relay.

As a device housed in a small sized flush-mountable case, the P1V and P1F models can be easily installed in all modern, dimension-focused switchgear panels, up to IP54 ingress protection degree.

The relay can be also considered as a cost-effective answer to retrofit demands of older substations.

In P1F we have, for overcurrent protection functionality, selectable measuring criteria: True RMS and/or fundamental frequency (Fourier) current measurements allow to increase selectivity and adapt to the application.



ANSI or IEC



Ideal for industrial buildings, distribution utilities and LV applications (if ANSI functions are needed)



CE markings as per Directive 93/98/CEE

ISO/EHS/OHSAS certified manufacturing facility reinforces product quality and reliability. Independent lab reports available for CE.

Features and options

	 P1F	 P1V
Current	3CT + 1CT	–
Voltage	1VT (option)	3VT or 4VT ^[1]
Overcurrent protection	<input checked="" type="checkbox"/>	–
Directional earth-fault protection	<input checked="" type="checkbox"/> ^[1]	–
Voltage protection	–	<input checked="" type="checkbox"/>
Frequency protection	–	<input checked="" type="checkbox"/> ^[1]
Inputs	Up to 8	Up to 6
Outputs	Up to 8	Up to 8
Programmable LEDs	6	6
CB control keys	<input checked="" type="checkbox"/>	<input checked="" type="checkbox"/>
Communications	USB* & RS485*	USB* & RS485*
Records	<input checked="" type="checkbox"/> ^[1]	<input checked="" type="checkbox"/> ^[1]
Display	LCD 32 x 2	LCD 32 x 2

[1] Depending on the model

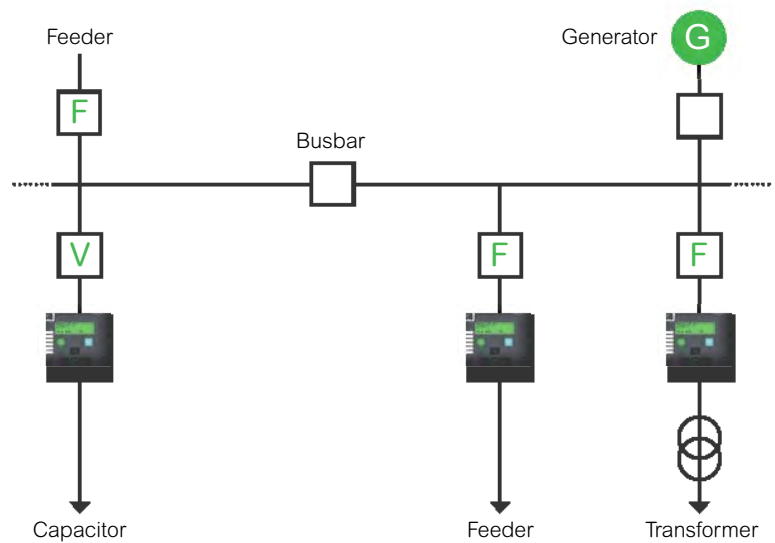

PM107253



Main Features

The following functions are generally available in all devices:

- Operate in 1, 2, or 3-phase arrangement.
- Two setting groups, selected from the relay menu, binary input or SCADA/DCS.
- Flush mounted case.
- Fundamental and True RMS (within a frequency range from 10Hz to 1kHz) phase current value measurement.
- 9 button keypad to input settings, configure the relay and close and trip command and display (graphical).
- Fault record for most recent trips.

The P1F protection relays are comprised of a suite of protection functions as well as auxiliaries. Each function can be individually configured or disabled to suit every kind of application.

All available functions, including protection, automation, communication, LEDs, inputs and outputs, are easily programmable through the user-friendly human machine interface and/or the eSetup Easergy Pro software interface.

The graphical LCD provides the user with key information (faults, measurements, settings, etc.). The menus have a pull-down structure for easy use and quick access to any data. User can switch HMI language directly through the front panel.

8 LEDs (6 freely configurable) indicate the correct operation of the relay as well as other information regarding the protection of the electrical system.

The hardware architecture and software algorithms have been designed to operate on very short failure detection times. Tripping occurs typically within 40 ms.

Easy to use with EcoStruxure™ Power Operation.

+ Customer benefits

> Easy to use

Easy to use with EcoStruxure™ Power Operation.
Help to economize your time and money

> Flexible

Help to optimize your investment.

> Reliable

Help to reduce risk and power outage.
Strive for sustainability.

Application

PowerLogic P1F numerical overcurrent protection relay provides an optimized solution. Typical applications are:

- Utility and industrial substation fitted with cost-optimized MV switchboards
- Retrofit relays of old technology, particularly during installation of DCS systems
- Transformers, incomers, bus couplers, overhead lines and underground cables on MV systems
- Neutral system protection (insulated, solid and resistance earthed)
- LV substations.



Main Features

PowerLogic P1V is a basic numerical relay that helps to provide reliable and effective voltage and frequency protection with automation, control and measurement functions. It may be applied to all low voltage or medium voltage applications as a primary or back-up protection device.

PowerLogic P1V has always been strongly linked to flexible and easy-to-use protection relays. It inherits the well known MiCOM Px10 and VAMP 11V series. With attention to simplicity and cost effectiveness, the PowerLogic P1V becomes the reference for the most efficient devices for standard protection applications.

Thanks to the cost to functionality ratio, the PowerLogic P1V is an innovative solution that is tailored to user's needs and can be applied in any type of low or medium voltage network where voltage or frequency protection is required.

+ Customer benefits

> Easy to use

Easy to use with EcoStruxure™ Power Operation
Help economize your time and money

> Flexible

Help to optimize your investment.

> Reliable

Help to reduce risk and power outage.
Strive for sustainability.

Many selectable options embedded in the relay offer a high level of flexibility in terms of application and maintenance. VT ratio, communication protocol, HMI language or independent settings of hysteresis for under or over-voltage protection are all selectable in the menu. Moreover, only 3 relay models are used to accommodate specific applications and operating conditions. This approach helps optimize the protection to the requirements and helps minimize wasted functionality and cost. A unique list of only 10 model variants (type designations) cover all model, voltage input range and auxiliary power supply options, meaning that ordering and spares holding is simplified for ease of use.

Switchable serial communication (IEC 60870-5-103 or Modbus) allows the device to connect to almost any kind of SCADA system. A front USB port and multilingual HMI makes PowerLogic P1V user-friendly with reduced maintenance costs.

Easy to use with EcoStruxure™ Power Operation.

PowerLogic P1V is housed in a standard flush mounting case which can be complemented by two optional accessories:

- Wall mounting adaptor
- Transparent plastic front cover to limit unauthorized access.

Application

PowerLogic P1V is a basic numerical relay provides reliable and effective voltage or voltage and frequency protection with automation, control and measurement functions. Typical applications are:

- LV or MV applications
- Primary or back-up protection device
- Retrofit of electromechanical relay

PowerLogic™ P1



Protection functions	ANSI code	PowerLogic P1F							PowerLogic P1V		
		P1F1L	P1F1L+	P1F1N	P1F1B	P1F1A	P1F1E,C,T	P1F1E+,C+,T	P1V1L	P1V1N	P1V1A
Phase overcurrent	50/51	3	3	3	3	3	3	3	-	-	-
Earth fault overcurrent	50N/51N	2	2	2	2	2	3	3	-	-	-
Negative sequence overcurrent	46	-	-	-	-	-	1	1	-	-	-
Cur. unbalance, broken conductor	46BC	-	-	-	-	-	1	1	-	-	-
Thermal overload	49	-	-	1	1	1	1	1	-	-	-
Breaker failure	50BF	1	1	1	1	1	1	1	-	-	-
Switch On To Fault (SOTF)	50HS	-	-	-	1	1	1	1	-	-	-
Directional earth-fault o/c	67N/21Y*	-	-	-	-	-	-	2	-	-	-
Magnetizing inrush detection	68F2	-	-	-	-	1	1	1	-	-	-
Auto-recloser based on current	79	-	-	-	-	-	4	4	-	-	-
Overvoltage	59	-	-	-	-	-	-	-	3	3	3
Undervoltage	27	-	-	-	-	-	-	-	3	3	3
Positive sequence undervoltage	27P	-	-	-	-	-	-	-	-	-	2
Negative sequence overvoltage	47	-	-	-	-	-	-	-	-	2	2
Neutral voltage displacement	59N	-	-	-	-	-	-	-	-	3	3
Derived Vo sequence overvoltage	59N	-	-	-	-	-	-	-	3	3	3
VT supervision	60FL	-	-	-	-	-	-	-	-	1	1
Auto-recloser based on Frequency	79V	-	-	-	-	-	-	-	-	-	1
Over or under frequency	81	-	-	-	-	-	-	-	-	-	6
Rate of change of frequency (RoCoF)	81R	-	-	-	-	-	-	-	-	-	1
Lockout	86	1	1	1	1	1	1	1	1	1	1
Cold load pick-up		1	1	1	1	1	1	1	-	-	-
Blocking logic		-	-	-	1	1	1	1	-	1	1
IDMT curves		21	21	21	21	21	21	21	15	15	15
Setting groups		2	2	2	2	2	2	2	2	2	2
Auxiliary timers		-	-	-	4	4	4	4	-	3	3

[*] E/F Protection can be set as directional E/F protection or admittance protection

	PowerLogic P1F									PowerLogic P1V		
Hardware	P1F1L	P1F1L+	P1F1N	P1F1B	P1F1A	P1F1E,C	P1F1E+,C+	P1F1T	P1F1T+	P1V1L	P1V1N	P1V1A
Phase current inputs - Conventional CTs	3	3	3	3	3	3	3	-	-	-	-	-
Phase current inputs - LPCT	-	-	-	-	-	-	-	3	3	-	-	-
Residual current inputs	1	1	1	1	1	1	1	1	1	-	-	-
Phase voltage inputs	-	-	-	-	-	-	-	-	-	3	3	3
Neutral voltage inputs	-	-	-	-	-	-	1	-	1	-	1	1
Digital inputs	-	-	-	4	4	8	8	8	8	-	2	6
Digital outputs	3+WD	3+WD	5+WD	3+WD	7+WD	5+WD	5+WD	5+WD	5+WD	3+WD	5+WD	7+WD
USB front port with powering	-	-	1	1	1	1	1	1	1	-	1	1
RS485 rear port	-	1	1	1	1	1	1	1	1	-	1	1
Control functions												
Local/remote function	-	■	■	■	■	■	■	■	■	-	■	■
Local control with I/O keys	■	■	■	■	■	■	■	■	■	■	■	■
Remote control with RS485	-	■	■	■	■	■	■	■	■	-	■	■
Remote control with digital inputs	-	-	-	■	■	■	■	■	■	-	-	■
Time Synchronization with digital input	-	-	-	-	-	■	■	■	■	-	-	■
Auxiliary timers	-	-	-	4	4	4	4	4	4	-	3	3
Measurement												
RMS current values	■	■	■	■	■	■	■	■	■	-	-	-
RMS voltage values	-	-	-	-	-	-	-	-	-	■	■	■
Frequency	-	-	-	-	-	-	-	-	-	-	-	■
Positive sequence of voltage	-	-	-	-	-	-	-	-	-	-	-	■
Negative sequence of voltage	-	-	-	-	-	-	-	-	-	-	■	■
Thermal overload	-	-	■	■	■	■	■	■	■	-	-	-
Inrush current ratio	-	-	-	-	■	■	■	■	■	-	-	-
Positive sequence of current IS1	-	-	-	-	-	■	■	■	■	-	-	-
Negative sequence of current IS2	-	-	-	-	-	■	■	■	■	-	-	-
Relative IS2/IS1	-	-	-	-	-	■	■	■	■	-	-	-
Phase Peak Demand Current Values	■	■	■	■	■	■	■	■	■	-	-	-
Logs and Records												
Tripping context record	20	20	20	20	20	20	20	20	20	20	20	20
Sequence of event record	-	200	200	200	200	200	200	200	200	-	200	200
Disturbance record	-	-	-	-	4 s	4 s	4 s	4 s	4 s	-	-	4 s
Monitoring functions												
Trip circuit supervision	-	-	-	-	1	1	1	1	1	-	-	-
Circuit breaker monitoring & diagnostics	-	-	-	-	1	1	1	1	1	-	-	1
Counters	-	-	-	-	1	1	1	1	1	-	-	1
Self-supervision (WD)	■	■	■	■	■	■	■	■	■	■	■	■

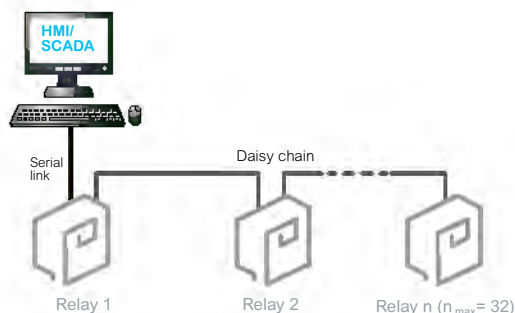

General characteristics

PowerLogic™ P1
Communication

Connection to SCADA using serial line

This architecture allows you to connect HMI/SCADA to a set of PowerLogic protection relays using a multi-drop serial communication link with client-server communication.

Available protocols: Time synchronisation protocol:

- Modbus RTU
- IEC 60870-5-103
- Minute pulse

Connection to SCADA using serial lines and legacy protocols

This architecture allows you to connect HMI/SCADA to a set of PowerLogic protection relays using a multi-drop serial communication link with client-server communication protocols such as Modbus-RTU or IEC 61870-5-103.

The RS485 serial communication port of the PowerLogic protection relay enables simple daisy chaining suited for 2-wire. A termination module is plugged into the last connection.

Data exchanged between
PowerLogic™ P1F / P1V and SCADA

Protocol	Modbus	IEC 60870-5-103
Real time data		
Measurement	■	■
Alarms and status	■	■
Controls	■	■
Time-stamped events	■	■
Historical data		
Disturbance records	■	-
Sequence of event record files	■	-
Setting management		
Setting group change	■	■
Settings	■	-

Engineering system

eSetup Easergy Pro

eSetup Easergy Pro (or PowerLogic Studio) can be connected to a single PowerLogic protection relay on the front USB port.

eSetup Easergy Set allows you to prepare the configuration of the relay without having any physical relay. For this purpose, eSetup Easergy Pro provides the latest version of the configuration description file directly from the web.

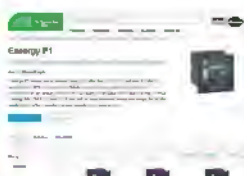

Learn more about
PowerLogic P1
range here



Offer



Catalogue

Scan or
click on
QR code

If you need more details about product references and availability, please check your local Schneider Electric contact
<https://www.se.com/ww/en/work/support/country-selector/contact-us.jsp>





PowerLogic P3

Network protection relays

PowerLogic P3 is a complete range of protection relays for medium voltage applications, including feeder, motor, transformer, and generator protection. It embeds all the latest communication protocols on serial or Ethernet links.

Based on more than 100 years of experience in network protection relays, PowerLogic P3 benefits from the reliability of Sepam, MiCOM and Vamp.



[Check the brochure](#)



Scan or click on QR code



Unparalleled Efficiency



Better Connectivity



Enhanced Safety

- Simple selection and ordering with EcoReal MV
- Simplified configuration with the new eSetup Easergy Pro setting tool
- Faster delivery with on-the-shelf availability of standard configurations.

- Simpler operation and maintenance with the EcoStruxure™ Power Device app
- 9 communication protocols in one box, including IEC 61850
- Increased number of inputs and outputs for more possibilities.

- Embedded arc protection
- Built-in virtual injection testing
- Compliant with international standards (i.e. IEC 60255-1).

Range overview

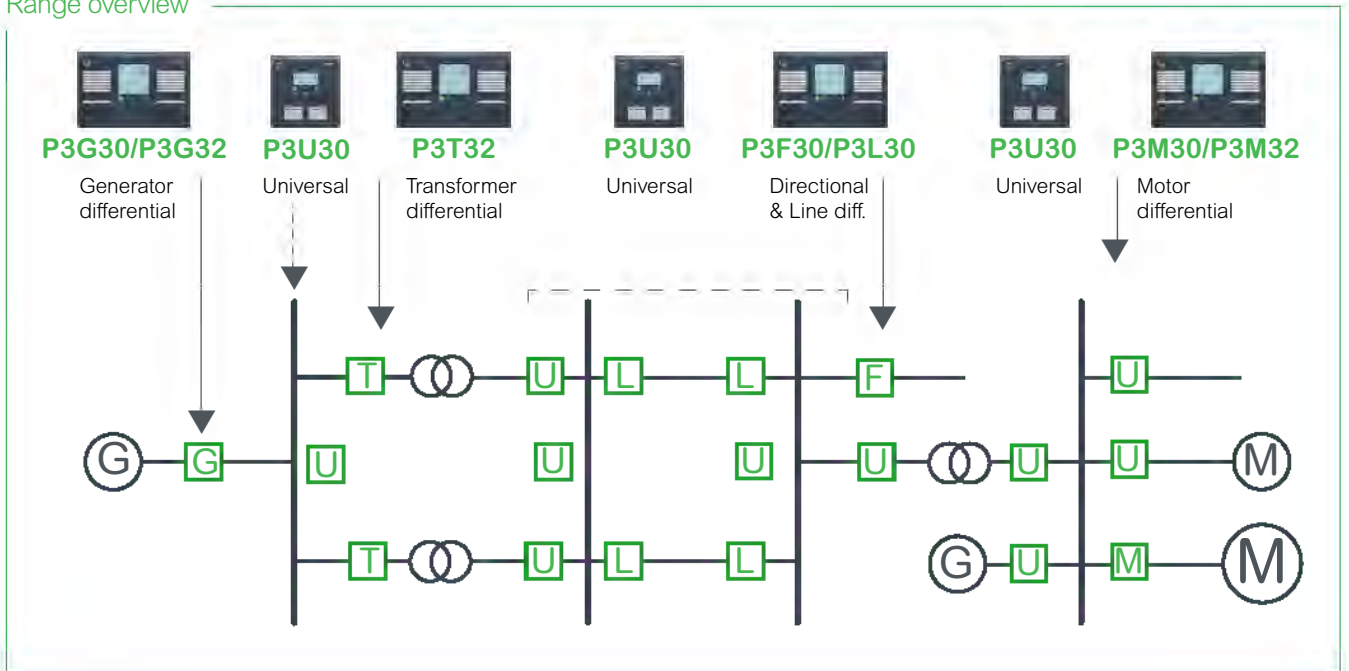

General overview

PowerLogic P3



PowerLogic P3 Standard



PowerLogic P3 Advanced

PowerLogic P3 is a family of digital protection relays for distribution networks dedicated to:

- **Buildings and Industry:**
 - Retail
 - Hotels
 - Education and research
 - Transportation
 - Industrial buildings
- **Utilities - Energy distribution.**
- **Large sites:**
 - Mineral and Metals
 - Water.

PowerLogic P3 protection relay is based on proven technology concepts and developed in close cooperation with customers, so it's built to meet your toughest demands. It's available in two sizes to best fit your needs:

- The PowerLogic P3 Standard combines protection functions such as directional earth fault for feeder and motor protection in a one-box solution
- The PowerLogic P3 Advanced features a modular design that allows user-defined conventional protection and arc flash protection solutions in both new and existing power distribution systems.

PowerLogic products are designed to be user friendly, a feature that is proven in our customer reports day after day. You'll benefit from features that include:

- A complete set of protection functions, related to the application
- Arc detection (PowerLogic P3 Advanced)
- Dedicated circuit breaker control with single-line diagram, push buttons, programmable function key and LEDs, and a customizable alarm
- Multilingual HMI for customized messaging
- Settings tool relay management software for setting parameters, configuring, and network fault simulation
- Both serial and Ethernet communication, including redundancy
- IEC 61850 standard Ed.1 & Ed.2.

Take the PowerLogic P3 further with EcoStruxure™

EcoStruxure, Schneider Electric's IoT-enabled, open and interoperable architecture and platform, brings together Connected Products, Edge Control, and Apps, Analytics & Services. EcoStruxure connected products deliver enhanced value around safety, reliability, efficiency, sustainability, and connectivity.

450 000

EcoStruxure systems deployed since 2007 with the support of our 9,000 system integrators

EcoStruxure ready



Efficient asset management

Help boost your efficiency and participate to reduce downtime using predictive maintenance tools



24/7 connectivity

Make better informed decisions with real-time data that's available everywhere, anytime



Enhanced safety

Advanced features designed-in based on well-known designs, experience and technology

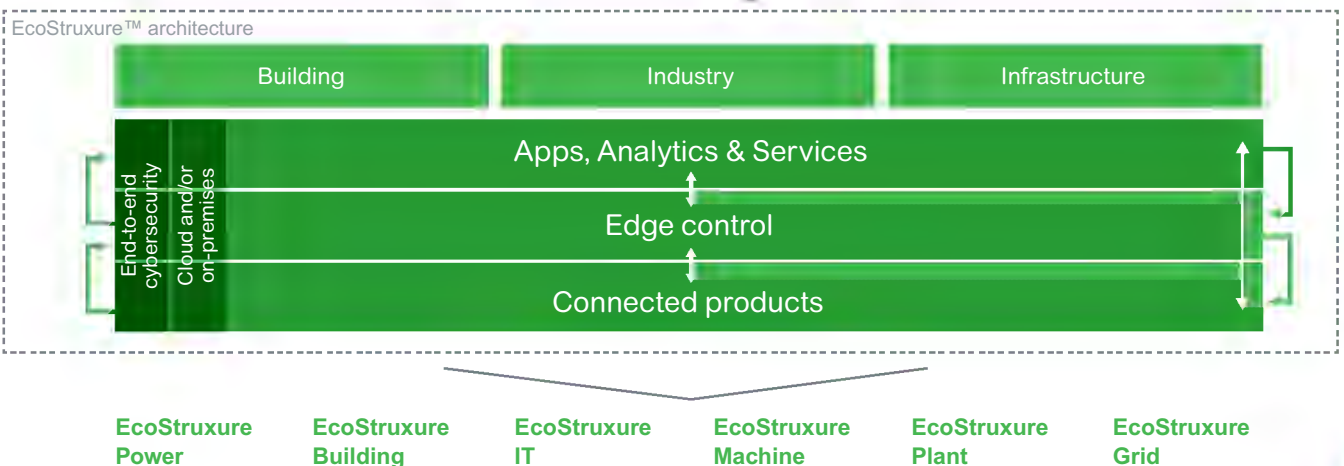

General characteristics

PowerLogic P3 Standard

The PowerLogic P3 Standard protection relay has been developed to meet your standard protection needs for building, distribution utilities, and industrial applications.

Thanks to its optimized and flexible design, the PowerLogic P3 Standard provides an excellent solution for various protection applications.

The user-friendly PowerLogic P3 Standard brings greater efficiency to your operations by enabling rapid ordering, configuration, and operations for an unparalleled digital experience

PowerLogic P3 Standard at a glance

Universal

- All-in-one box with feeder, transformer, and motor protections
- All communication protocols embedded on serial and Ethernet links including IEC 61850 ed.1 and ed. 2.

Robust

- Best-in class reliability based on 100+ years of experience in Sepam, MiCOM and Vamp relays
- Strong tests performed in international laboratories
- Compliant to IEC electro-mechanical standards
- Designed for demanding industrial conditions with conformal-coated printed circuit boards.

Efficient and connected

- Easy to order with 10 standard configurations delivered off the shelf in less than 7 days (location dependent)
- Easy to configure with the unique eSetup Easergy Pro setting software
- Easy to test with the virtual simulation test for direct injection of current and voltage from eSetup Easergy Pro
- Easy to install with withdrawable rear connectors with CT shortening
- Easy to use and maintain with the embedded web-HMI and EcoStruxure™ Power Device app for direct access on site via your laptop, smartphone, or tablet.



General characteristics

PowerLogic P3 Standard

PowerLogic P3 is designed to cover all the standard applications with only one device: the Universal Protection.

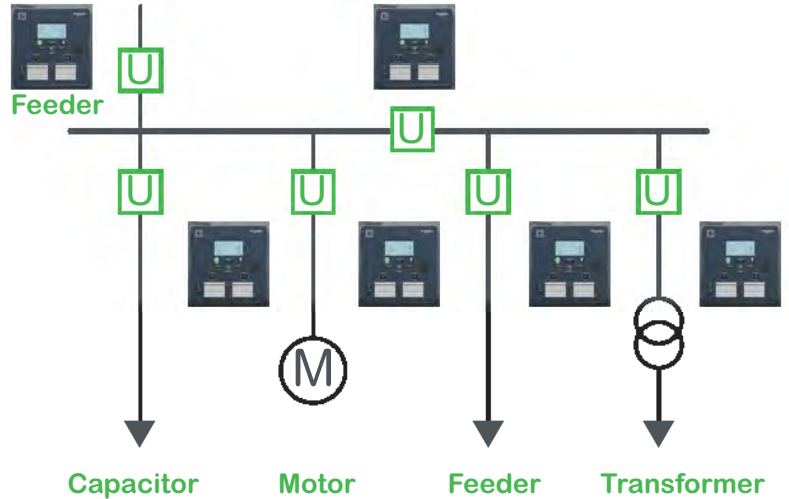

PowerLogic P3 Standard is available in 2 models:

Model	Communication	Main advantages
PowerLogic P3U20		
<ul style="list-style-type: none"> ■ 4 CT / 1VT ■ 10 DI / 5 DO / WD ■ 8 DI / 8 DO / WD 	Open communication protocols on serial or Ethernet links, with IEC 61850	Openness to IEC 61850 , while keeping the core functionalities of PowerLogic P3 Standard relay
PowerLogic P3U30		
<ul style="list-style-type: none"> ■ 4 CT / 4VT ■ 16 DI / 8 DO / WD ■ 14 DI / 11 DO / WD 	Open communication protocols on serial or Ethernet links, with IEC 61850	Wide scope of possibilities , with the directional protection, synchro-check, fault location, and increased number of input and outputs

A common set of functions extends the possibilities of protection and control:

- Single-line diagrams (mimic) in the display
- Programmable protection stages
- Programmable logics
- 2 programmable function keys
- Synchro-check function
- Direct-access USB port
- Up to 8 objects controlled.



General characteristics

PowerLogic P3 Advanced

The PowerLogic P3 advanced is a protection relay developed to satisfy the protection needs for buildings, distribution utilities, and industrial applications. Thanks to a wide scope of functionality and Ethernet communication, PowerLogic P3 advanced provides a cost-effective solution for the upper end of protection requirements in these applications.

Protect your staff and equipment and ensure safer operations with PowerLogic P3 Advanced's built-in arc flash detection and protection functions.

You will experience greater operational efficiency with rapid ordering, configuration, and operations for an unparalleled digital experience provided with PowerLogic P3.

PowerLogic P3 Advanced at a glance

Extended capabilities

- Extended protection functions, including differential of line, transformer, motor, and generator
- Arc flash detection
- All communication protocols embedded on serial and Ethernet links, including IEC 61850 ed.1 and ed. 2
- Increased number of inputs and outputs.

Robust

- Best-in class reliability based on 100+ years of experience in Sepam, MiCOM and Vamp relays
- Strong tests performed in international laboratories
- Compliant with IEC electro-mechanical standards.

Efficient and connected

- Easy to configure with the unique eSetup Easergy Pro setting software
- Easy to test with the virtual simulation test for direct injection of current and voltage from eSetup Easergy Pro
- Easy to use and maintain with the embedded web-HMI and EcoStruxure™ Power Device app for direct access on site via your laptop, smartphone, or tablet.



General characteristics PowerLogic P3 Advanced

PowerLogic P3 is designed to cover a large scope of applications.

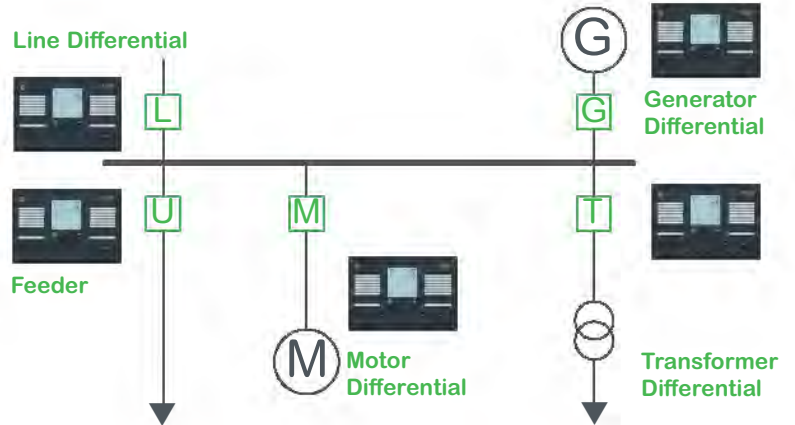

PowerLogic P3 Advanced is designed in **7 models, per application:**

Model	Function	
PowerLogic P3F		
30	Feeder	Protection
PowerLogic P3L		
30	Line	Line differential
PowerLogic P3M		
30	Motor	Protection
32	Motor	Differential
PowerLogic P3G		
30	Generator	Protection
32	Generator	Differential
PowerLogic P3T		
32	Transformer	Differential

A common set of functions extends the possibilities of protection and control:

- Single-line diagrams (mimic) in the display
- Programmable protection stages
- Programmable logics
- 2 programmable function keys
- Synchro-check function
- Direct-access USB port
- Up to 6 objects controlled
- Arc flash protection.



Learn more about PowerLogic P3 range here



Offer



Catalogue

Scan or click on QR code

If you need more details about product references and availability, please check your local Schneider Electric contact <https://www.se.com/ww/en/work/support/country-selector/contact-us.jsp>





PowerLogic P5

Network protection relays

The PowerLogic P5 at a glance

The PowerLogic P5 is a protection relay for demanding medium-voltage applications. It offers users industry-leading dedicated protection relay functionality to reduce risks, improve reliability, all with advanced connectivity. Additionally, it can be used with a range of digital tools that make everyday operations simpler for users. The PowerLogic P5 is part of the PowerLogic range of power monitoring and control solutions and has been built on more than 100 years of experience in protection relays, including Sepam, MiCOM, and Vamp ranges, renowned for their reliability and performance.

Industry-leading protection functions

- Built-in arc-flash protection function (optional)
- Nearby control with a mobile application
- Latest cybersecurity built in, certified according to IEC 62443 4-2 Security Level 1 and Achilles Level 2.

Best-in-class reliability

- Withdrawable design for quicker maintenance
- Backup memory function enabling industry-leading 10 minute recovery time!
- Condition monitoring for reduced risk of power outages and maximized equipment life
- Extended equipment lifetime when used with EcoStruxure Asset Advisor.

Maximized everyday simplicity

- Easier operation with digital tools including the EcoStruxure Power Device app
- Powerful communication with plug and play ports and seven protocols supported
- Scalable hardware making it easy to upgrade as your applications evolve.

Enjoy a package of sought-after features in one device



The PowerLogic P5 is a major step forward for protection relays, combining best-in-class features together in one device.

Built-in arc-flash protection functions

Arc-flashes will always exist when switching or during unexpected conditions.

If the protection function detects an arc-flash, it isolates the connected circuit breaker within milliseconds, preventing a growing arc-flash energy and thus an unexpected risk of outage.

Advanced cybersecurity

With its optional cybersecurity package the PowerLogic P5 is one of the first protection relays to be third-party certified according to IEC 62443 4-2 standard at Security Level 1. This means reduced exposure to cyber threats and improved operational security.

By default, the PowerLogic P5 includes important features such as password management, port hardening and secured communication compliant to the latest standards.

Intuitive withdrawable design

With a handle built in as part of the design, the P5 can be quickly disconnected or exchanged to speed up maintenance. Wiring, data, communication, and settings (including backup) can be stored with the panel and will be there when the relay is reconnected.

Improved recovery time

When maintenance or testing is required, PowerLogic P5 helps dramatically decrease your outage recovery time. The backup memory can automatically restore settings, you can continue your operations in as little as 10 minutes.^[*]

[*] Result of mean time to repair (MTTR) calculation conducted by Schneider Electric

Greater connectivity

The protection relay features seven communication protocols. This includes compliance with IEC 61850 Edition 1 and Edition 2, Modbus (serial/TCP), IEC 60870-5-103, IEC 60870-5-101, Ethernet/IP, and DNP3 (serial/TCP). PowerLogic P5 can support up to 3 Ethernet protocols simultaneously, including offering dual redundancy with PRP/HSR and RSTP protocols. Moreover, all communication modules can be added at any time, including on-site, during the product life cycle to allow you to upgrade your device in line with future network evolutions.



Make everyday operations easier with digital tools



The PowerLogic P5's industry leading protection features are complemented by a comprehensive set of tools available on mobile devices such as smartphones or tablets, and desktop computers. This means you get simpler installation, configuration, and maintenance, enabling you to save time and money. Nearby control and monitoring allows users to fully operate the device via wireless communication, from a safer distance.

Digital tools for the PowerLogic P5 include:

- **EcoStruxure Power Build** – Medium Voltage online ordering tool enables quicker and easier ordering
- **eSetup Easergy Pro** software with virtual injection testing
- Embedded web server, allowing easy and fast setting changes from a web browser
- **EcoStruxure™ Power Device app** for simpler and safer operation and maintenance
- **mySchneider app**, a simple way to access support and product data by flashing the QR code on the device.

As an EcoStruxure-ready solution, the PowerLogic P5's digital benefits can be taken even further with best-in-class monitoring of substation equipment health. For example, when paired with EcoStruxure Asset Advisor, users get data for predictive maintenance, which helps them reduce OpEx, speed up processes, and boost efficiency.

Take the PowerLogic P5 further with EcoStruxure™

EcoStruxure, Schneider Electric's IoT-enabled, open and interoperable architecture and platform, brings together Connected Products, Edge Control, and Apps, Analytics & Services. EcoStruxure connected products deliver enhanced value around safety, reliability, efficiency, sustainability, and connectivity.

450 000

EcoStruxure systems deployed since 2007 with the support of our 9,000 system integrators

EcoStruxure ready



Efficient asset management

Help boost your efficiency and participate to reduce downtime using predictive maintenance tools



24/7 connectivity

Make better informed decisions with real-time data that's available everywhere, anytime



Enhanced safety

Advanced features designed-in based on well-known designs, experience and technology

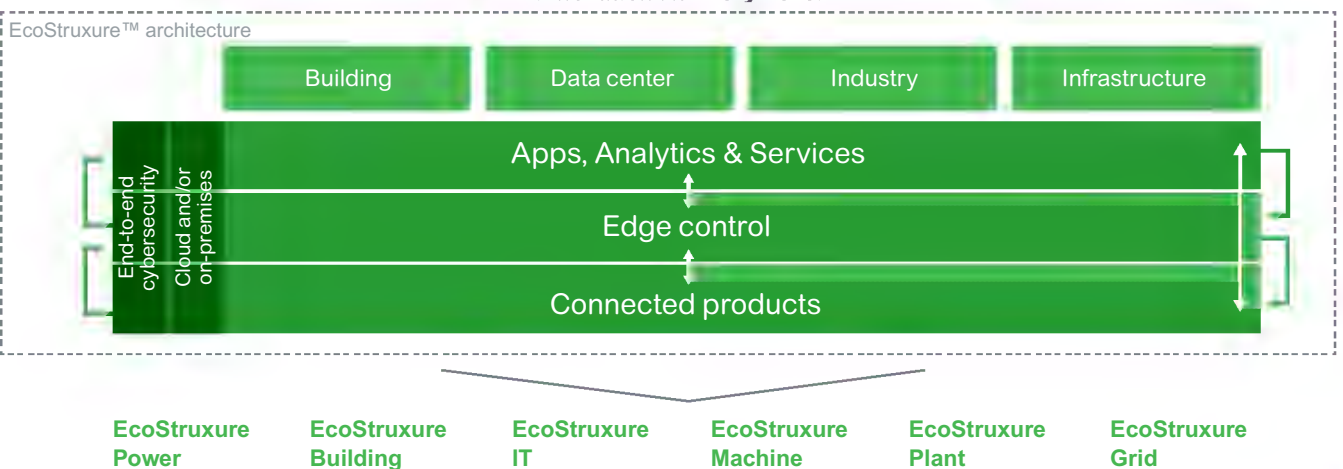

General characteristics

PowerLogic P5

A

PowerLogic P5 protection relay is based on proven technology concepts and developed in close cooperation with customers, so it's built to meet your toughest demands:

- Modular design that allows user-defined conventional protection and arc-flash protection solutions
- Compatible with conventional CTs/VTs or low power instrument transformers LPCT/LPVT compliant to IEC 61869-10 and IEC 61869-11
- Embeds latest cybersecurity functionality to help prevent intentional mis-use and cyber-threats
- Fast replacement with enhanced safety thanks to withdrawability and back-up memory that automatically restore parameters without using any configuration tools
- Advanced logic engine (option) supports the most complex automation & control schemes.

B

PowerLogic products are designed to be user friendly, a feature that is proven in our customer reports day after day. You'll benefit from features that include:

- A complete set of protection functions, related to the application
- Arc-flash detection in PowerLogic P5x30 models
- Dedicated circuit breaker control with single-line diagram, push buttons, programmable function keys, LEDs, and customizable alarms
- Multilingual HMI for customized messaging
- Settings tool relay management software for setting parameters, configuring, and network fault simulation
- Both serial and Ethernet communication, including redundancy
- IEC 61850 communication protocol including flexible product naming for smooth multi-vendor integration.

C

D

PowerLogic P5 is available in two sizes to best fit your needs:



PowerLogic P5x20



PowerLogic P5x30

PowerLogic P5 digital protection relays are designed for power distribution networks in:

- Utilities - Energy distribution.
- Large industrial processes:
 - Oil and Gas
 - Mining
 - Mineral and Metals
 - Water.
- Critical buildings and Industry:
 - Data Center
 - Healthcare
 - Transportation
 - Industrial buildings.

E

F

Range overview

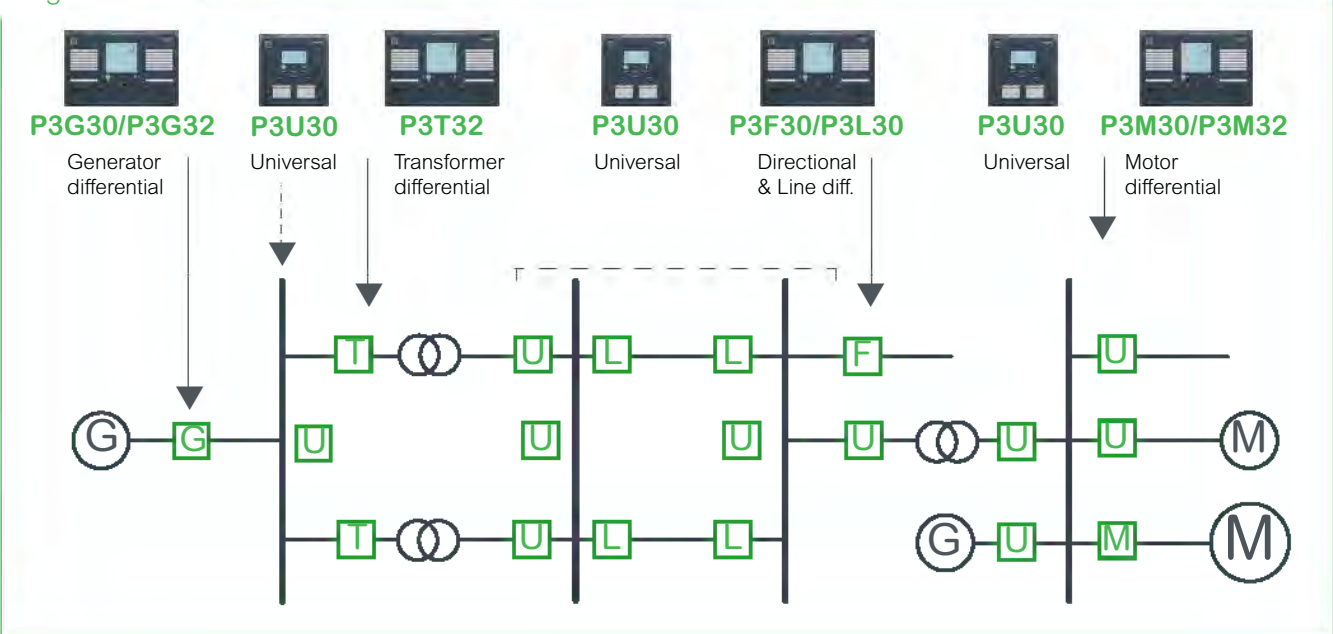

G

H

I

J

- A
- B
- C
- D
- E
- F
- G
- H
- I
- J



Learn more about
PowerLogic P5
range here



Offer



Catalogue

Scan or
click on
QR code

If you need more details about product references and availability, please check your local Schneider Electric contact <https://www.se.com/ww/en/work/support/country-selector/contact-us.jsp>

A

B

C

D

E

F

G

H

I

J



The PowerLogic™ P7 at a Glance

The PowerLogic™ P7 is a high-end protection and control device for most of your demanding protection applications.

It offers unparalleled flexibility and digital performance for industry-leading protection relay functionality to secure your power system, improve network reliability and asset condition monitoring, all with advanced and modular connectivity.

Part of the PowerLogic range of power monitoring and control solutions, PowerLogic P7 is built on more than 100 years of experience in protection relays, including Sepam, MiCOM, and Vamp ranges, renowned for their reliability and performance.



Operational Efficiency and Digital Experience

- Tailor and adapt to customer needs throughout device life cycle with a highly flexible, modular hardware and easy-to-expand application-oriented firmware
- Modular board design with plug and play concept enhances device maintenance and reduces installation downtime
- Compliance with IEC 61850 Ed. 2.1 provides more efficient delivery, engineering, operation and maintenance with seamless integration in power automation systems
- Stand-alone merging unit complying to IEC 61869-13, IEC 61869-9, IEC 61850-9-2LE
- Easily interact via the large and highly intuitive 7" color industrial touchscreen

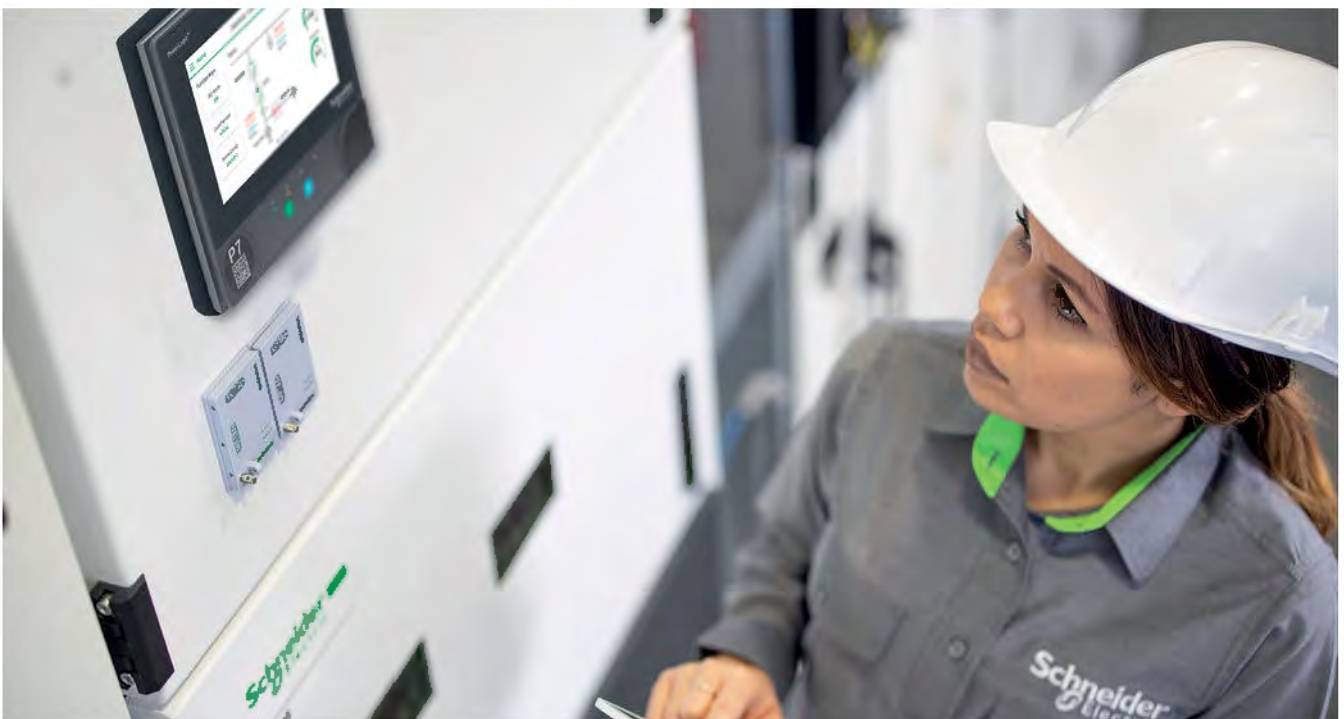

Electrical Safety and Security

- Enhanced maintenance safety with current transformer auto-shorting capability
- Reduce exposure to cyber threats with IEC62443 SL2 features
- Condition-monitoring allows targeted maintenance to maximize asset life
- Increased device robustness with IP54 front face and IK7 protected impact-strength design of the 7" touchscreen

Power Availability and Sustainability

- Avoid downtime with best-in-class, easily tailored protection applications
- Adapt to network evolutions with new flexible firmware application concept
- Future-ready, long-term solution built on more than 100 years of experience in protection relays
- Versatile operation range with a mission profile of -40 to 70 °C (-40 to 158 °F) and suitable for harsh environment

Enjoy a Package of Sought-After Features in One Device



The PowerLogic P7 presents a major step forward for protection relays, bringing several best-in-class features together in one device



Advanced Cybersecurity

IEC 62443 SL2, the PowerLogic P7 has been designed with a native cybersecurity package.

This means reduced exposure to cyber threats and improved operational security.

By default, the PowerLogic P7 includes important features such as firmware signature, secure boot, LDAP/Radius communication, password management, port hardening, and secured communication compliant to the latest international standards.

Modular, Flexible Design

Additional hardware like I/O cards, communication modules or accessories like RTD inputs or analogue I/O can be added at any time.

In addition, the flexible application concept allows you to customize the PowerLogic P7 to your needs at any time of the product life cycle.

Improved Recovery Time

When maintenance or testing is required, PowerLogic P7 significantly decreases outage time thanks to the intuitive HMI with clear and easily accessible device status information, plug & play boards, clear and simple slot numbering and removable wiring interfaces.

Greater Connectivity

The protection relay features multiple communication protocols. This includes IEC 61850 Edition 2.1, Modbus (serial/TCP), and DNP3 (serial/TCP). PowerLogic P7 can support up to 3 Ethernet protocols simultaneously, including offering redundancy with PRP/HSR and RSTP protocols.

Optional Ethernet communication modules (SFP*) can be added at any time, including on-site, during the product life cycle to allow you to upgrade your device in line with future network evolutions.

* SFP – Small Form-factor pluggable module

Comprehensive Digital Tools for Mobile, Tablet or Desktop

PowerLogic™ Engineering Suite Saves Time, Improves Efficiency

- PowerLogic Engineering Suite is an easy-to-use, versatile tool with functionalities and features needed throughout the life cycle of Schneider Electric protection and control IEDs, including support for seamless integration into EcoStruxure Power & Grid.
- One Tool Suite for all connected products offline/online
- Flexible and adaptable for multiple personas
- User-experience driven with built in contextual help
- Modern ergonomic design
- Future-proof, IEC 61850 compliant

Full Operation from a Safe Distance

Digital tools provide simpler installation, configuration, and maintenance, enabling smoother operations, saving both time and money. Digital tools include:

- **PowerLogic Engineering Suite** with our next generation of tools, for device and system architecture configuration, engineering and maintenance
- **mySchneider app** allows to access product information and documentation in a very simple way, just by flashing the QR code on the device
- **Product Selector tool** helps the user during the selection and configuration steps to choose the right set of product options/features, according to the needs



As an EcoStruxure-ready solution, the PowerLogic P7's digital benefits can be taken even further with best-in-class monitoring of substation equipment health. For example, when paired with **EcoStruxure Asset Advisor**, users get data for predictive maintenance, which helps them reduce OpEx, speed up processes, and boost efficiency.



Take the PowerLogic P7 further with EcoStruxure™

EcoStruxure, Schneider Electric's IoT-enabled, open and interoperable architecture and platform, brings together Connected Products, Edge Control, and Apps, Analytics & Services. EcoStruxure connected products deliver enhanced value around safety, reliability, efficiency, sustainability, and connectivity.

More than
450 000

EcoStruxure systems deployed since 2007 with the support of our 9,000 system integrators

EcoStruxure ready



Efficient asset management

Help boost your efficiency and participate to reduce downtime using predictive maintenance tools



24/7 connectivity

Make better informed decisions with real-time data that's available everywhere, anytime



Enhanced safety

Advanced features designed-in based on well-known designs, experience and technology

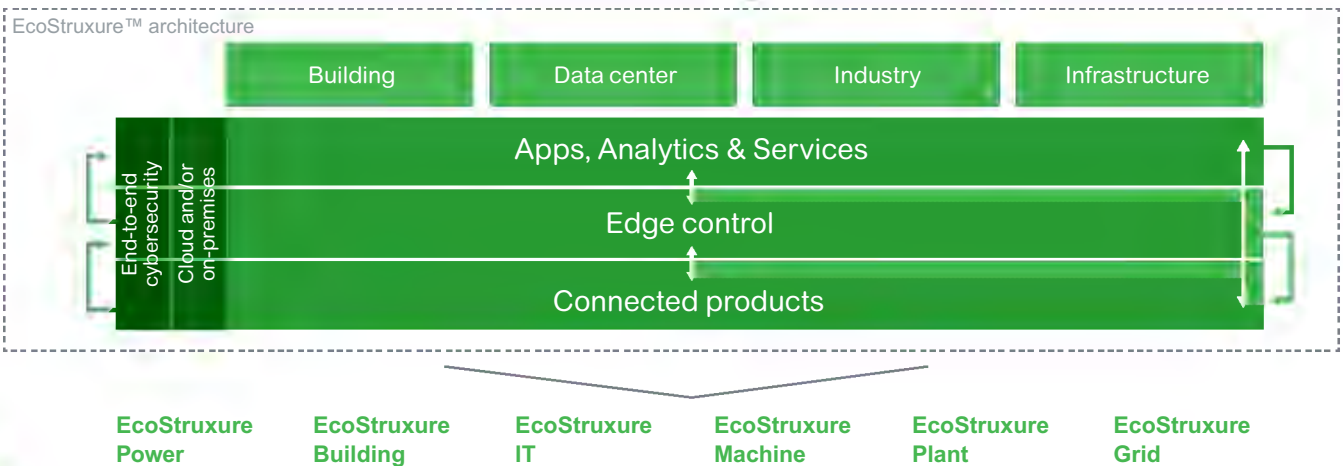

PowerLogic™ P7 protection and control devices are based on state-of-the-art technology concepts and developed in close cooperation with customers, so it's built to meet your toughest demands:

- Flexible and modular design that allows the user to adapt the hardware to their needs.
- Embeds latest cybersecurity functionality to help prevent intentional misuse and cyber-threats.
- Fast and simple maintenance thanks to modularity and standardized boards and modules.

PowerLogic™ products are designed to be user friendly, a feature that is proven in our customer reports day after day. You'll benefit from features that include:

- A complete set of flexible, configurable protection and control functions related to the application.
- Switchgear control with tailorable single-line diagram, programmable function keys, LEDs, and customizable alarms.
- 7" touchscreen with intuitive navigation concept.
- Easy-to-use Engineering tool for setting parameters, device configuration, and network fault analysis.
- Both serial and Ethernet communication, including Ethernet redundancy with RSTP/HSR/PRP/failover support.
- Efficient engineering thanks to IEC 61850 Edition 2.1.



PowerLogic P7

PowerLogic™ P7 high-end protection and control devices are designed for electrical power systems in:

- Power & Grid:
 - Transmission Utilities
 - Distribution Utilities
 - Distributed Energy Resources
 - Wind/Solar Farm
- Energy & Chemicals:
 - Oil and Gas
 - Mining
 - Mineral and Metals
- Critical Infrastructure:
 - Data Center
 - Transportation

Range Overview

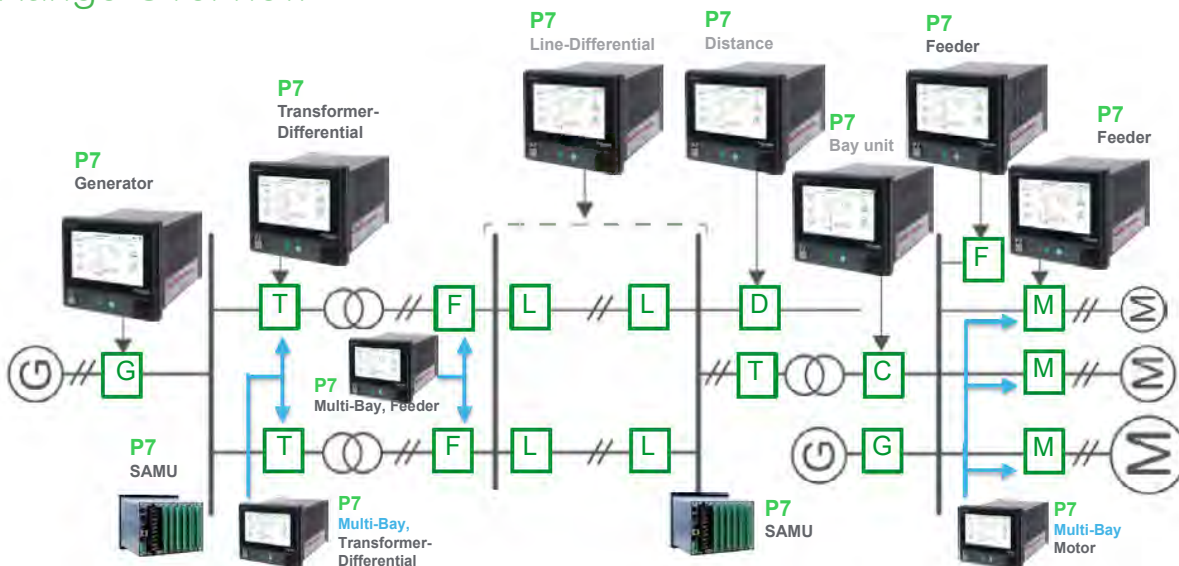

Range overview shows future application scope



Learn more about
PowerLogic P7
range here



Scan or
click on
QR code

Offer

If you need more details about product references and availability, please check your local Schneider Electric contact <https://www.se.com/ww/en/work/support/country-selector/contact-us.jsp>



PowerLogic A1 and A3

- A
- B
- C
- D
- E
- F
- G
- H
- I
- J



PowerLogic™ A1 and A3

Arc Flash Mitigation devices

PowerLogic A1 and A3 are designed to mitigate the Arc fault inside electrical cubicles. That will reduce the Arc flash damages and impacts.

Arc flash fault is an electrical phenomenon that occurs when electricity passes through an air gap between two conductors. This develops an arc of electrical current resulting in a powerful release of energy, usually in the form of heat, light, and sound. The arc flash fault can be caused by many factors, which includes improper installation, loose or corroded connections, or a fault in the electrical system. That can be very dangerous, as it releases tremendous amount of energy quickly.



PowerLogic™ A1 and A3 are designed to adapt to small to medium size installation. The mechanical design, installation possibilities, simple wiring, and adapted configuration modes make the PowerLogic™ A1 and A3 to adapt to different users during the life cycle of this range.

Secured and Fast Connection



PowerLogic™ A1 and A3 are designed to simplify all the steps of the product life cycle.

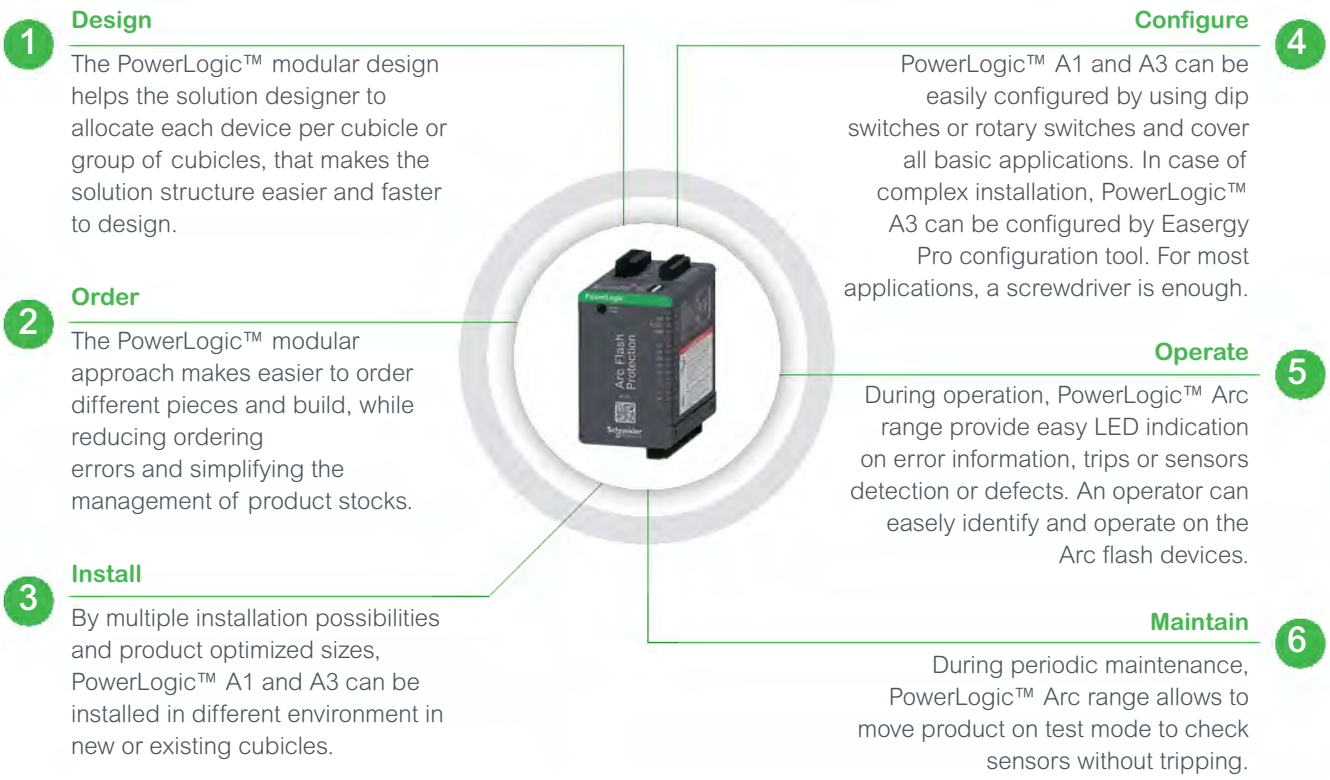

- A
- B
- C
- D
- E
- F
- G
- H
- I
- J

PowerLogic A1 and A3

Smart Design for Easy Installation

- Arc flash protection is required for both LV and MV cubicle. Cubicle constructions are different depends on voltage levels, electrical distribution structure, national standards, and habits. It makes installation constraints different for each cubicle.
- The Arc flash protection could be installed in newly constructed panels or undated panels in existing cubicles in case of retrofit. In retrofit, electrical panels are generally fulfilled with other equipment and in this case, a newly added device should be compact to fit inside available rooms.
- PowerLogic™ A1 and A3 range provide several installation possibilities. All devices can be fixed on back DIN rail mounting. With a total depth of 120 mm, devices could be installed easily in LV panels.
- If the panel depth is lower, PowerLogic™ Arc devices could be installed with on the side DIN rail mounting. That makes the depth 70 mm for A125 or A3-F devices, and 35 mm for A3-S devices. The modification of the DIN rail mounting fixation from back to side is easy and fast.
- Flush mounting accessories are designed to allow a robust and secured front panel mounting of PowerLogic™ A1 and A3 devices.
- In all mounting positions, devices LEDs are visually accessible.
- For faster and secured installation, product wiring is easier to pluggable connector.

Mechanical Mounting

Three Mounting modes for easy mounting in green field and brown field application



- **DIN Rail Back Mounting:** for dept cubicle like in MV



- **DIN Rail Side Mounting:** for limited depth cubicle like in LV



- **DIN Rail Flush Mounting:** to get product access of the cubicle front

The PowerLogic™ Arc range can be deployed in a single MV cubicle where three sensors can secure the arc protection up to medium size application with numbers of MV switchgears or LV switchboards.





The connection flexibility and the easy logic built for common protection schematics, makes this range accessible and easy to use for more applications.

Selecting the right device becomes simple and helps to avoid any error.

The PowerLogic™ Arc range for small to medium size applications is composed by:

- **PowerLogic™ A1:** stand-alone device for cubicle protection.
- **PowerLogic™ A3:** can be used as stand-alone device or associated to other A3 devices and build a system solution. PowerLogic™ A3 devices could be connected through a high-speed bus to perform high performance protection at system construction.

Selection guide

PowerLogic™ Arc	A125	A3-F6P	A3-F12P	A3-S6P	A3-S12P
					
Number of Light sensors	4	6	12	6	12
Trip outputs	2	3	2	1	0
Watchdog trip	1	0	1	0	
Operation mode	Stand Alone	System Main unit		Extension Modules to A3-F	
Power supply	Yes	Yes	Yes	-	-
POE (Power Over Ethernet)	-	Yes	Yes	Yes	Yes
Dimensions (mm / in)	70.6 x 134.4 x 126.2 / 2.78 x 5.29 x 4.97			34 x 134.4 x 125.1 / 1.34 x 5.29 x 4.92	

General characteristics

PowerLogic A1 and A3

PowerLogic™ A125 Functions

We can supply an arc flash protection system tailored to your application

PowerLogic™ A125 at a glance

- **Dedicated unit for each bay**
VAMP 125 Arc flash protection units are versatile and independently operating devices for bay based protection.
- **Designed for partners**
They offer optimized and cost effective solutions for panel builders and OEMs.
- **Hardware**
 - Interface for four Arc flash sensors
 - Two output relays: One relay output, one high speed output
 - One change-over output for self-supervision
 - Wide range auxiliary power supply
 - External inputs for remote control
 - External input for current criteria



An arc flash protection unit is a protective device used to enhance the environment of your installation.

User benefits

- **Suitable product**
Fit to various customer segments like utilities, commercial and industrial buildings, mining, steel, cement, other industry and OEMs.
- **Easy to integrate**
 - QR code for product identification and documentation
 - Simple configuration and commissioning
- **Easy to use**
 - Easy entry to arc flash protection
 - One variant with wide-range power supply
 - Optimized for standard switchgear configurations

Example of application

One or two incomers and several outgoing feeders

The following applications are typically used for arc flash protection in MV power distribution in commercial buildings and light industries. The arc flash protection is commercialized using A125 arc flash protection units, VA1-DA type point sensors and appropriate wiring between the units.

Operation

Incomer cubicle has three sensors. Activation of sensor S1 operates T1 output. The arc fault happen in the CB compartment sensor S3 activates and controls upstream CB via T2 output. Equally, if the arc fault happens in the power transformer bushings, an upstream CB is tripped through T2.

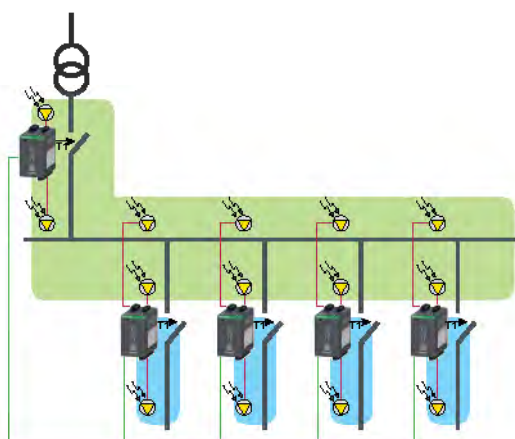

General characteristics PowerLogic A1 and A3 PowerLogic™ A3 Functions



An arc flash protection units A3-F6P and A3-S12P are protective devices.

User benefits

- **Compact product**
Easy fits in MV and LV cubicles. Provides easy configuration modes for faster installation in most applications Multiple cubicle protection capability
- **Easy to integrate**
 - QR code for product identification and documentation access
 - With few references cover multiple application modes
- **Easy to use**
 - Easy product selection
 - Dual power supply: Auxiliary and POE*
 - Optimized for common electrical MV and LV cubicles
 - Easy multi-devices commissioning

(*) Power Over Ethernet between devices and limited to two devices.

Versatile device to several application

PowerLogic A3 can be used on standalone mode to control one or two circuit breakers and larger cubicles thanks to high number of sensors supported. It can also be used in simple system mode, it means associated with other PowerLogic A3.

Many operation modes are possible:

- Without selectivity: any sensor will make tripping all trip outputs.
- With selectivity: make tripping the circuit breaker related to the zone of the sensor. That makes the faulty zone separated from other circuits.

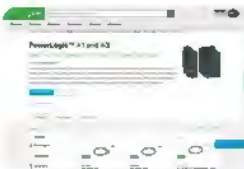

Learn more about PowerLogic A1 and A3 range here



Offer



Technical brochure

Scan or click on QR code

If you need more details about product references and availability, please check your local Schneider Electric contact <https://www.se.com/ww/en/work/support/country-selector/contact-us.jsp>





A

B

C

D

E

PowerLogic T300

Substation Controller

F

The PowerLogic T300 at a glance

The PowerLogic T300 tackle electrical distribution network and distribution automation challenges with this smart grid-ready remote terminal unit (RTU). PowerLogic T300 is a remote terminal unit configurable to your precise specifications. PowerLogic T300 delivers advanced monitoring, protection, control, and automation functions in both overhead and underground electrical distribution networks. The PowerLogic T300 is part of the PowerLogic range of power monitoring and control solutions and has been built on more than 100 years of experience in remote terminal units including T200 and Saitel ranges, renowned for their reliability and performance.

G

Industry-leading remote terminal unit

- Compact and modular Automation RTU
- Powerful platform, scalable to answer your needs
- Advanced monitoring, protection, control, and automation functions
- Nearby monitoring and control with a mobile application
- Latest cybersecurity built in, certified according to IEC 62443-4-2 Security Level Capability 1, and designed according to a Secure Development lifecycle certified as per IEC 62443-4-1.

H

Best-in-class reliability

- Withdrawable modules for quicker maintenance
- Backup power supply with full battery management to operate the substation during the power outage
- Condition monitoring for reduced risk of power outages and maximized equipment life

I

J

Maximized everyday simplicity

- Easier operation with digital tools including embedded Web server with Wi-Fi connectivity for easing commissioning, exploitation and maintenance
- Powerful communication with plug and play ports and main industrial protocols supported
- Scalable hardware making it easy to upgrade.

The PowerLogic T300 is the RTU to answer your evolving challenges and prepare your business for the future.



Developed as per IEC 62443-4-2, PowerLogic™ T300 has been designed with a cyber security package. This shall help reduce exposure to cyber threats and improved operational security. It includes important features such as password management, firmware signature, port hardening, and secured communication compliant to the latest international standards.

Evolve with the grid: manage bidirectional and intermittent power flow

- Detect overcurrent faults including grid with interconnected distributed energy resource units
- Detect broken conductors and voltage loss

Increase availability: improve SAIDI and optimize MV and LV networks

- Detect medium-voltage (MV) faults by current and voltage measurements to reduce outage time
- Reconfigure the network automatically after a MV fault (in centralized, semi centralized or decentralized approaches)
- Reduce low-voltage (LV) outage durations by blown fuse detection

Maintain quality: deliver MV and LV stability

- Accommodate demand growth
- Measure MV and LV voltage accurately for Volt-Var optimization
- Detect neutral cut out at transformer level

Manage costs: reduce installation, operation, and maintenance expenditures

- Optimize investment with modular automation solutions
- Enable remote and local operation and asset management including firmware and configuration update
- Save cost on spare parts, training, and operation of personnel by using a single platform for multiple applications
- Substation asset management based on thermal and environmental monitoring

Deliver efficiency: optimize networks to manage growing consumption

- Monitor transformers and substations to optimize asset management
- Reduce both technical and non-technical losses
- Manage load shedding and peak shaving

Improve Cybersecurity: help defend against malicious software and unauthorized access

- As per IEC 62443, IEC 62351 and IEEE 1686
- SCADA communication and Wi-Fi Access security features



General overview

PowerLogic™ T300

Make everyday operations easier with digital tools

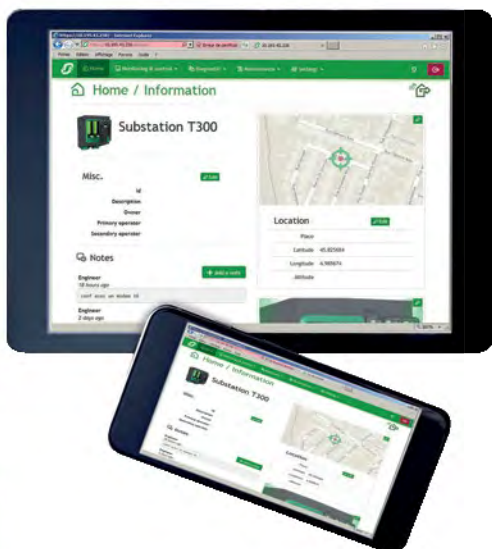

Digital tools for the PowerLogic T300 include:

- Three configuration tools are available with T300:
 - T300 Web Server: Dedicated to the end user for the operation, commissioning, exploitation and maintenance, this tool allows (according to the Cybersecurity access and roles)
 - Easergy Builder: Advanced Engineering tool for experts, this tool enables adding/modifying the configuration of the T300 application:
 - T300 Generator: User friendly tool to generate standard T300 configuration file. The file generated can be downloaded directly to T300 using Web server interface or imported into Easergy Builder for deeper customization.
- An embedded Web Server as HMI interface and local supervision of the substation for the user. Basic configuration, operation and diagnosis are carried out by connecting a laptop, tablet or smartphone to the T300 Web Server.
- Operation and control: Alongside operation and control of the network from the SCADA system, it is possible to operate the equipment locally or remotely using data pages.
- mySchneider app, a simple way to access support and product data by flashing the QR code on the device.
- EcoStruxure System Management (eSM) allows to track the evolution of all the configuration & software artifacts throughout the lifecycle.
 - Device Management
 - Baseline Management: Backup Configuration and track
 - Mass Firmware & Configuration Update.

Point name	Description	Value	Quality	Leading
HEXI_LL40_C7Health_spl01_Fail	Head unit configuration error	0 (N° Normal)	OK	OK
HEXI_LL40_EVHealth_spl01_Fail	Head unit error	1 (OK Fault)	OK	OK
HEXI_LL40_HVHealth_spl01_Fail	General health error	1 (OK Fault)	OK	OK
HEXI_LL40_PHealth_spl01_Fail	General health warning	0 (N° Normal)	OK	OK
HEXI_LL40_CommHealth_spl01_Fail	Internal communication fault	0 (N° Normal)	OK	OK
HEXI_GandGAP1_Health_spl01_Fail	PLC warning	0 (N° Normal)	OK	OK
HEXI_GandGAP1_Health_spl01_Fail	PLC error	0 (N° Normal)	OK	OK
HEXI_LL401_TimeSync1_spl01_Fail	Time synchronization failure source 1	1 (OK Fault)	OK	OK
HEXI_LL402_TimeSync2_spl01_Fail	Time synchronization failure source 2	0 (N° Normal)	OK	OK
HEXI_VIPRECCH1_Chk_spl01_Fail	VPI on/off status	0 (OFF)	OK	OK

Take the PowerLogic T300 further with EcoStruxure™

500 000

EcoStruxure™ has been deployed in almost 500 000 sites with the support of 20 000+ developers, 650 000 service providers and partners, 3 000 utilities, and connects over 2 million assets under management.

EcoStruxure™ ready



Efficient asset management

Greater efficiency with **predictive** maintenance helping to reduce downtime



24/7 connectivity

Real-time data **everywhere anytime** to make better-informed decisions



Increased safety

Proven design and experience combined with fast **embedded arc detection** to enhance people's safety and equipment's protection

EcoStruxure™ is our open, interoperable, IoT-enabled system architecture and platform. EcoStruxure delivers enhanced value around **safety, reliability, efficiency, sustainability, and connectivity** for our customers. EcoStruxure leverages advancements in IoT, mobility, sensing, cloud, analytics, and cybersecurity to deliver Innovation at Every Level. This includes Connected Products, Edge Control, and Apps, Analytics & Services which are supported by Customer Lifecycle Software.

Turn data into action

EcoStruxure™ architecture lets customers maximize the value of data. Specifically, it helps them:

- Translate data into actionable intelligence and better business decisions
- Take informed decisions to secure uptime and operational efficiency thanks to real-time control platforms
- Gain visibility to their electrical distribution by measuring, collecting, aggregating, and communicating data

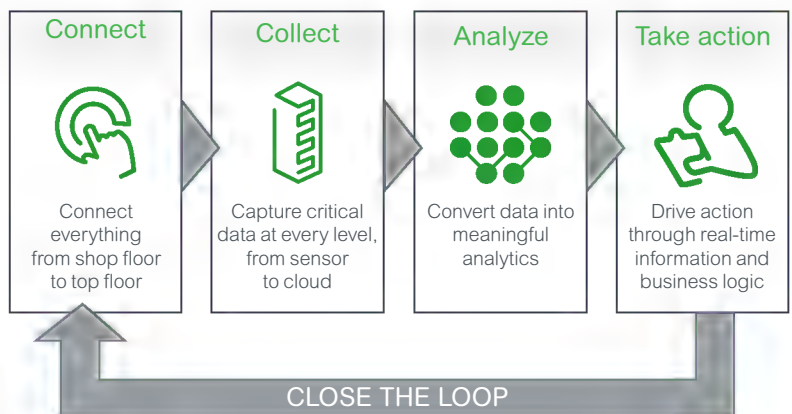

EcoStruxure™
Innovation At Every Level

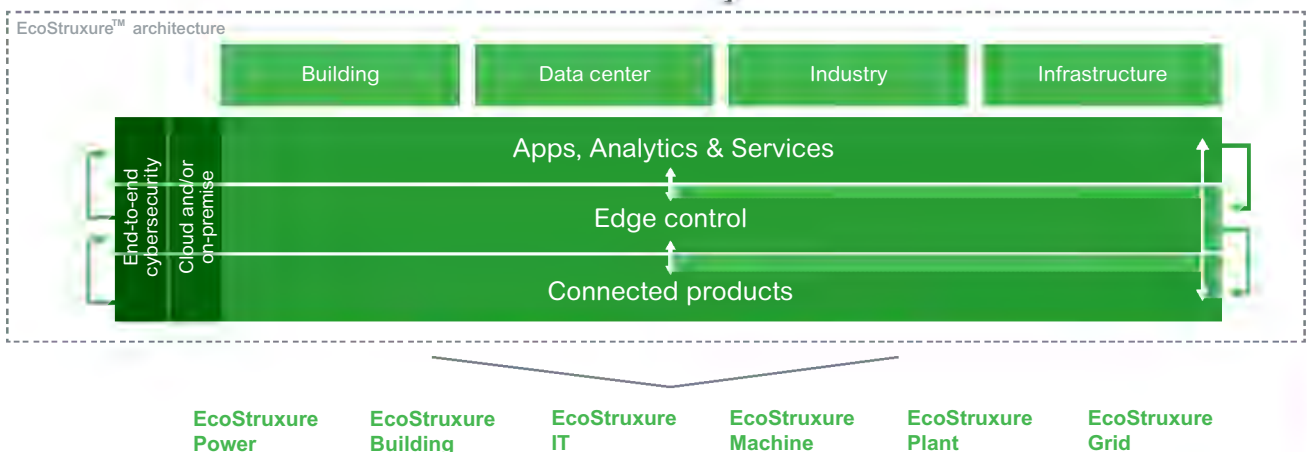

General characteristics

PowerLogic™ T300

Operating an electrical distribution grid is an increasingly complex business. The challenges posed by growing demand, integration of distributed generation resources, and aging infrastructure – to name just a few – each affect overall grid reliability and customer satisfaction.

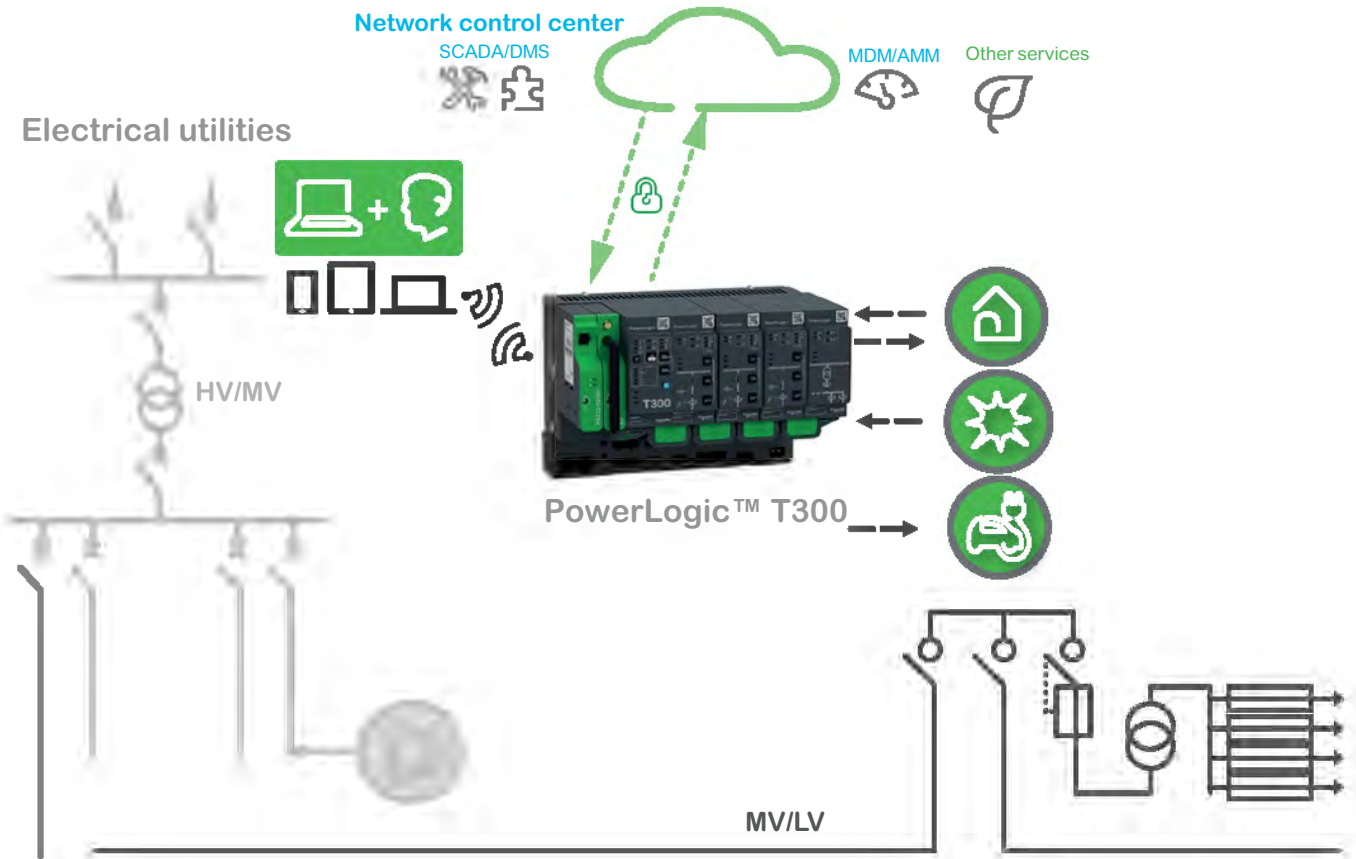

PowerLogic™ T300 keys grid control applications use:

- Centralized grid control as MV substation controller and power monitor
- Decentralized automation network reconfiguration such as sectionalized or Auto Transfer Source
- Decentralized network reconfiguration with self healing applications
- Reduce outage time and network losses
- Improve Volt var management
- Improve fault management
- Improve power quality
- Cut down maintenance costs
- Optimize investments
- Compliance with latest polices and standards such as cyber security and IEC 61850.



Learn more about
PowerLogic
T300



Offer



Catalogue

Scan or
click on
QR code



If you need more details about product references and availability, please check your local Schneider Electric contact <https://www.se.com/ww/en/work/support/country-selector/contact-us.jsp>



DISTRITAMA PERKASA

Life Is On

Schneider
Electric

PT Distritama Perkasa
Authorized Distributor Schneider Electric di Indonesia

Head Office & Distribution Center

Komplek Arcadia Blok G6 No.5-6
Jl Daan Mogot Km 21 Tangerang 15122
Telp: +6221 29006316

MV Distribution Centre

Komplek Arcadia Blok G6 No. 1
Jl Daan Mogot Km 21 Tangerang 15122
Telp: +6221 29006316

Branch Office East Indonesia

Sinarmas Land Plaza 12 A Floor
Jl. Pemuda No 60 - 70
Surabaya 60271